

INSTRUCTION MANUAL

DIGITAL STORAGE OSCILLOSCOPE DCS-9700 SERIES

DCS-9730	DCS-9730D
DCS-9720	DCS-9720D
DCS-9710	DCS-9710D
DCS-9707	DCS-9707D



■ **About a trademark, a registered trademark**

A company name and the brand name mentioned in this instruction manual are the trademark or the registered trademark of each company or group in each country and region.

■ **About this instruction manual**

When copying the part or all of contents of this instruction manual, seek the copyright holder.

In addition, the specifications of the product and the contents of this instruction manual are subject to change without notice for improvement. Please check to our website for the latest version.

■ **About export**

When export or ship the product to overseas, please confirm laws and regulations about the export.

Table of Contents

USING THE PRODUCT SAFELY.....	I - V
1. GETTING STARTED.....	1
1-1. Main Features	1
1-2. Accessories.....	3
1-3. Panel Overview	4
1-3-1. Front Panel.....	4
1-3-2. Rear Panel	10
1-3-3. Display.....	12
1-4. Set Up	14
1-4-1. Tilt Stand	14
1-4-2. Module Installation	15
1-4-3. Software Installation	16
1-4-4. Power Up.....	16
1-4-5. First Time Use	17
1-4-6. How to Use This Manual	19
2. QUICK REFERENCE	24
2-1. Menu Tree / Operation Shortcuts	24
2-1-1. Convention	24
2-1-2. Acquire Key.....	25
2-1-3. Acquire Key – Segments	25
2-1-4. Autoset Key.....	26
2-1-5. CH1 ~ 4 Key.....	26
2-1-6. Cursor Key	26
2-1-7. Display Key	27
2-1-8. Help Key.....	27
2-1-9. Math Key	28
2-1-10. Measure Key	29
2-1-11. Hardcopy Key.....	30
2-1-12. Run/Stop Key	30
2-1-13. REF Key	30
2-1-14. Save/Recall Key	31
2-1-15. Test Key	32
2-1-16. Test Key – Go-NoGo	32
2-1-17. Trigger Type Menu	33
2-1-18. Trigger Edge Menu.....	33
2-1-19. Trigger Delay Menu	33
2-1-20. Trigger Pulse Width Menu	34
2-1-21. Trigger Video Menu	34
2-1-22. Trigger Pulse Runt Menu.....	34
2-1-23. Trigger Rise & Fall Menu	35
2-1-24. Trigger Timeout Menu	35
2-1-25. Utility Key	36
2-1-26. Utility Key – I/O.....	37
2-1-27. Utility Key – File Utilities	37
2-1-28. Utility Key – Wave Generator - Demo Outputs	38
2-1-29. Search - Edge	38

2-1-30. Search – Pulse Width	39
2-1-31. Search - Runt	39
2-1-32. Search – Rise/Fall Time	40
2-1-33. Zoom Key	40
2-1-34. Option Key.....	41
2-2. Default Settings	42
2-3. Built-in Help	43
3. MEASUREMENT	44
3-1. Basic Measurement	44
3-1-1. Channel Activation	44
3-1-2. Autoset	45
3-1-3. Run/Stop	46
3-1-4. Horizontal Position/Scale.....	47
3-1-5. Vertical Position/Scale.....	48
3-2. Automatic Measurement	49
3-2-1. Measurement Items.....	49
3-2-2. Add Measurement	53
3-2-3. Remove Measurement	54
3-2-4. Gated mode.....	54
3-2-5. Display All mode.....	55
3-2-6. High Low Function.....	56
3-2-7. Statistics	57
3-3. Cursor Measurement	59
3-3-1. Use Horizontal Cursors	59
3-3-2. Use Vertical Cursors	61
3-4. Math Operation.....	64
3-4-1. Overview	64
3-4-2. Addition/Subtraction/Multiplication/Division	65
3-4-3. FFT.....	66
3-4-4. Advanced Math	68
3-4-5. Edit F(x).....	69
4. CONFIGURATION	70
4-1. Acquisition	70
4-1-1. Select Acquisition Mode	70
4-1-2. Digital Filter	71
4-1-3. Show Waveform in XY Mode.....	72
4-1-4. Set the Sampling Mode	74
4-1-5. Set the Record Length.....	75
4-2. Segmented Memory Acquisition	76
4-2-1. Segments Display	76
4-2-2. Set the Number of Segments	76
4-2-3. Run Segmented Memory.....	77
4-2-4. Navigate Segmented Memory	78
4-2-5. Segment Measurement	78
4-2-6. Display All.....	79
4-2-7. Automatic Measurement.....	80
4-2-8. Segment Info	82
4-3. Display.....	82

4-3-1. Display Waveform as Dots or Vectors	82
4-3-2. Set the Level of Persistence	83
4-3-3. Set the Intensity Level	83
4-3-4. Set the Waveform Intensity Type	84
4-3-5. Select Display Graticule	85
4-3-6. Freeze the Waveform (Run/Stop).....	85
4-3-7. Turn Off Menu	86
4-4. Horizontal View	87
4-4-1. Move Waveform Position Horizontally	87
4-4-2. Select Horizontal Scale	87
4-4-3. Select Waveform Update Mode.....	88
4-4-4. Zoom Waveform Horizontally	89
4-5. Vertical View (Channel).....	91
4-5-1. Move Waveform Position Vertically	91
4-5-2. Select Vertical Scale	91
4-5-3. Select Coupling Mode	91
4-5-4. Input Impedance.....	92
4-5-5. Invert Waveform Vertically.....	92
4-5-6. Limit Bandwidth	93
4-5-7. Expand by Ground/Center.....	93
4-5-8. Select Probe Type.....	94
4-5-9. Select Probe Attenuation Level	94
4-5-10. Set the Deskew	95
4-6. Trigger	95
4-6-1. Trigger Type Overview	95
4-6-2. Trigger Parameter Overview	97
4-6-3. Setup Holdoff Level.....	100
4-6-4. Setup Trigger Mode.....	101
4-6-5. Using the Edge Trigger.....	101
4-6-6. Using Advanced Delay Trigger.....	102
4-6-7. Using Pulse Width (glitch) Trigger.....	103
4-6-8. Using Video Trigger.....	104
4-6-9. Pulse Runt trigger.....	105
4-6-10. Using Rise and Fall (slope) Trigger.....	106
4-6-11. Using the Timeout Trigger.....	107
4-7. Search	108
4-7-1. Configuring Search Events.....	108
4-7-2. Copying Search Event To/From Trigger Events	109
4-7-3. Search Event Navigation.....	110
4-7-4. Save Search Marks	110
4-7-5. Setting/Clearing Single Search Events.....	111
4-7-6. Play / Pause	111
4-8. System Info / Language / Clock	113
4-8-1. Select Menu Language.....	113
4-8-2. View System Information.....	113
4-8-3. Erase Memory	114
4-8-4. Turn the Buzzer On/Off	115
4-8-5. Set Date and Time	115

4-8-6. Demo Outputs	116
5. OPTIONAL SOFTWARE and APPS	118
5-1. Applications	118
5-1-1. Overview	118
5-1-2. Running Applications.....	118
5-1-3. Uninstalling Applications.....	118
5-1-4. Using Go-NoGo.....	119
5-2. Optional Software	123
5-2-1. Activating Optional Software	123
5-2-2. Running Optional Software.....	123
5-2-3. Uninstalling Optional Software	124
6. SAVE/RECALL	125
6-1. File Format/Utility	125
6-1-1. Image File Format	125
6-1-2. Waveform File Format	125
6-1-3. Spreadsheet File Format.....	125
6-1-4. Setup File Format.....	128
6-2. Create/Edit Labels	129
6-3. Save	131
6-3-1. File Type/Source/Destination	131
6-3-2. Save Image	132
6-3-3. Save Waveform.....	133
6-3-4. Save Setup.....	134
6-4. Recall	135
6-4-1. File Type/Source/Destination	135
6-4-2. Recall Default Panel Setting.....	136
6-4-3. Recall Waveform.....	137
6-4-4. Recall Setup.....	138
6-5. Reference Waveforms.....	139
6-5-1. Recall and Display Reference Waveforms	139
7. FILE UTILITIES	141
7-1. File Navigation	141
7-2. Create Folder	143
7-3. Rename File.....	144
7-4. Delete File	145
7-5. Copy File to USB	145
8. HARDCOPY KEY	147
8-1. Printer I/O Configuration	147
8-2. Print Output.....	148
8-3. Save - Hardcopy Key	148
9. REMOTE CONTROL CONFIG	150
9-1. Configure USB Interface	150
9-2. Configure RS-232C Interface	151
9-3. Configure the Ethernet Interface.....	152
9-4. Configure Socket Server	154
9-5. Configure GP-IB	155
9-6. USB/RS-232C Functionality Check	156
9-7. Socket Server Functionality Check	157

9-8. GP-IB Functionality Check	159
9-9. Web Server Overview	161
10. MAINTENANCE	163
10-1. How to use SPC function.....	163
10-2. Vertical Accuracy Calibration	164
10-3. Probe Compensation.....	165
11. APPENDIX	167
11-1. DCS-9700 Specifications	167
11-1-1. Model-specific	167
11-1-2. Common-specific.....	167
11-2. Probe Specifications	171
11-2-1. GTP-070B-4	171
11-2-2. GTP-150A-2	171
11-2-3. GTP-250A-2	172
11-2-4. GTP-350A-2	172
11-3. DCS-9700 Dimensions	173
11-4. FAQ.....	174



USING THE PRODUCT SAFELY

■ **Preface**

To use the product safely, read this instruction manual to the end. Before using this product, understand how to correctly use it. If you read this manual but you do not understand how to use it, please ask us or your local dealer. After you read this manual, save it so that you can read it, anytime as required.

■ **Pictorial indication**

This instruction manual and product show the warning and caution items required to safely use the product. The following pictorial indication and warning character indication are provided.

<Pictorial indication>	
	<p>Some part of this product or the instruction manual may shows this pictorial indication. In this case, if the product is incorrectly used in that part, a serious danger may be brought about on the user's body or the product. To use the part with this pictorial indication, be sure to refer to this instruction manual.</p>
 	<p>If you use the product, ignoring this indication, you may get killed or seriously injured. This indication shows that the warning item to avoid the danger is provided.</p> <p>If you incorrectly use the product, ignoring this indication, you may get slightly injured or the product may be damaged. This indication shows that the caution item to avoid the danger is provided.</p>

Please be informed that we are not responsible for any damages to the user or to the third person, arising from malfunctions or other failures due to wrong use of the product or incorrect operation, except such responsibility for damages as required by law.

USING THE PRODUCT SAFELY



- **Do not remove the product's covers and panels**

Never remove the product's covers and panels for any purpose. Otherwise, the user's electric shock or fire may be incurred.
- **Warning on using the product**

Warning items given below are to avoid danger to user's body and life and avoid the damage or deterioration of the product.
Use the product, observing the following warning and caution items.
- **Warning items on power supply**
 - Power supply voltage

The rated power supply voltages of the product are 100, 120, 220 and 240VAC. The rated power supply voltage for each product should be confirmed by reading the label attached on the back of the product or by the "rated" column shown in this instruction manual. The specification of power cord attached to the products is rated to 125VAC for all products which are designed to be used in the areas where commercial power supply voltage is not higher than 125VAC. Accordingly, you must change the power cord if you want to use the product at the power supply voltage higher than 125VAC. If you use the product without changing power cord to 250VAC rated one, electric shock or fire may be caused.

When you used the product equipped with power supply voltage switching system, please refer to the corresponding chapter in the instruction manuals of each product.
 - Power cord
(Important) The attached power cord set can be used for this device only.

If the attached power cord is damaged, stop using the product and call us or your local dealer. If the power cord is used without the damage being removed, an electric shock or fire may be caused.
 - Protective fuse

If an input protective fuse is blown, the product does not operate. For a product with external fuse holder, the fuse may be replaced. As for how to replace the fuse, refer to the corresponding chapter in this instruction manual.

If no fuse replacement procedures are indicated, the user is not permitted to replace it. In such case, keep the case closed and consult us or your local dealer. If the fuse is incorrectly replaced, a fire may occur.

USING THE PRODUCT SAFELY

■ **Warning item on Grounding**

If the product has the GND terminal on the front or rear panel surface, be sure to ground the product to safely use it.

■ **Warnings on Installation environment**

- **Operating temperature and humidity**
Use the product within the operating temperature indicated in the “rating” temperature column. If the product is used with the vents of the product blocked or in high ambient temperatures, a fire may occur. Use the product within the operating humidity indicated in the “rating” humidity column. Watch out for condensation by a sharp humidity change such as transfer to a room with a different humidity. Also, do not operate the product with wet hands. Otherwise, an electric shock or fire may occur.
- **Use in gas**
Use in and around a place where an inflammable or explosive gas or steam is generated or stored may result in an explosion and fire. Do not operate the product in such an environment.
Also, use in and around a place where a corrosive gas is generated or spreading causes a serious damage to the product. Do not operate the product in such an environment.
- **Installation place**
Avoid installing the product on inclined places or on places subject to vibration. Otherwise, the product may slip or fall down to cause damages or injury accidents.

■ **Do not let foreign matter in**

Do not insert metal and inflammable materials into the product from its vent and spill water on it. Otherwise, electric shock or fire may occur.

■ **Warning item on abnormality while in use**

In abnormal situations, such as “smoke”, “fire”, “abnormal smell” or “irregular noise” occur from the product while in use, stop using the product, turn off the switch, and remove the power cord plug from the outlet. After confirming that no other devices catch fire, ask us or your local dealer.

USING THE PRODUCT SAFELY

■ Warning Item for the Measurement

- When you measure a part of a high voltage, be careful not to touch a hand to a measurement part directly. There is a risk of an electric shock.
 - Be sure to connect the probe or the cable and the ground side of the input connector to the ground potential (ground) of the substance measured. Since the chassis of this instrument is connected to the ground of the input block, connecting the earth lead of the probe to the potential floating from the ground potential may result in the following:
 - Electric shock
 - A high current flows and damages the substance measured, this instrument, and other connected device.
- The following parts are connected to the chassis:
- Probe for each channel and ground side of the input BNC connector
 - Grounding conductor of the accessory 3-core power cord
 - Ground pin for an interface signal

“Bad example”

Prohibition

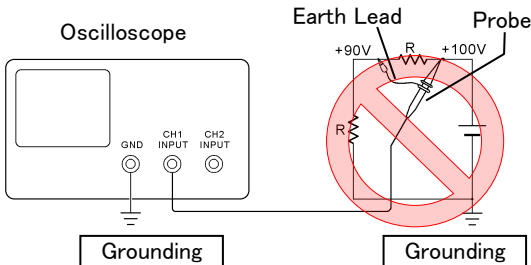

At connecting as Bad Example, +90V and chassis are shorted, and damages substance a measured. Therefore do not make such connection.

If the instrument is not grounded, a potential of the chassis is +90V. Ground a chassis, in order to prevent an electric shock accident.

When measuring the floating potential, a differential method of measurement is recommended (refer to the figure below).

“Good example”

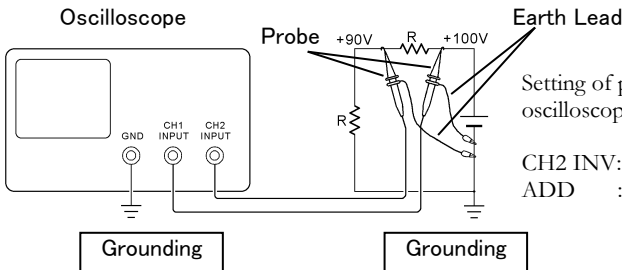

Setting of panel switches of an oscilloscope

CH2 INV: ON (CH2 inverted)
ADD : ON (CH1+CH2)

USING THE PRODUCT SAFELY

■ **Input / Output terminals**

Maximum input to terminal is specified to prevent the product from being damaged. Do not supply input, exceeding the specifications that are indicated in the "Rating" column in the instruction manual of the product.

Also, do not supply power to the output terminals from the outside.

Otherwise, a product failure is caused.

■ **Calibration**

Although the performance and specifications of the product are checked under strict quality control during shipment from the factory, they may be deviated more or less by deterioration of parts due to their aging or others.

It is recommended to periodically calibrate the product so that it is used with its performance and specifications stable.

For consultation about the product calibration, ask us or your local dealer.

■ **Daily Maintenance**

When you clean off the dirt of the product covers, panels, and knobs, avoid solvents such as thinner and benzene. Otherwise, the paint may peel off or resin surface may be affected.

To wipe off the covers, panels, and knobs, use a soft cloth with neutral detergent in it. During cleaning, be careful that water, detergent, or other foreign matters do not get into the product.

If a liquid or metal gets into the product, an electric shock and fire are caused. During cleaning, remove the power cord plug from the outlet.

Use the product correctly and safely, observing the above warning and caution items. Because the instruction manual indicates caution items even in individual items, observe those caution items to correctly use the product.

If you have questions or comments about the instruction manual, ask us or E-Mail us.

1. GETTING STARTED

The Getting started chapter introduces the oscilloscope's main features, appearance, and set up procedure.



1-1. Main Features

Model name	Frequency bandwidth	Input channels	Real-time Sampling Rate
DCS-9707	70MHz	4	2GSa/s
DCS-9710	100MHz	4	2GSa/s
DCS-9720	200MHz	4	2GSa/s
DCS-9730	300MHz	4	2GSa/s
DCS-9707D	70MHz	2	2GSa/s
DCS-9710D	100MHz	2	2GSa/s
DCS-9720D	200MHz	2	2GSa/s
DCS-9730D	300MHz	2	2GSa/s



Note

This instruction manual has been described as the 4ch model. In 2ch model, Can't set the ch3 and ch4.

Features

- 8 inch TFT SVGA display.
- All models feature a real-time sampling rate of 2GSa/s and an equivalent time sampling rate of 100GSa/s.
- Deep memory: 2M points record length.
- Waveform capture rate of 80,000 waveforms per second.
- Vertical sensitivity: 1mV/div~10V/div.
- Logic Analyzer module (optional): Adds 8 or 16 channel digital inputs and serial bus (I²C, SPI, UART) and parallel bus triggering.
- DDS Function Generator module (optional).
- Segmented Memory: Optimizes the acquisition memory to selectively capture only the important signal details. Up to 2048 successive waveform segments can be captured with a time-tag resolution of 8ns. Segmented memory can be used for both analog and digital channels.
- Enhanced Search: Allows the scope to search for a number of different signal events.
- On-screen Help.
- 64 MB internal flash disk.

Interface

- USB host port: front and rear panel, for storage devices.
- USB device port: rear panel, for remote control or printing.
- Demo output
- GP-IB (optional)
- RS-232C port.
- Calibration output
- SVGA output and Ethernet port (optional)

1-2. Accessories

Standard Accessories	Part number	Description
Power cord	N/A	region dependent
Passive probe	GTP-070B-4	70MHz(DCS-9707 / DCS-9707D)
	GTP-150B-4	150MHz(DCS-9710 / DCS-9710D)
	GTP-250A-2	250MHz(DCS-9720 / DCS-9720D)
	GTP-350A-2	350MHz(DCS-9730 / DCS-9730D)

Options	Option Number	Description
	DS2-LAN	Ethernet & SVGA output
	DS2-GPIB	GP-IB Interface
	DS2-FGN	DDS Function Generator
	DS2-08LA	8-Channel Logic Analyzer card with 8-Channel Logic Analyzer Probe (GTL-08LA)
	DS2-16LA	16-Channel Logic Analyzer card with 16-Channel Logic Analyzer Probe (GTL-16A)

Optional Accessories	Part number	Description
	GTL-110	Test lead, BNC to BNC heads
	GTL-232	RS-232C cable, 9-pin Female to 9-pin Female, Null modem for PC
	GTL-246	USB cable USB2.0A-B type cable
	GTL-08LA	8Ch Logic Analyzer Testing Probe
	GTL-16LA	16Ch Logic Analyzer Testing Probe

Drivers		
	USB driver	for Windows PC
	LabVIEW driver	

1-3. Panel Overview

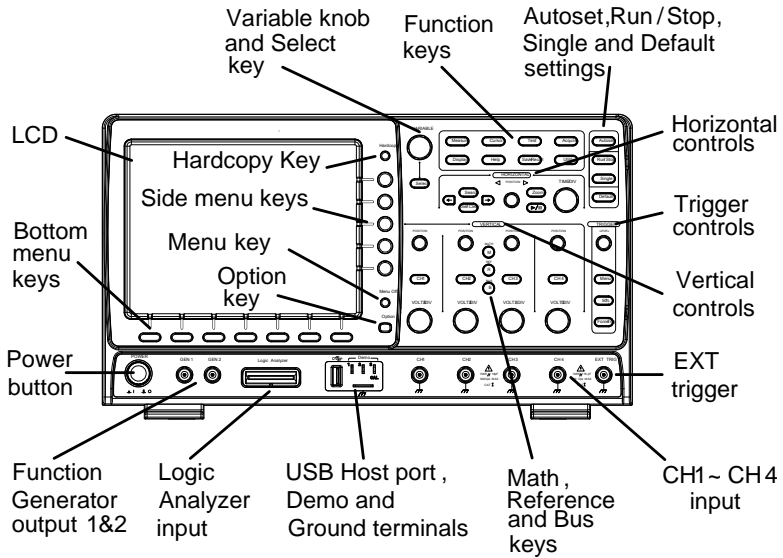

1-3-1. Front Panel

4ch Model

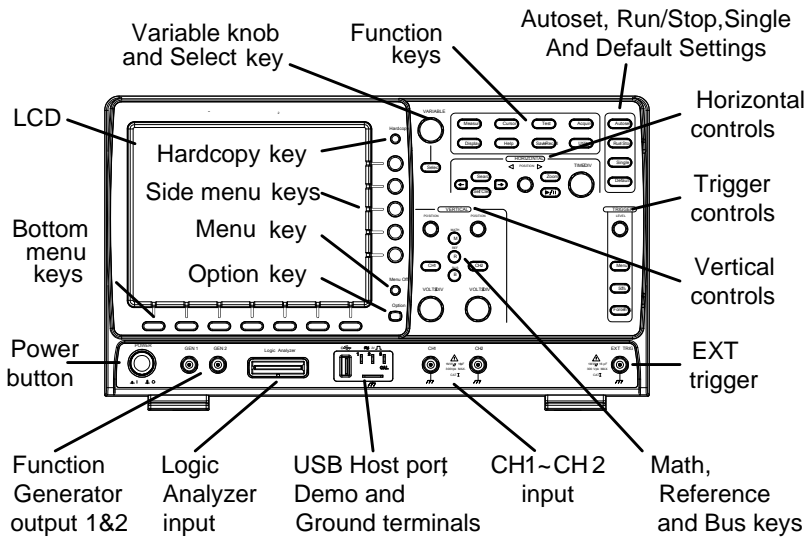

2ch Model





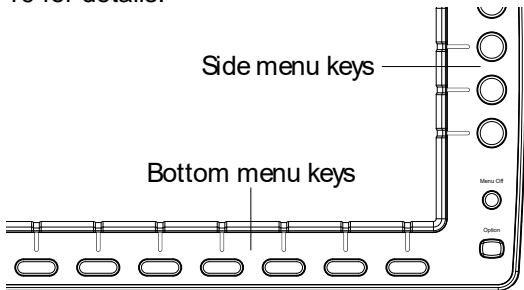

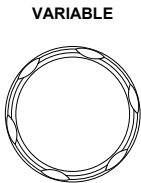
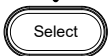



- LCD Display** 8" SVGA TFT color LCD. 800 x 600 resolution, wide angle view display.
- Menu Off Key**  Use the Menu Off key to hide the onscreen menu system.
- Option Key**  The Option key is used to access any installed options, such as the Logic Analyzer option.
- Menu Keys**  The Side menu and Bottom menu keys are used to make selections from the soft-menus on the LCD user interface. To choose menu items, use the 7 Bottom menu keys located on the bottom of the display panel. To select a variable or option from a menu, use the Side menu keys on the side of the panel. See page 19 for details.

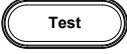

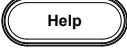
- Hardcopy Key**  The Hardcopy key is a quick-save or quick-print key, depending on its configuration. For more information see pages 148(save) or 148(print).
- Variable Knob and Select Key**  The Variable knob is used to increase/decrease values or to move between parameters.  The Select key is used to make selections.

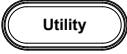
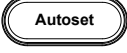
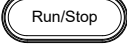
Function Keys The Function keys are used to enter and configure different functions on the DCS-9700 .

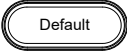
Measure		Configures and runs automatic measurements.
Cursor		Configures and runs cursor measurements.
Test		Configures and runs applications.
Acquire		Configures the acquisition mode, including Segmented Memory acquisition.
Display		Configures the display settings.
Help		Shows the Help menu.
Save/Recall		Used to save and recall waveforms, images, panel settings.
Utility		Configures the Hardcopy key, display time, language, calibration and Demo outputs. It also accesses the file utilities menu.
Autoset		Press the Autoset key to automatically set the trigger, horizontal scale and vertical scale.
Run/Stop Key		Press to Freeze (Stop) or continue (Run) signal acquisition (page 46). The run stop key is also used to run or stop Segmented Memory acquisition (page 77).
Single		Sets the acquisition mode to single triggering mode.
Default Setup		Resets the oscilloscope to the default settings.

Horizontal Controls The horizontal controls are used to change the position of the cursor, set the time base settings, zoom into the waveforms and search for events*.

Horizontal Position ◀ POSITION ▶ The Position knob is used to position the waveforms horizontally on the display screen.



TIME/DIV
Knob



The Time/Div knob is used to change the horizontal scale.

Zoom

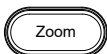

Press Zoom in combination with the horizontal Position knob.

Play/Pause



The Play/Pause key allows you to view each search event in succession – to effectively “play” through each search event.

Search



The Search key accesses the search function menu to set the search type, source and threshold.

Search Arrows



Use the arrow keys to navigate the search events.

Set/Clear

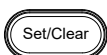

Use the Set/Clear key to set or clear points of interest when using the search function.

Trigger Controls The trigger controls are used to control the trigger level and options.

Level Knob

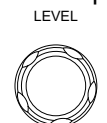

Used to set the trigger level.

Trigger Menu
Key
50% Key

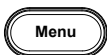

Used to bring up the trigger menu.

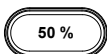

Sets the trigger level to the half way point (50%).

Force - Trig

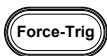

Press to force an immediate trigger of the waveform.

Vertical
POSITION

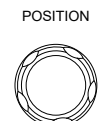

Sets the vertical position of the waveform.

Channel Menu
Key



Press the CH1~4 key to set and configure the channel.

VOLTS/DIV
Knob

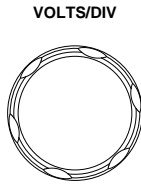

Sets the vertical scale of the channel.

External Trigger
Input

EXT TRIG



Accepts external trigger signals (page 95).

Input impedance: $1M\Omega$

Voltage input: $\pm 15V(\text{peak})$, EXT trigger capacitance: $16pF$.

Math Key



Use the math key to set and configure math functions.

Reference Key



Press the Reference key to set or remove reference waveforms.

BUS Key



The Bus key is used for parallel and serial bus (UART, I²C and SPI) configuration. Serial bus and parallel bus functionality is included with the Logic Analyzer options (DS2-08LA/DS2-16LA).

Channel Inputs

CH1



Accepts input signals.
Input impedance: $1M\Omega$.

USB Host Port



TypeA, 1.1/2.0 compatible. Used for data transfer.

Ground Terminal



Accepts the DUT ground lead for common ground.

Demo and
Probe
Compensation
Outputs

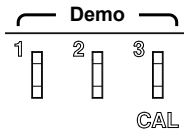

The Demo outputs are multifunction outputs that can be configured for probe compensation, as a trigger output or as a basic waveform generator for demonstration purposes. (FM signal, UART, I²C, SPI).

By default, the 3 Demo outputs are configured as:

- 1: Trigger output
- 2: FM waveform
- 3: Probe Compensation signal CAL (Demo 3) outputs a 2Vp-p, square wave signal for probe compensation.

Please see page 116 for details.

Logic Analyzer
Port

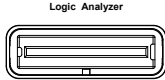

The Logic Analyzer port is used to connect to a Logic Analyzer probe. This port only functions if the optional logic analyzer module is installed.

Function
Generator
Output

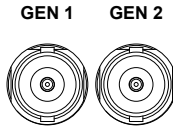

The function generator outputs are used with an optional function generator module.

Power Switch

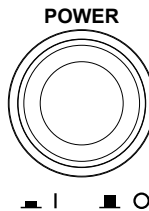

Used to turn the power on/off.

- | : ON
- ○ : OFF

1-3-2. Rear Panel

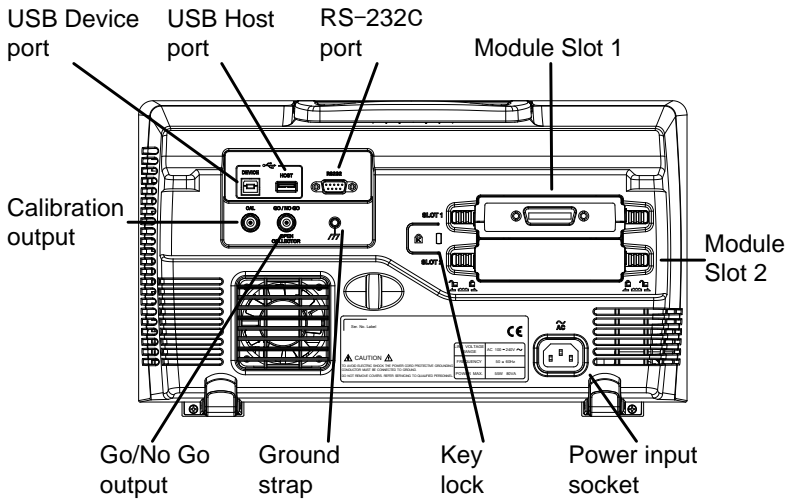

Calibration Output

CAL

Outputs the signal for vertical scale accuracy calibration (page 164).



USB Device Port

DEVICE

The USB Device port is used for remote control.

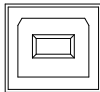

USB Host Port

HOST

The USB Host port is used to data transfer.



Note: Only one rear panel USB port can be used at a time. Inserting a USB flash drive into the USB Host Port will disable the USB Device Port.

RS-232C Port

RS232

Used for RS-232C-based remote control.

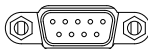

Module Slots

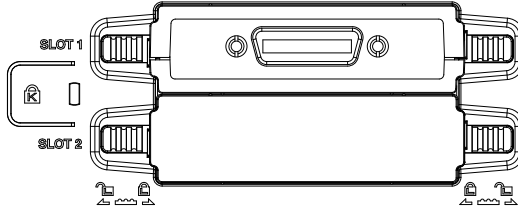

The module slots are used to install the optional modules:

DS2-LAN : Ethernet and SVGA
 DS2-GPIB : GP-IB
 DS2-08LA : 8 channel logic analyzer
 DS2-16LA : 16 channel logic analyzer
 DS2-FGN :Function generator

Power Input Socket

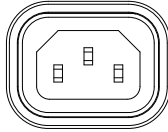

Power cord socket accepts AC mains, 100 ~ 240V, 50/60Hz. For power up sequence, see page 16.

Security Slot



Kensington security slot compatible.

Ground Strap Connector



For use with a grounding strap.

Go-No Go Output

GO / NO GO

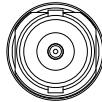





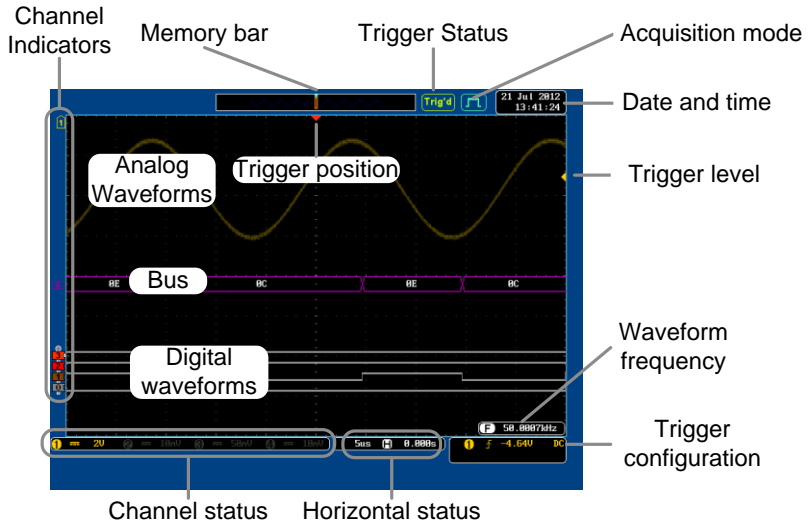

Outputs Go-No Go test results (page 119) as a 500us pulse signal.

OPEN COLLECTOR

1-3-3. Display

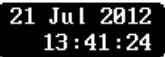

Analog Waveforms	Shows the analog input signal waveforms. Channel 1: Yellow Channel 2: Blue Channel 3: Pink Channel 4: Green
Bus Waveforms	Shows the bus waveforms for either parallel or serial buses. The values are displayed in hex or binary.
Digital Waveforms	Shows the digital channel waveforms. There can be up to 16 digital channels.
Channel Indicators	The channel indicators show the zero volt level of the signal waveform for each activated channel. Any active channel is shown with a solid color.  Analog channel indicator  Bus indicator(B)  Digital channel indicator  Reference waveform indicator  Math indicator
Trigger Position	Shows the position of the trigger.
Horizontal Status	Shows the horizontal scale and position.
Date and Time	 Current date and time (page 115).
Trigger Level	 Shows the trigger level on the graticule.

Memory Bar

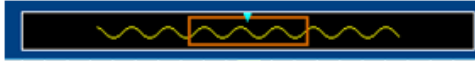

The ratio and the position of the displayed waveform compared with the internal memory (page 87). Triggered.

Trigger Status

Trig'd

PrTrig

Trig?

Stop

Roll

Auto

Pre-trigger.

Not triggered, display not updated.

Trigger stopped. Also appears in Run/Stop (page 46).

Roll mode.

Auto trigger mode.

For trigger details, see page 95.

Acquisition Mode



Normal mode



Peak detect mode



Average mode

For acquisition details, see page 70.

Signal Frequency

F 60.9033Hz

Shows the trigger source frequency.

F <2Hz

Indicates the frequency is less than 2Hz (lower frequency limit).

Trigger Configuration Horizontal Status

1 f -4.64V DC

Trigger source, slope, voltage, coupling.

5us H 0.000s

Horizontal scale, horizontal position.

For trigger details, see page 95.

Channel Status

1 == 2V

Channel 1, DC coupling, 2V/Div.

For channel details, see page 91.

1-4. Set Up
1-4-1. Tilt Stand

Tilt

To tilt, pull the legs forward, as shown below.

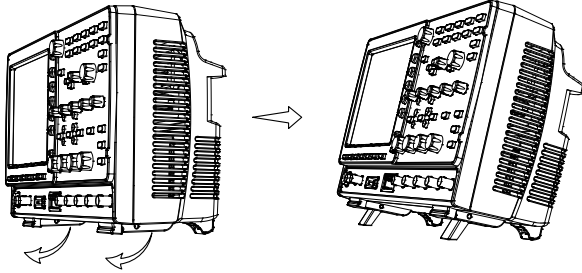

Stand

To stand the scope upright, push the legs back under the casing as shown below.

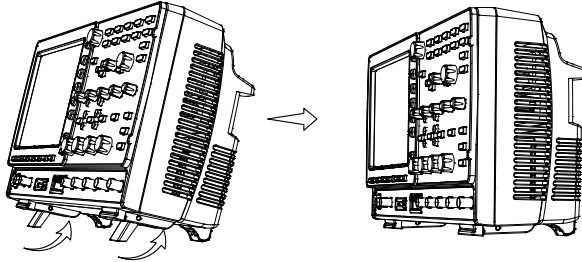

1-4-2. Module Installation

Background The DCS-9700 has a number of optional modules that can be installed into the module slots on the rear panel. These modules must be installed before power up.

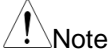

Note

The modules are not hot-swappable. Please ensure the power is off before connecting or disconnecting any of the modules from the rear panel.

Steps

1. Make sure the power is turned off before installing any of the optional modules.
2. Slide the tabs holding the module cover to the unlock position and then remove

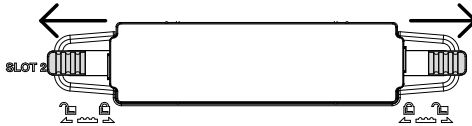

3. Install the optional module. Be sure to make sure that the grooves on the module line-up to the slots in the module bay.

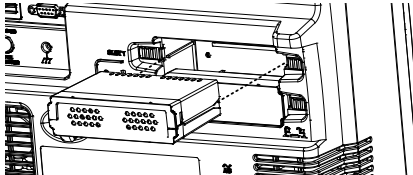

4. Slide the tabs back into the lock position.

1-4-3. Software Installation

Background The DCS-9700 has optional software packages to expand the functionality of the standard DCS-9700. An activation key is required to activate any optional software. A different activation key is required for each optional software package. For the latest files and information regarding the optional software packages, see our website or contact your nearest distributor.

Steps 1. Install any hardware modules if needed. See page 15 for installation details.

Panel Operation 2. Insert the USB serial key for the desired option into the front panel USB A port.

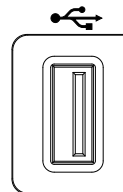

3. Press the *Utility* key then the *File Utilities* soft-key.

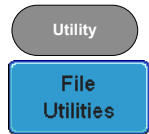

VARIABLE

4. Navigate to the desired file in the USB file path.

When the desired installation file has been found, press the *Select* key to start the installation.

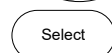
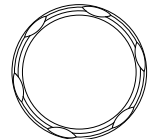

5. The installation will complete in a few seconds. When finished a pop-up message will appear asking you to restart the DCS-9700.



6. Restart the DCS-9700.

1-4-4. Power Up

Requirements The DCS-9700 accepts line voltages of 100 ~ 240V at 50 or 60Hz.

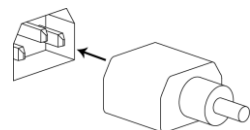
Step 1. Connect the power cord to the rear panel socket.



2. Press the POWER key.
The display becomes active in ~ 30 seconds.
-  : ON
 : OFF

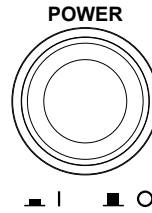

Note

The DCS-9700 recovers the state right before the power is turned OFF. The default settings can be recovered by pressing the Default key on the front panel. For details, see page 136.

1-4-5. First Time Use

Background	This section describes how to connect a signal, adjust the scale, and compensate the probe. Before operating the DCS-9700 in a new environment, run these steps to make sure the instrument performs at its full potential.	
1. Power On	Follow the procedures on the previous page.	
2. Set the Date and Time	Set the date and time.	Page 115
3. Reset System	Reset the system by recalling the factory settings. Press the <i>Default</i> key on the front panel. For details, see page 136.	
4. Install Optional modules	There are a number of optional hardware modules that can be installed, such as the optional function generator.	Page 15
5. Install Optional Software	Optional software packages may also need to be installed.	Page 16
6. Connect Probe	Connect the probe to the Channel 1 input and to the CAL signal output (Demo 3 output). This output provides a 2Vp-p, 1kHz square wave for signal compensation by default. Set the probe attenuation to x10 if the probe has adjustable attenuation.	

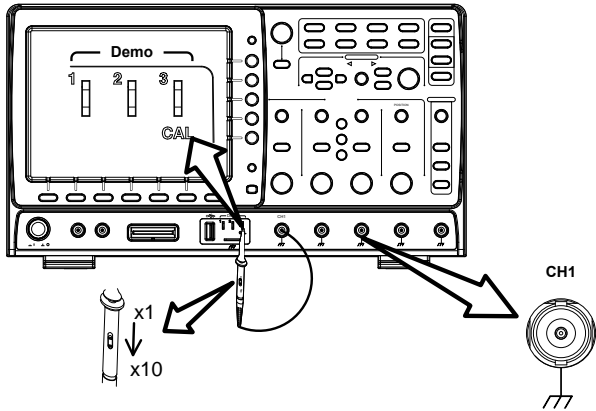

6. Capture Signal (Autoset)

Press the *Autoset* key. A square waveform appears on the center of the screen. For Autoset details, see page 45.

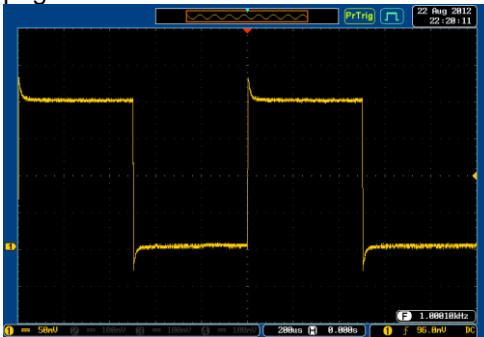

7. Select Vector Waveform

Press the *Display* key, and set the display to *Vector* on the bottom menu.

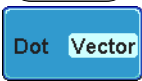
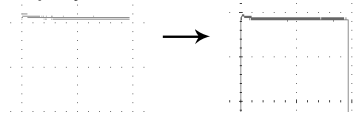
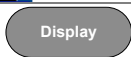

8. Compensate Probe Turn the adjustment point on the probe to make the square waveform edge flat.

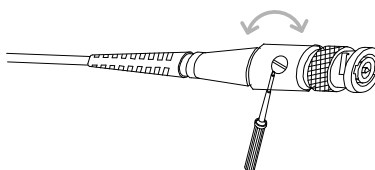
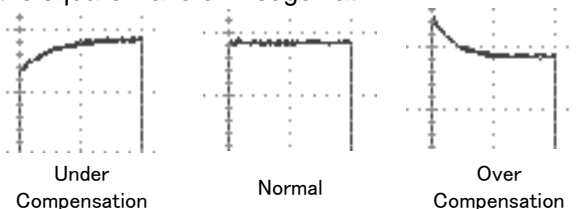

9. Start Operation Continue with the other operations.
Measurement: page 44 Configuration: page 70
Save/Recall: page 125 File Utilities: page 141
Apps.: page 118 Hardcopy key: page 147
Remote Control: page 150 Maintenance: page 163

1-4-6. How to Use This Manual

Background This section describes the conventions used in this manual to operate the DCS-9700. Throughout the manual any reference to pressing a menu key refers to the keys directly below or beside any menu icons or parameters. When the user manual says to “toggle” a value or parameter, press the corresponding menu item. Pressing the item will toggle the value or parameter. Active parameters are highlighted for each menu item. For example in the example below, Coupling is currently set to DC. If a menu item can be toggled from one value or parameter to another, the available options will be visible, with the current option highlighted. In the example below the slope can be toggled from a rising slope to a falling slope or either slop.

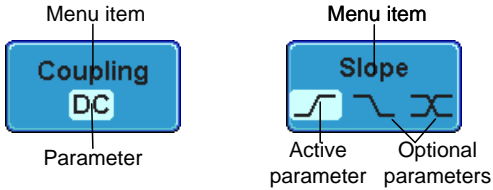

Selecting a Menu Item, Parameter or Variable

When the user manual says to “select” a value from one of the side menu parameters, first press the corresponding menu key and use the Variable knob to either scroll through a parameter list or to increase or decrease a variable.

Example 1

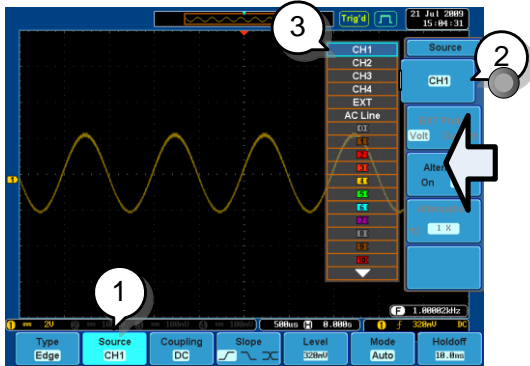

1. Press a bottom menu key to access the side menu.
2. Press a side menu key to either set a parameter or to access a sub menu.
3. If accessing a sub menu or setting a variable parameter, use the Variable knob to scroll through menu items or variables. Use the Select key to confirm and exit.

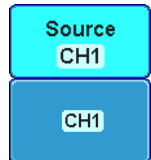

VARIABLE

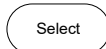
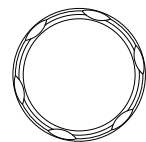

4. Press the same bottom menu key again to reduce the side menu.

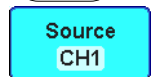

Example 2

For some variables, a circular arrow icon indicates that the variable for that menu key can be edited with the Variable knob.

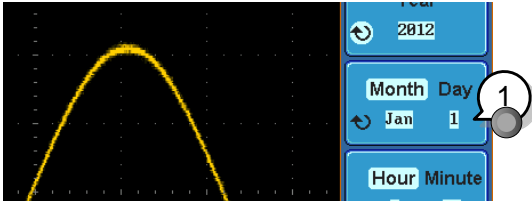

1. Press the desired menu key to select it. The circular arrow will become highlighted.

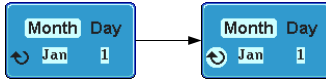

2. Use the Variable knob to edit the value.

toggling a Menu Parameter

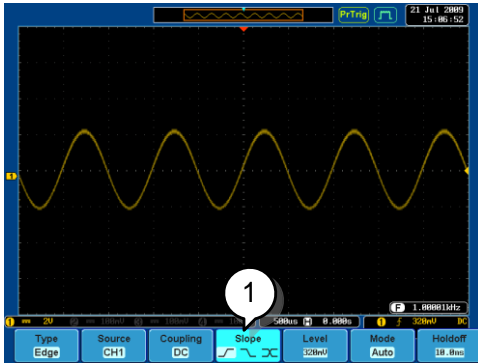

1. Press the bottom menu key to toggle the parameter.

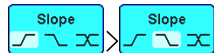

Reduce Side Menu

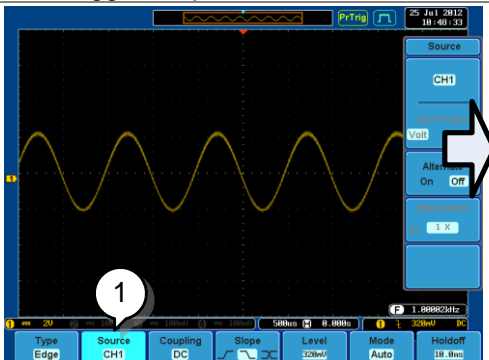

1. To reduce the side menu, press the corresponding bottom menu that brought up the side menu.

For example: Press the *Source* soft-key to reduce the Source menu.

Reduce Lower Menu

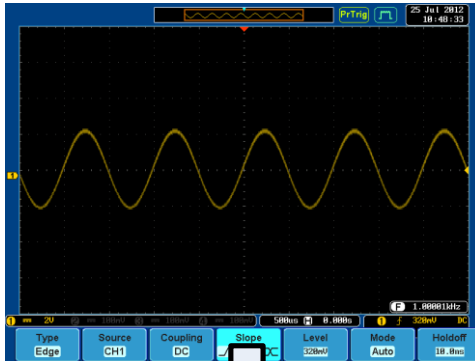

1. Press the relevant function key again to reduce the bottom menu. For example: press the Trigger Menu key to reduce the trigger menu.

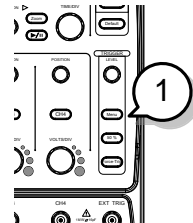

Remove All Menus

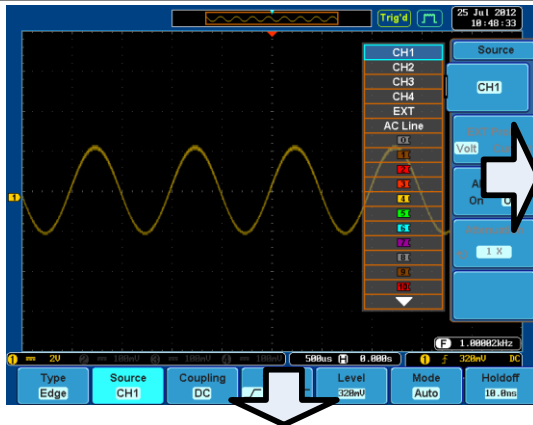

1. Press the *Menu Off* key to reduce the side menu, press again to reduce the bottom menu.

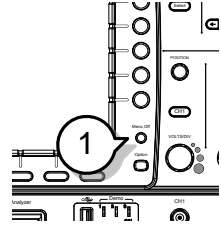

Remove
On-Screen
Messages

2. The *Menu Off* key can also be used to remove any on screen messages.

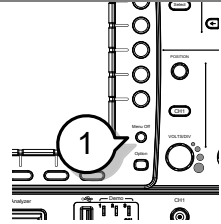

2. QUICK REFERENCE

This chapter describes the DCS-9700 menu tree, shortcuts to major operations, built-in Help access, and default factory settings. Use them as a handy reference to get a quick access to the functionality.

2-1. Menu Tree / Operation Shortcuts

2-1-1. Convention

For all menu trees, the bottom menu keys are shown as grey icons and side menu keys are shown in white. All menu tree operations are shown in order from top to bottom.

Below is an example of the menu tree operation for the trigger source menu and a comparison to the operation on the DSO screen.

Menu Tree

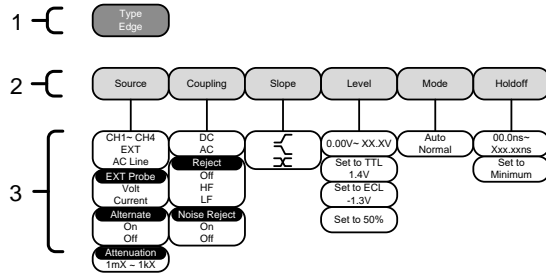

On Screen Menu

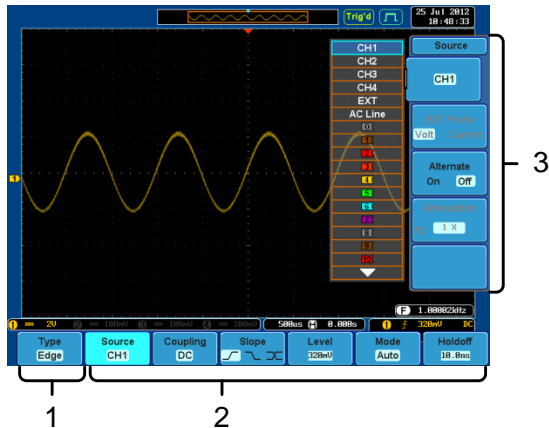

2-1-2. Acquire Key

Sets the acquisition mode.

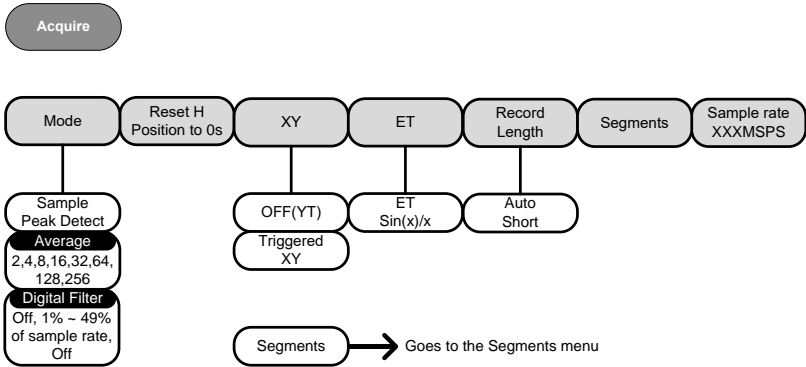

2-1-3. Acquire Key – Segments

Setup the Segmented Memory function.

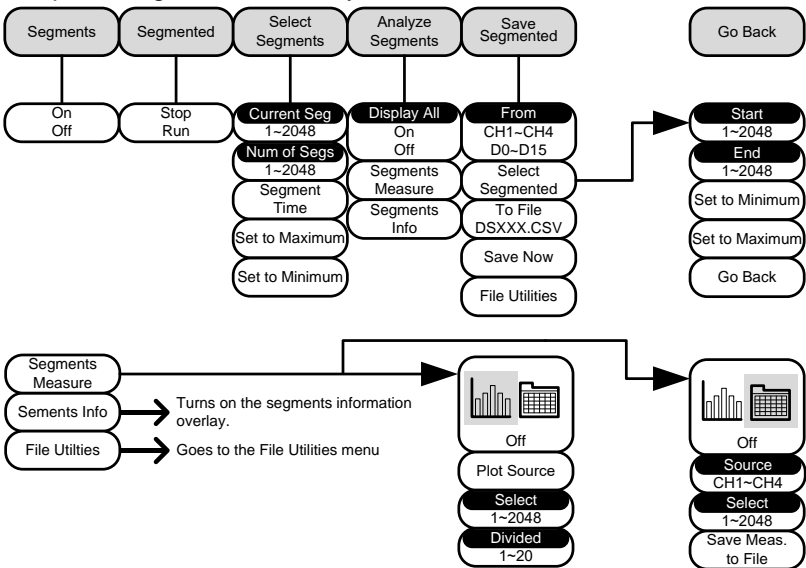

2-1-4. Autoset Key

Automatically finds the signal and sets the horizontal and vertical scale.

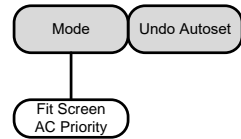

2-1-5. CH1 ~ 4 Key

Set the channel input parameters.

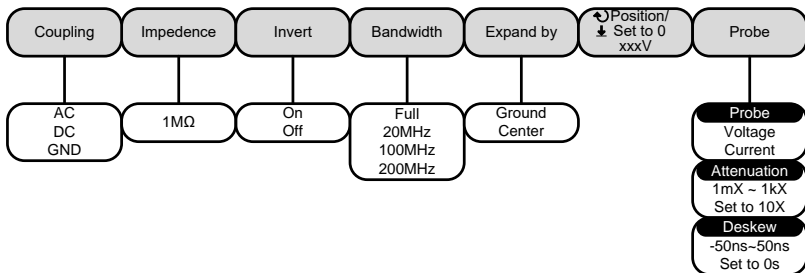
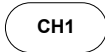

2-1-6. Cursor Key

Set cursor positions.

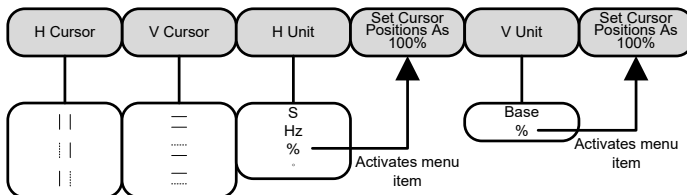

2-1-7. Display Key

Set the display properties.

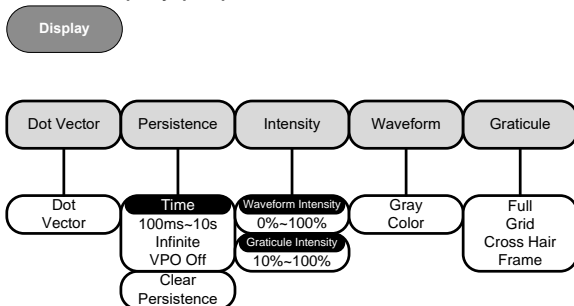

2-1-8. Help Key

Turn help mode On/Off.

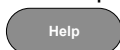

2-1-9. Math Key

Standard math and FFT functions.

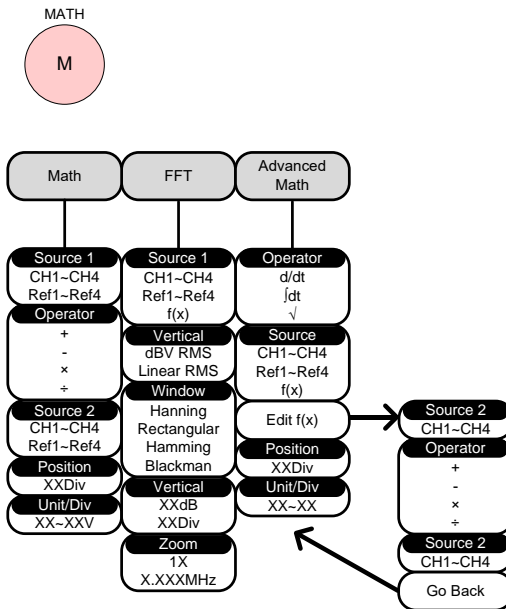

2-1-10. Measure Key

Display automatic measurements either individually or as voltage/current, time or delay measurement groups.

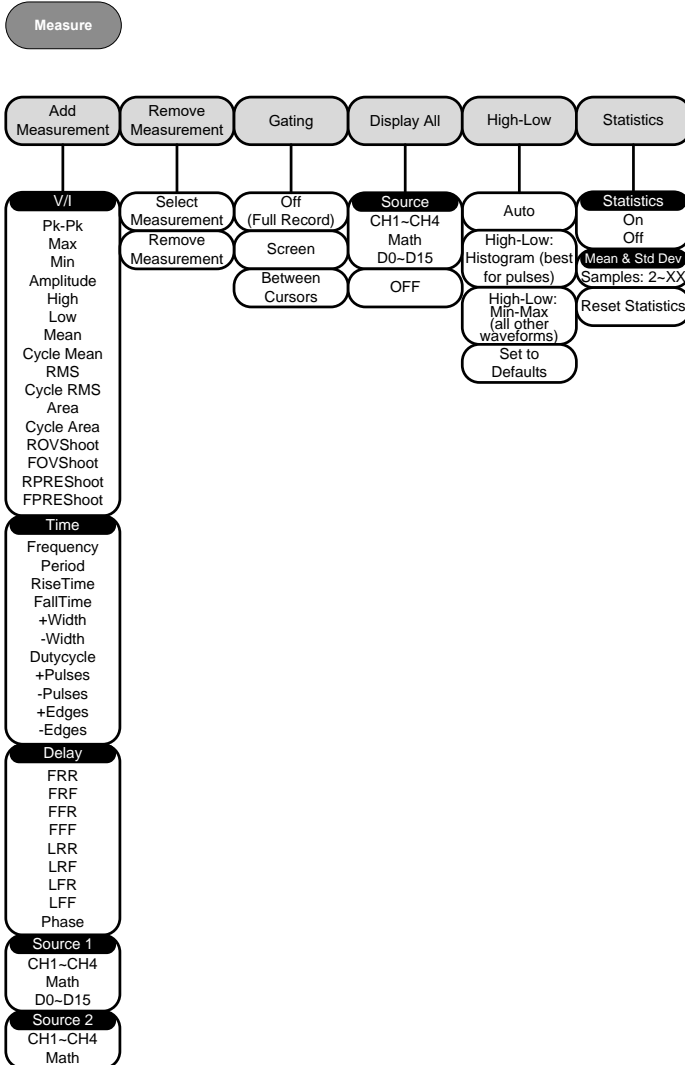

2-1-11. Hardcopy Key

Hardcopy



Print screen images or save a waveform, screen image or setup (depending on the assigned function).

2-1-12. Run/Stop Key



Run/stop signal acquisition.

2-1-13. REF Key

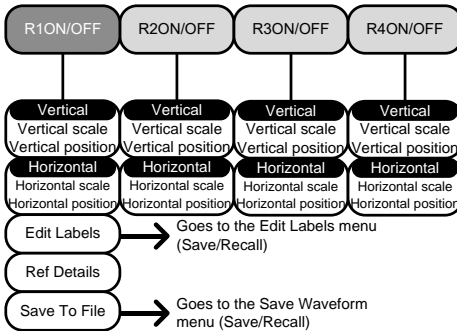
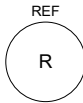

2-1-14. Save/Recall Key

Save and recall images, waveforms and panel setups. Edit labels for reference and setup files.

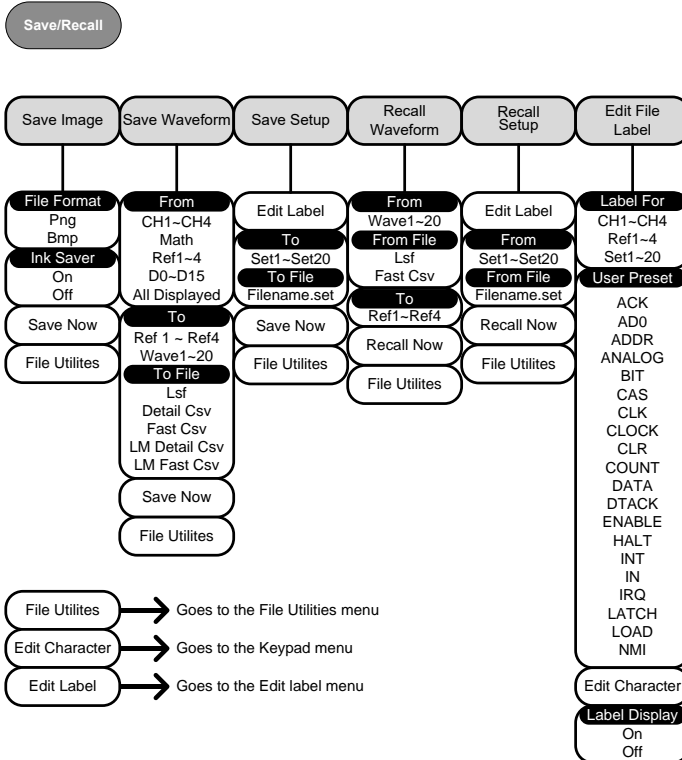

2-1-15. Test Key

Use the Go-NoGo application as well as other optional software.

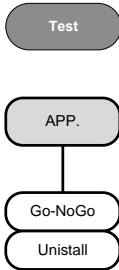

2-1-16. Test Key – Go-NoGo

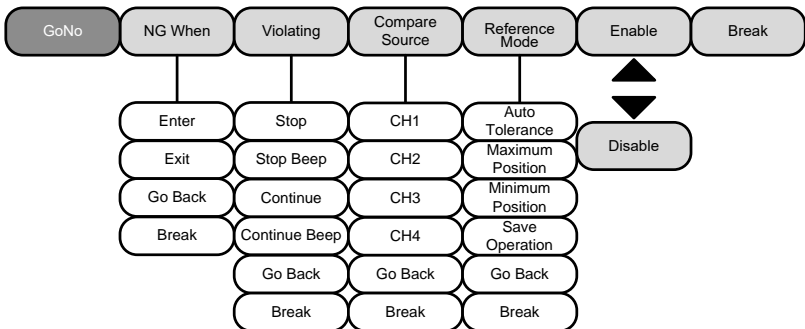

2-1-17. Trigger Type Menu

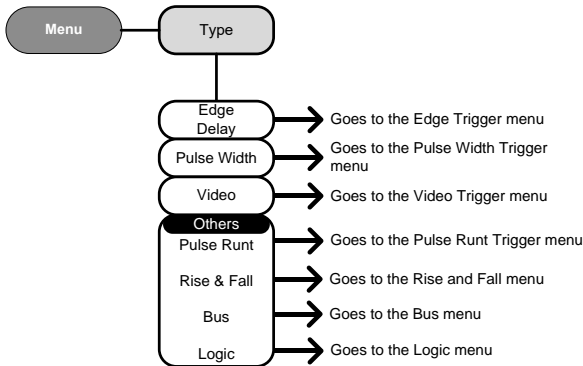

2-1-18. Trigger Edge Menu

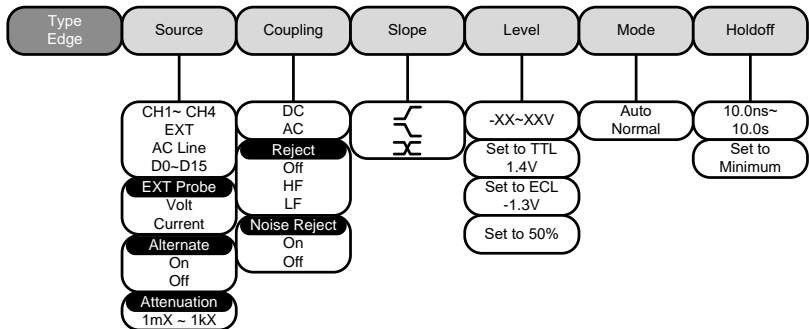

2-1-19. Trigger Delay Menu

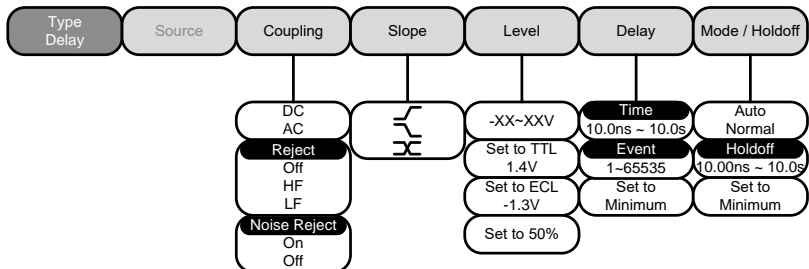

2-1-20. Trigger Pulse Width Menu

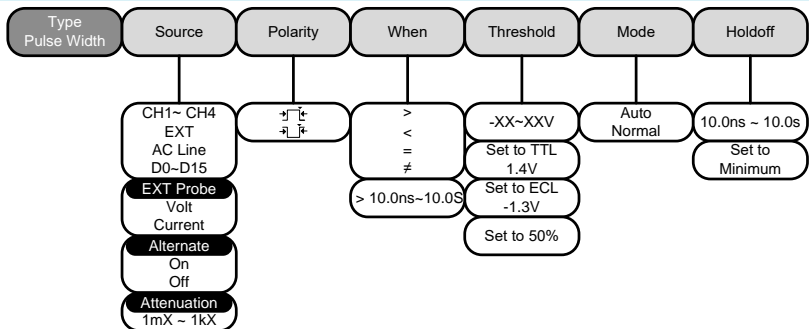

2-1-21. Trigger Video Menu

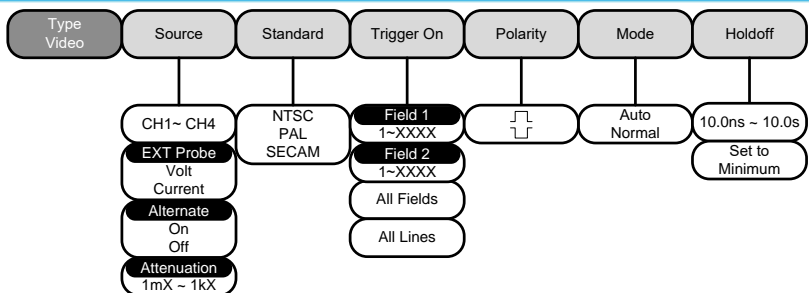

2-1-22. Trigger Pulse Runt Menu

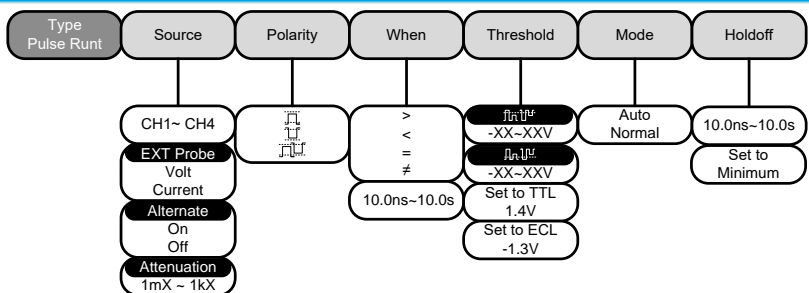

2-1-23. Trigger Rise & Fall Menu

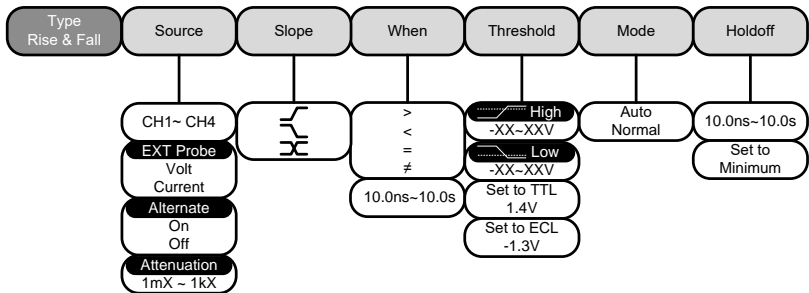

2-1-24. Trigger Timeout Menu

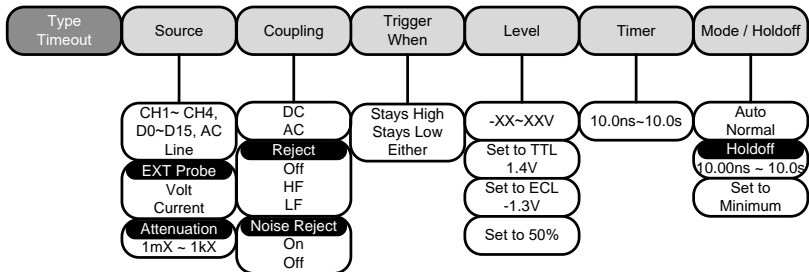

2-1-25. Utility Key

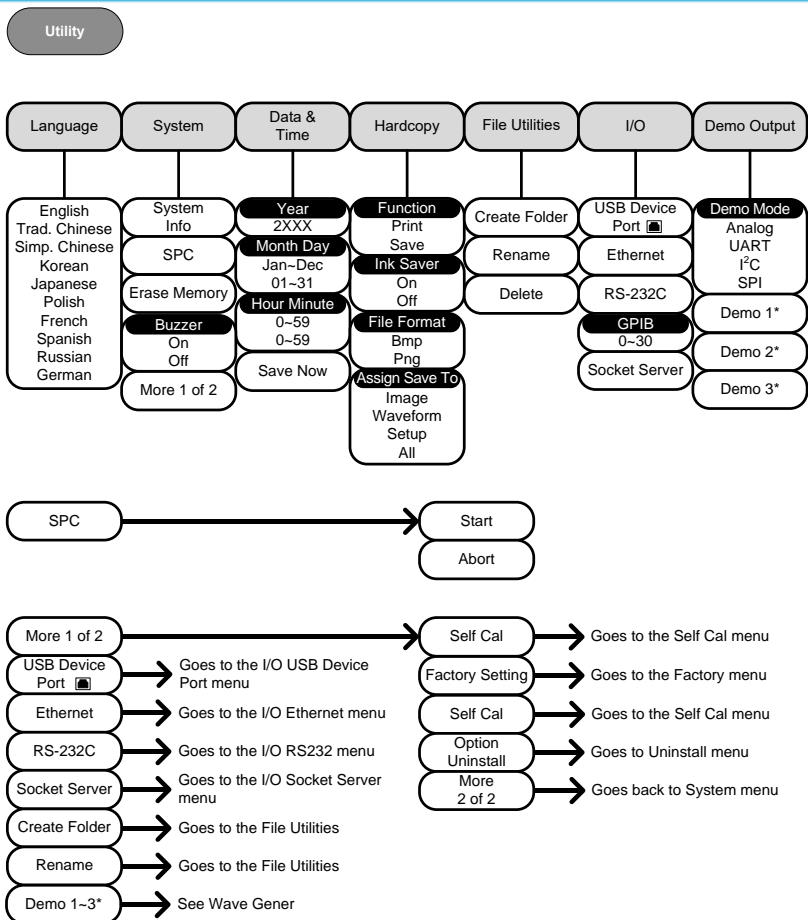

* Demo 1, Demo 2, Demo 3 outputs depend on the Demo Output settings.

2-1-26. Utility Key – I/O

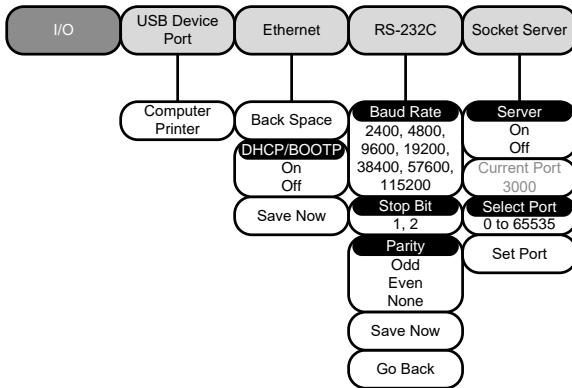

2-1-27. Utility Key – File Utilities

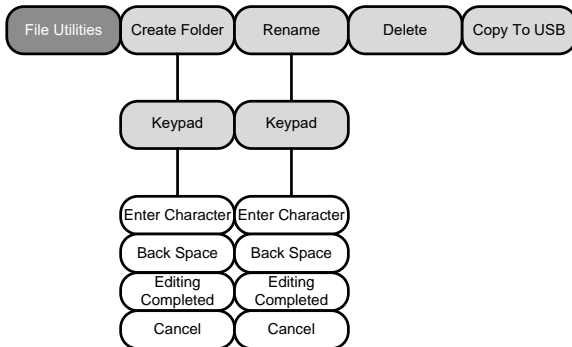

2-1-28. Utility Key – Wave Generator - Demo Outputs

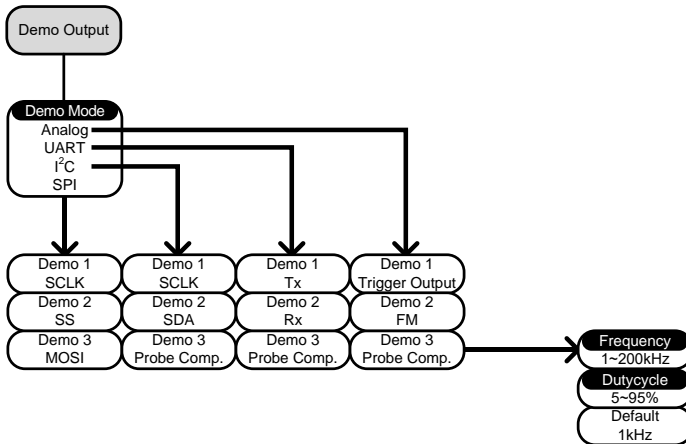

2-1-29. Search - Edge

Set the Search Function for edge events.

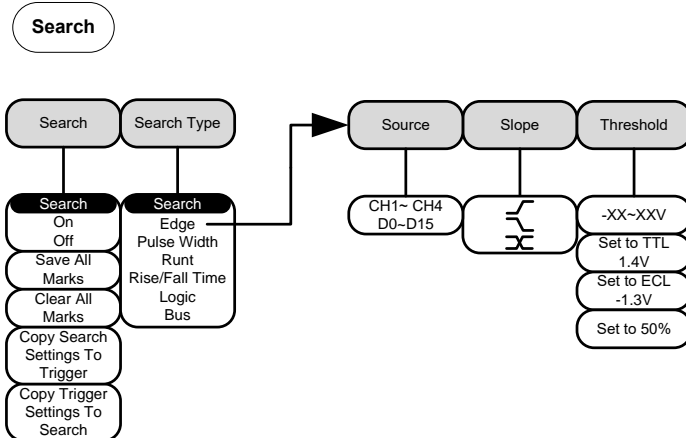

2-1-30. Search – Pulse Width

Set the Search Function for pulse width events.

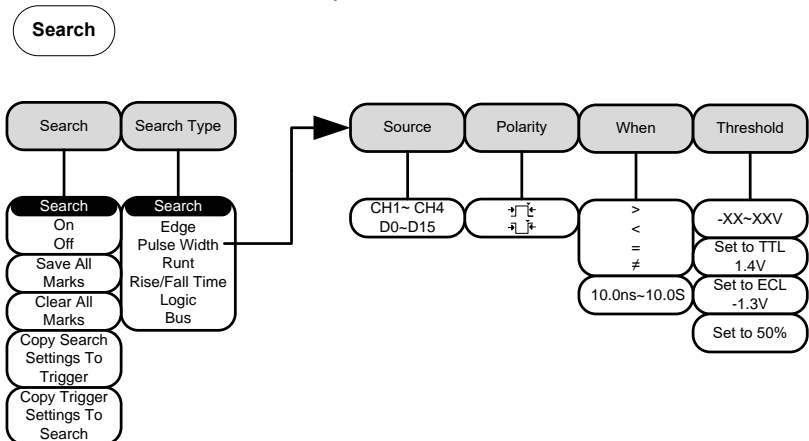

2-1-31. Search - Runt

Set the Search function for runt events.

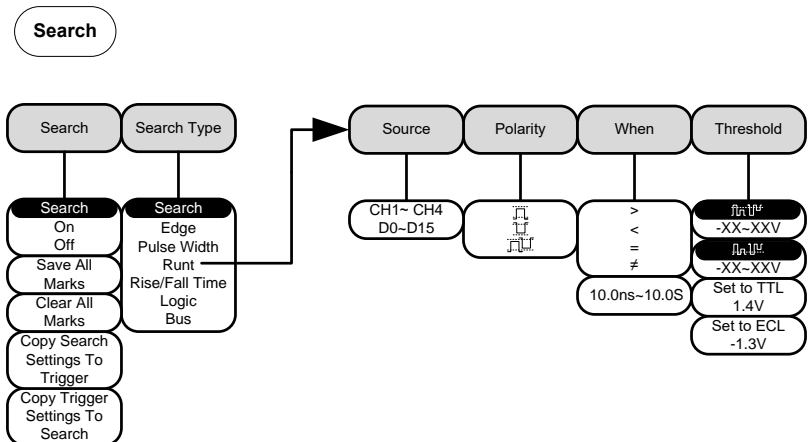

2-1-32. Search – Rise/Fall Time

Set the Search function for rise and fall time events.

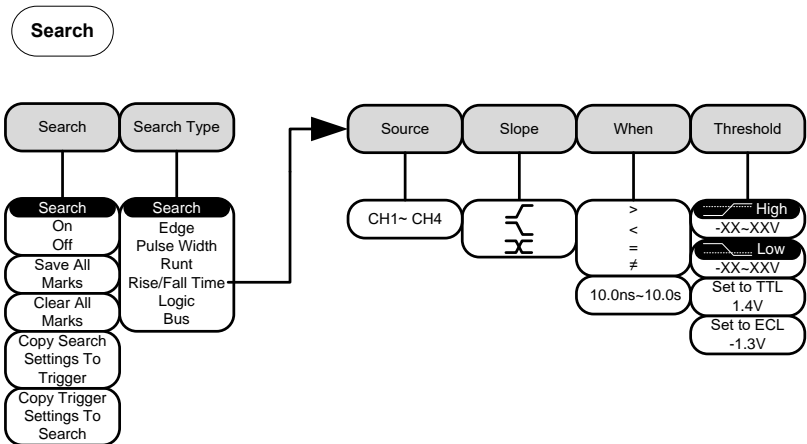

*The source bus is determined from the bus trigger settings.

2-1-33. Zoom Key

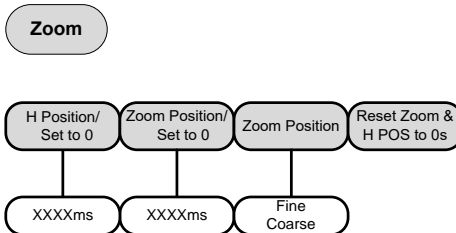

2-1-34. Option Key

Accesses the functions in the Option menu.

Option

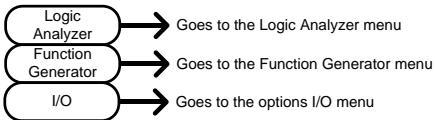
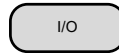
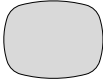

***Note:** Any option that is not installed will be grayed-out.

2-2. Default Settings

The default factory installed settings can be recalled at any time by pressing the *Default* key.

Default

Acquire	Mode: Sample Interpolation: Sin(x)/x Record Length: Auto	XY: OFF Sample rate: 2GSPS
Display	Mode: Vector Waveform intensity: 50% Waveform visuals: Gray	Persistence: 240ms Graticule intensity: 50% Graticule: full 
Channel	Scale: 100mV/Div Coupling: DC Invert: Off Expand: By ground Probe: voltage Deskew: 0s	CH1: On Impedance: 1MΩ Bandwidth: full Position: 0.00V Probe attenuation: 1x
Cursor	Horizontal cursor: Off	Vertical Cursor: Off
Measure	Source: CH1 Display: Off Statistics: Off	Gating: Screen High-Low: Auto Mean & Std Dev Samples: 2
Horizontal Math	Scale: 10us/Div Source1: CH1 Source2: CH2 Unit/Div: 200mV	Position: 0.000s Operator: + Position: 0.00 Div Math Off
Test Trigger	App: Go-NoGo Type: Edge Coupling: DC Rejection: Off Slope: Positive Mode: Auto	Source: CH1 Alternate: Off Noise Rejection: Off Level: 0.00V Holdoff: 10.0ns
Utility	Hardcopy: Save Assign Save To: Image	Ink Saver: Off File Format: Bmp
Search Segments	Search: Off Segments: Off	





2-3. Built-in Help

The Help key accesses a context sensitive help menu. The help menu contains information on how to use the front panel keys.

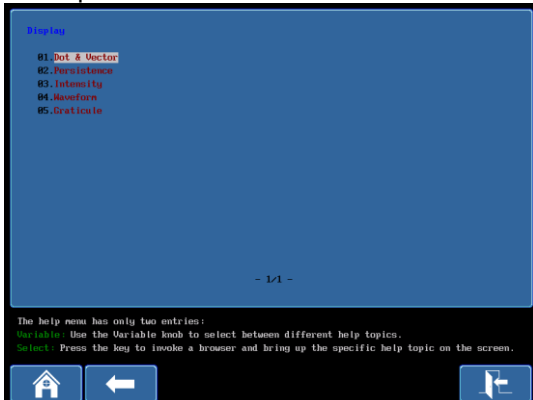
- Panel Operation
1. Press the *Help* key. The display changes to Help mode. 
 2. Use the *Variable* knob to scroll up and down through the Help contents. Press *Select* to view the help on the selected item.

Example: Help on the Display key



Home Key	Press the <i>Home</i> key to return to the main help screen.	
Go Back	Press the <i>Back</i> key to go to the previous menu page.	
Exit	Press the <i>Help</i> key again or press the <i>Exit</i> key to exit the Help mode.	 

3. MEASUREMENT

3-1. Basic Measurement

This section describes the basic operations required in capturing and viewing the input signal. For more detailed operations, see the following chapters.

- Cursor Measurement → from page 59
- Configuration → from page 70

Before operating the oscilloscope, please see the Getting Started.

3-1-1. Channel Activation

Activate Channel

To activate an input channel, press a *channel* key. When activated, the channel key will light up. The corresponding channel menu will also appear.

Each channel is associated with the color shown beside the VOLTS/DIV dial: CH1: yellow, CH2: blue, CH3: pink and CH4: green.

When a channel is activated, it is shown above the bottom menu system.

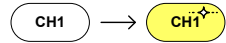
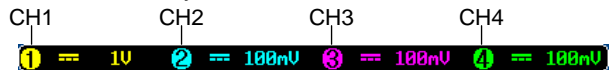

De-activate Channel

To de-activate a channel, press the corresponding *channel* key again. If the channel menu is not open, press the *channel* key twice (the first press shows the Channel menu).

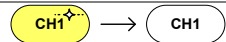

Default Setup

To activate the default state, press *Default*.



3-1-2. Autoset

Background

The Autoset function automatically configures the panel settings to position the input signal to the best viewing condition.

The DCS-9700 automatically configures the following parameters.

- Horizontal scale
- Vertical scale
- Trigger source channel

There are two operating modes for the Autoset function: Fit Screen Mode and AC Priority Mode.

Fit Screen Mode will fit the waveform to the best scale, including any DC components (offset).

AC priority mode will scale the waveform to the screen by removing any DC component.

Panel Operation

1. Connect the input signal to the DCS-9700 and press the *Autoset* key.



2. The waveform appears in the center of the display.

Before

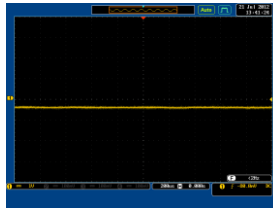

After

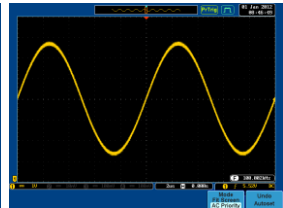

3. To undo Autoset, press *Undo Autoset* from the bottom menu.

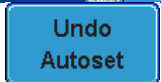

Change modes

1. Choose between *Fit Screen Mode* and *AC Priority Mode* from the bottom menu.

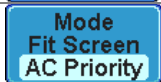

2. Press the *Autoset* key again to use Autoset in the new mode.

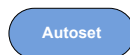

Fit Screen Mode

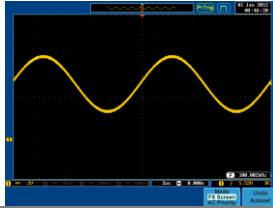

AC Priority

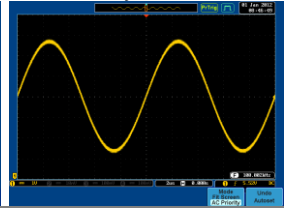

Limitation Autoset does not work in the following situations.

- Input signal frequency is less than 20Hz
- Input signal amplitude is less than 30mV



Note

The Autoset key (page 45) does NOT automatically activate the channels to which input signals are connected.

3-1-3. Run/Stop

Background

By default, the waveform on the display is constantly updated (Run mode). Freezing the waveform by stopping signal acquisition (Stop mode) allows flexible observation and analysis. To enter Stop mode, two methods are available: pressing the Run/Stop key or using the Single Trigger mode.

Stop mode icon When in Stop mode, the Stop icon appears at the top of the display.

Triggered icon

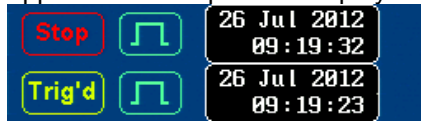

Freeze Waveform by Run/Stop Key

Press the *Run/Stop* key once. The Run/Stop key turns red. The waveform and signal acquisition freezes.

To unfreeze, press the *Run/Stop* key again. The Run/Stop key turns green again.

Stop:

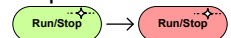

Run:

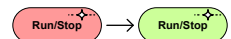

Freeze
Waveform by
Single Trigger
Mode

Press the *Single* key to go into the Single Trigger mode. The Single key turns bright white. In the Single Trigger mode, the scope will be put into the pre-trigger mode until the scope encounters the next trigger point. After the scope has triggered, it will remain in Stop mode, until the *Single* key is pressed again or the *Run/Stop* key is pressed.

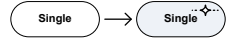

Waveform
Operation

The waveform can be moved or scaled in both Run and Stop mode, but in different manners. For details, see page 87 (Horizontal position/scale) and page 91 (Vertical position/scale).

3-1-4. Horizontal Position/Scale

For more detailed configuration, see page 87.

Set Horizontal
Position

The horizontal position knob moves the waveform left and right.

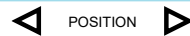

As the waveform moves, the display bar on the top of the display indicates the portion of the waveform currently shown on the display and the position of the horizontal marker on the waveform.

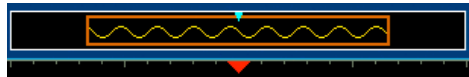

Position
Indicator

The horizontal position is shown at the bottom of the display grid to the right of H icon.

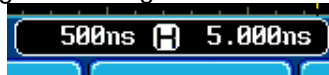

Select
Horizontal Scale

To select the timebase (scale), turn the *TIME/DIV* knob; left (slow) or right (fast).

TIME/DIV

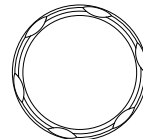

Range 1ns/div ~ 100s/div, 1-2-5 increments
The Time/Division rate is displayed to the left of the H icon at the bottom of the screen.

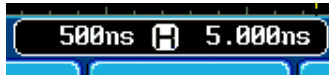

Display bar The display bar indicates how much of the waveform is displayed on the screen at any given time. Changes to timebase will be reflected on the display bar.

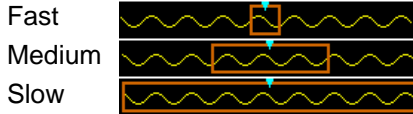

Stop mode In the Stop mode, the waveform size changes according to the scale.

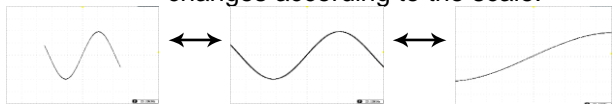

Note

The Sample rate changes according to the time/division and record length. See page 75.

3-1-5. Vertical Position/Scale

For more detailed configuration, see page 91.

Set Vertical Position

To move the waveform up or down, turn the *vertical position knob* for each channel.

POSITION



As the waveform moves, the vertical position of the cursor appears on the display.

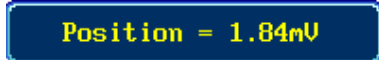

Run/Stop mode

The waveform can be moved vertically in both Run and Stop mode.

Select Vertical Scale

To change the vertical scale, turn the *VOLTS/DIV knob*; left (down) or right (up).

VOLTS/DIV

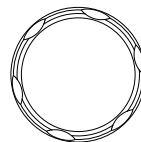

Range

1mV/div ~ 10V/div
1-2-5 increments

The vertical scale indicator for each channel on the bottom of the display changes accordingly.



3-2. Automatic Measurement













The automatic measurement function measures and updates major items for Voltage/Current, Time, and Delay type measurements.

















Measurements can be made with both the analog channels and the digital channels*, however the digital channels are only limited to a select number of time measurements. *Logic analyzer option needed for digital channels.







3-2-1. Measurement Items

	V/I Measurements	Time Meas.	Delay Meas.
Overview	Pk-Pk	Frequency*	FRR
	Max	Period*	FRF
	Min	RiseTime	FFR
	Amplitude	FallTime	FFF
	High	+Width*	LRR
	Low	-Width*	LRF
	Mean	Dutycycle*	LFR
	Cycle Mean	+Pulses	LFF
	RMS	-Pulses	Phase
	Cycle RMS	+Edges	
	Area	-Edges	
	Cycle Area		
	ROVShoot		
	FOVShoot		
	RPREShoot		
	FPREShoot		

*The logic analyzer option is needed to use the digital channels for these automatic measurements.

Voltage/Current Measurement	Pk-Pk (peak to peak)		Difference between positive and negative peak. (=max - min)
	Max		Positive peak.
	Min		Negative peak.
	Amplitude		Difference between the global high and value and the global low value, measured over the entire waveform or gated region. (=high - low)
	High		Global high voltage. See page 56 for details.
	Low		Global low voltage. See page 56 for details.
	Mean		The arithmetic mean value is calculated for all data samples as specified by the Gating option.
	Cycle Mean		The arithmetic mean value is calculated for all data samples within the first cycle found in the gated region.
	RMS		The root mean square of all data samples specified by the Gating option.
	Cycle RMS		The root mean square value is calculated for all data samples within the first cycle found in the gated region.
	Area		Measures the positive area of the waveform and subtracts it from the negative area. The ground level determines the division between positive and negative areas.
	Cycle Area		The Summation based on all data samples within the first cycle found in the gated region.

	ROVShoot		Rise overshoot
	FOVShoot		Fall overshoot
	RPREShoot		Rise preshoot
	FPREShoot		Fall preshoot
Time Measurement	Frequency		Frequency of the waveform.
	Period		Waveform cycle time. (=1/Freq)
	RiseTime		The time required for the leading edge of the first pulse to rise from the low reference value to the high reference value.
	FallTime		The time required for the falling edge of the first pulse to fall from the high reference value to the low reference value.
	+Width		Positive pulse width.
	-Width		Negative pulse width.
	Duty Cycle		Ratio of signal pulse compared with whole cycle. =100x (Pulse Width/Cycle)
	+Pulses		Measures the number of positive pulses.
	-Pulses		Measures the number of negative pulses.
	+Edges		Measures the number of positive edges.
-Edges		Measures the number of negative edges.	
Delay Measurement	FRR		Time between: Source 1 first rising edge and Source 2 first rising edge.
	FRF		Time between: Source 1 first rising edge and Source 2 first falling edge.

FFR		Time between: Source 1 first falling edge and Source 2 first rising edge.
FFF		Time between: Source 1 first falling edge and Source 2 first falling edge.
LRR		Time between: Source 1 first rising edge and Source 2 last rising edge.
LRF		Time between: Source 1 first rising edge and Source 2 last falling edge.
LFR		Time between: Source 1 first falling edge and Source 2 last rising edge.
LFF		Time between: Source 1 first falling edge and Source 2 last falling edge.
Phase		The phase difference of two signals, calculated in degrees.
		$\frac{t1}{t2} \times 360^\circ$



Note

The in-built help system can be used to see detailed automatic measurement definitions.

3-2-2. Add Measurement

The *Add Measurement* function allows you to add up to eight automatic measurement items on the bottom of the screen from any channel source.

Add Measurement Item

1. Press the *Measure* key.
2. Press *Add Measurement* from the bottom menu.
3. Choose either a *V/I*, *Time* or *Delay* measurement from the side menu and choose the type of measurement you wish to add.

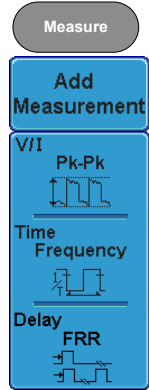

- V/I (Voltage/Current) Pk-Pk, Max, Min, Amplitude, High, Low, Mean, Cycle Mean, RMS, Cycle RMS, Area, Cycle Area, ROVShoot, FOVShoot, RPRESshoot, FPRESshoot
- Time Frequency, Period, RiseTime, FallTime, +Width, -Width, Duty Cycle, +Pulses, -Pulses, +Edges, -Edges
- Delay FRR, FRF, FFR, FFF, LRR, LRF, LFR, LFF, Phase

4. All measurements will be displayed in a window on the bottom of the screen. The channel number and channel color indicate the measurement source.
For the analog inputs: yellow = CH1, blue = CH2, pink = CH3, green = CH4.



Choose a Source

The channel source for measurement items can be set either before or when selecting a measurement item.

- To set the source, press either the *Source1* or *Source2* key from the side menu and choose the source. Source 2 is only applicable for delay measurements.

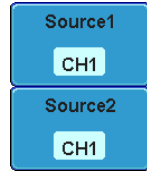



Range CH1~ CH4, Math*, D0~D15**

*The math source cannot include any digital (D0~D15) inputs.

**Only available with the Logic Analyzer option.

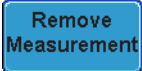

3-2-3. Remove Measurement

Individual measurements can be removed at any time using the Remove Measurement function.

Remove Measurement Item	1. Press the <i>Measure</i> key.	
	2. Press <i>Remove Measurement</i> from the bottom menu.	
	3. Press <i>Select Measurement</i> and select the item that you want to remove from the measurement list.	
Remove All Items	Press <i>Remove All</i> to remove all the measurement items.	

3-2-4. Gated mode

Some automatic measurements can be limited to a “gated” area between cursors. Gating is useful for measuring a magnified waveform or when using a fast time base. The Gated mode has three possible configurations: Off (Full Record), Screen and Between Cursors.

Set Gating Mode	1. Press the <i>Measure</i> key.	
	2. Press <i>Gating</i> from the bottom menu.	

- Choose one of the gating modes from the side menu: *Off (full record)*, *Screen*, *Between Cursors*

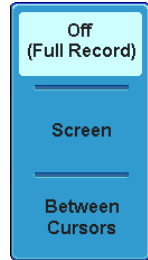

Cursors On Screen

If *Between Cursors* is selected, the cursor positions can be edited by using the cursor menu.

Page 59

3-2-5. Display All mode

Display All mode shows and updates all items from Voltage and Time type measurements.

View Measurement Results

- Press the *Measure* key.
- Press *Display All* from the bottom menu.
- Press Source from the side menu and choose a measurement source.

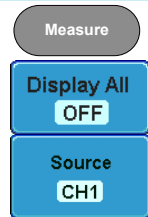

- The results of Voltage and Time type measurements appear on the display.

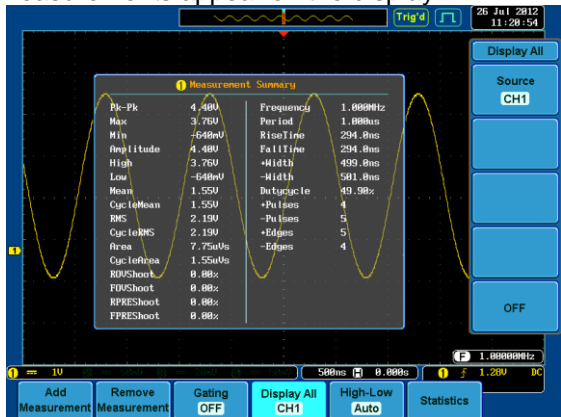

Remove Measurements

To remove the measurement results, press *OFF*.

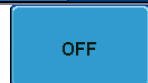

Delay Measurements	Delay type measurement is not available in this mode as only one channel is used as the source. Use the Individual measurement mode (page 53) instead.
Digital Channels	Only Frequency, Period, +Width, -Width and Duty Cycle measurements are supported for digital channels.

3-2-6. High Low Function

Background The High-Low function is used to select the method for determining the value of the High-Low measurement values.

Auto Automatically chooses the best high-low setting for each waveform when measuring.

Histogram Uses histograms to determine the high-low values. This mode ignores any preshoot and overshoot values. This mode is particularly useful for pulse-type waveforms

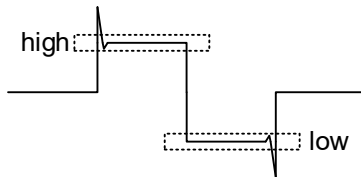

Min-max Sets the high-low values as the measured minimum or maximum measured values.

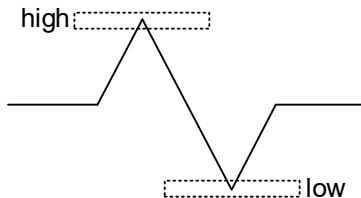

- Set High-Low**
1. Press the *Measure* key.
 2. Press *High-Low* from the bottom menu.



3. Select the type of High-Low settings from the side menu.

High-Low Settings: Histogram, Min-Max, Auto

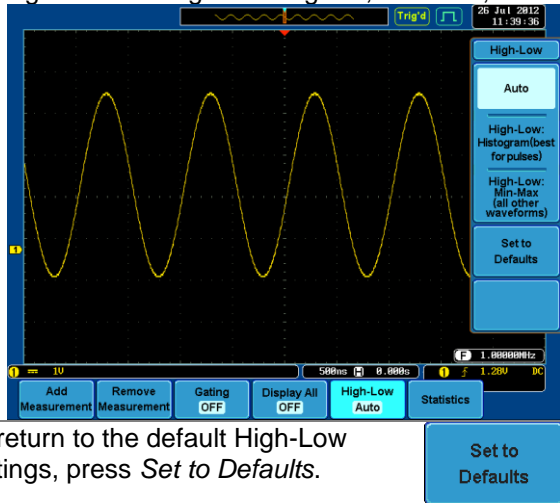

Restore Default High-Low Settings

To return to the default High-Low settings, press *Set to Defaults*.

3-2-7. Statistics

Background

The Statistics function can be used to view a number of statistics for the selected automatic measurements. The following information is displayed with the Statistics function:

Value	Currently measured value
Mean	The mean value is calculated from a number of automatic measurement results. The number of samples used to determine the mean can be user-defined.
Min	The minimum value observed from a series of measured results for the selected automatic measurement items.
Max	The maximum value observed from a series of measured results for the selected automatic measurement items.

Standard Deviation

The variance of the currently measured value from the mean. The standard deviation equals the squared root of the variance value. Measuring the standard deviation can, for example, determine the severity of jitter in a signal. The number of samples used to determine the standard deviation can be user-defined.

Set High-Low

1. Press the *Measure* key.
2. Select at least one automatic measurement.
3. Set the number of samples to be used in the mean and standard deviation calculations.
Samples: 2~1000
4. Press *Statistics* from the bottom menu and turn the Statistics function on.
5. The statistics will appear at the bottom of the display in a table.



Page 53



Reset Statistics

To reset the statistics calculations, press *Reset Statistics*.

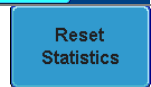

3-3. Cursor Measurement

Horizontal or vertical cursors are used to show the position and values of waveform measurements and math operation results. These results cover voltage, time, frequency and other math operations. When the cursors (horizontal, vertical or both) are activated, they will be shown on the main display unless turned off. (page 86).

3-3-1. Use Horizontal Cursors

Panel Operation/ Range 1. Press the *Cursor* key once.



2. Press *H Cursor* from the bottom menu if it is not already selected.

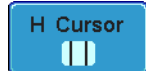

3. When the H Cursor is selected, repeatedly pressing the *H Cursor* key or the *Select* will toggle which cursor is selected.

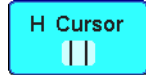

OR



Range	Description
	Left cursor (1) movable, right cursor position fixed
	Right cursor (2) movable, left cursor position fixed
	Left and right cursor (1+2) movable together

4. The cursor position information appears on the top left hand side of the screen

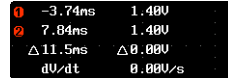

Cursor 1	Hor. position, Voltage/Current
Cursor 2	Hor. position, Voltage/Current
Δ	Delta (difference between cursors) dV/dt or dI/dt

5. Use the *Variable* knob to move the movable cursor(s) left or right.

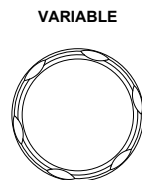

Select Units

6. To change the units of the horizontal position, press *H Unit*.

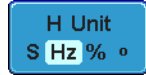

Phase or Ratio Reference

Units S, Hz, % (ratio), °(phase)
7. To set the 0% and 100% ratio or the 0° and 360° phase references for the current cursor positions, press *Set Cursor Positions As 100%*.



Example

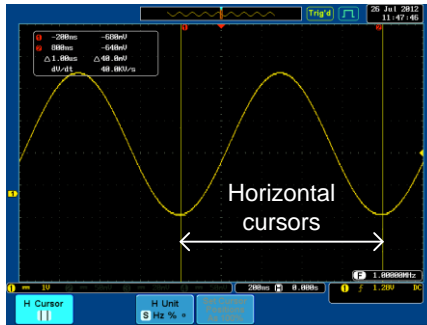

FFT

FFT cursors use different vertical units. For FFT details, see page 66.

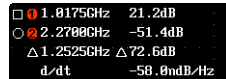

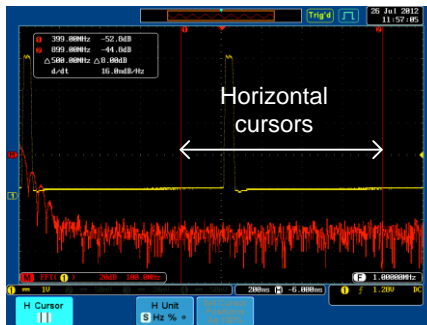

- Cursor 1 Hor. position, dB/Voltage
- Cursor 2 Hor. Position, dB/Voltage
- △ Delta (difference between cursors) dV/dt or d/dt

Example



XY Mode

XY mode cursors measure a number of X by Y measurements.

1 (X) Versus 2 (Y)	1 2 Δ			
	t:	-625ns	625ns	1.25us
Rectangular 	x:	-4.08U	-3.88U	200nU
	y:	-752nU	-752nU	0.00U
Polar 	r:	4.14U	3.95U	200nU
	θ:	-169°	-169°	0.00°
Product 	x×y:	3.06UU	2.91UU	0.00UU
Ratio	y÷x:	184nU/U	193nU/U	0.00U/U

Cursor 1 Time, rectangular, polar coordinates, product, ratio.

Cursor 2 Time, rectangular, polar coordinates, product, ratio.

Δ Delta (difference between cursors)
Horizontal cursors

Example



3-3-2. Use Vertical Cursors

Panel Operation/ Range 1. Press the *Cursor* key twice.

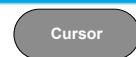

2. Press *V Cursor* from the bottom menu if it is not already selected.

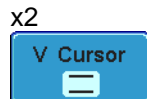

3. When the *V Cursor* is selected, repeatedly pressing the *V Cursor* key or the *Select* key will toggle which vertical cursor is selected.

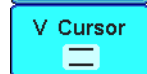

OR

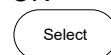

Range

- Upper cursor movable, lower cursor position fixed
- Lower cursor movable, upper cursor position fixed
- ===== Upper and lower cursor movable together

4. The cursor position information appears on the top left hand side of the screen.

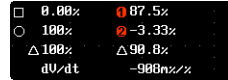

- , ○ Time: cursor 1, cursor 2
- ①, ② Voltage/Current: cursor1, cursor2
- △ Delta (difference between cursors)
- dV/dt or dI/dt

5. Use the *Variable* knob to move the cursor(s) up or down.

VARIABLE

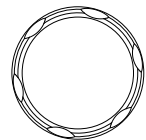

Select Units

6. To change the units of the vertical position, press *V Unit*.

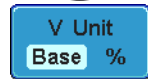

Base or Ratio Reference

7. To set the 0% and 100% ratio references for the current cursor position, press *Set Cursor Positions As 100%*.

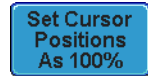

Example

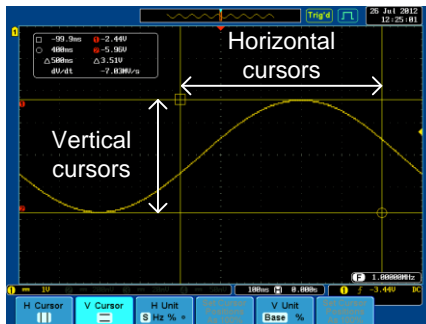

FFT

FFT has different content. For FFT details, see page 66.

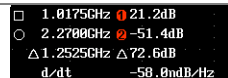



Frequency/Time: cursor1, cursor2
 dB/V: cursor1, cursor2
 Delta (difference between cursors)

Example

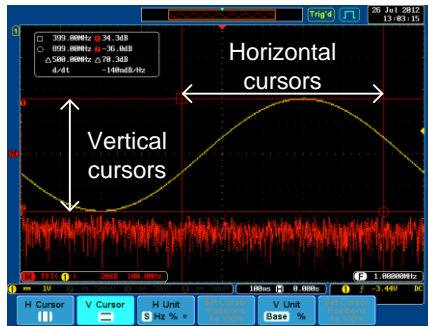

XY Mode

XY mode cursors measure a number of X by Y measurements.

1 (X) Versus 2 (Y)	1 2 Δ		
	t:		
Rectangular 	x: -1.88V y: 2.00V	120nV 0.00V	2.00V -2.00V
Polar 	r: 2.74V θ: 133°	120nV 0.00°	2.82V -45.0°
Product 	x×y: -3.76VV	0.00VV	-4.00VV
Ratio	y÷x: -1.06V/V	0.00V/V	-1.00V/V

Cursor 1 Rectangular, polar co-ordinates, product, ratio.

Cursor 2 Rectangular, polar co-ordinates, product, ratio.

△ Delta (difference between cursors)

Example

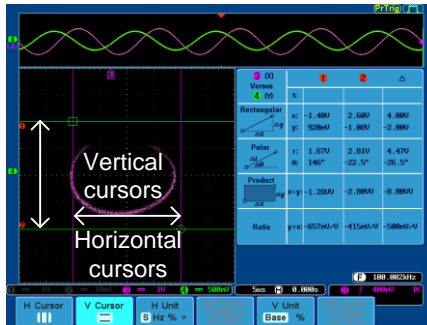

3-4. Math Operation

3-4-1. Overview

Background Math operation runs addition, subtraction, multiplication, division, FFT, or certain advanced math functions for waveform manipulations using the input signals or reference waveforms (Ref1~4) and shows the result on the display. The resulted waveform characteristics can be measured using the cursors.

Addition (+) Adds the amplitude of two signals.

Source CH1~4, Ref1~4

Subtraction (-) Extracts the amplitude difference between two signals.

Source CH1~4, Ref1~4

Multiplication (x) Multiplies the amplitude of two signals.

Source CH1~4, Ref1~4

Division (÷) Divides the amplitude of two signals.

Source CH1~4, Ref1~4

FFT Runs FFT calculations on a signal. Four types of FFT windows are available: Hanning, Hamming, Rectangular, and Blackman.

Source CH1~4, Ref1~4, f(x)

d/dt Differentiate the source waveform.

Source CH1~4, Ref1~4, f(x)

∫dt Integrate the source waveform with respect to time.

Source CH1~4, Ref1~4, f(x)

√ Performs a square root calculation.

Source CH1~4, Ref1~4, f(x)

Hanning FFT Window Frequency resolution Good

	Amplitude resolution Suitable for....	Not good Frequency measurement on periodic waveforms
Hamming FFT Window	Frequency resolution Amplitude resolution Suitable for....	Good Not good Frequency measurement on periodic waveforms
Rectangular FFT Window	Frequency resolution Amplitude resolution Suitable for....	Very good Bad Single-shot phenomenon (this mode is the same as having no window at all)
Blackman FFT Window	Frequency resolution Amplitude resolution Suitable for....	Bad Very good Amplitude measurement on periodic waveforms

3-4-2. Addition/Subtraction/Multiplication/Division

Panel Operation 1. Press the *Math* key.



2. Press the *Math* key on the lower bezel.

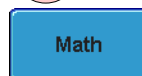

3. Select *Source 1* from the side menu

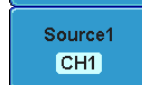

Range CH1~4, Ref~4

4. Press *Operator* to choose the math operation.

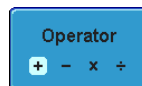

Range +, -, x, ÷

5. Select *Source 2* from the side menu.

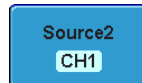

Range CH1~4, Ref~4

6. The math measurement result appears on the display. The vertical scale of the math waveform appears at the bottom of the screen.



From left: Math function, source1, operator, source2, Unit/div

Example

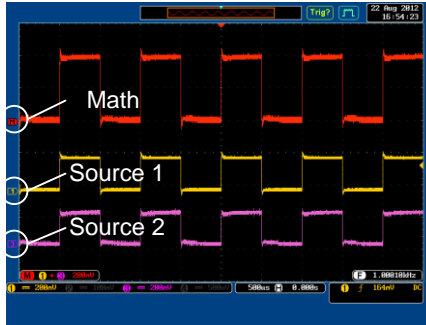

Position and Unit

To move the math waveform vertically, press the *Position* key from the side menu and use the Variable knob to set the position.



Range -12.00 Div ~ +12.00 Div

To change the unit/div settings, press *Unit/div*, then use the Variable knob to change the unit/div.

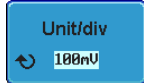

The units that are displayed depend on which operator has been selected, and whether the probe for the selected channel has been set to voltage or current.

Operator:	Unit/div:
Multiplication	VV, AA or W
Division	V/V, A/A
Addition/Subtraction	V or A

Turn Off Math

To turn off the Math result from the display, press the *Math* key again.



3-4-3. FFT

Panel Operation 1. Press the *Math* key.



2. Press *FFT* from the bottom menu.

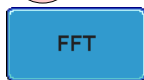

3. Select the *Source* from the side menu.

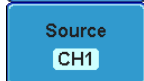

Range CH1~4, Ref~4, $f(x)^*$

*the $f(x)$ source is set in the advanced math function, page 69.

4. Press the *Vertical Units* key from the side menu to select the vertical units used.

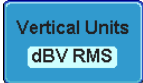

Range Linear RMS, dBV RMS

5. Press the *Window* key from the side menu and select the window type.



Range Hanning, Hamming, Rectangular, and Blackman.

6. The FFT result appears. For FFT, the horizontal scale changes from time to frequency, and the vertical scale from voltage/current to dB/RMS.

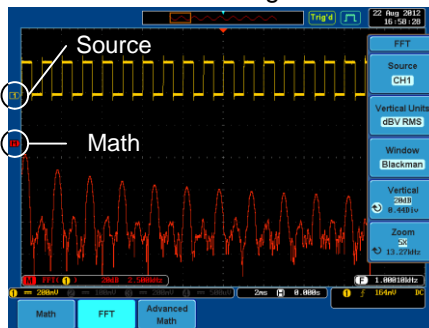

Position and Scale

To move the FFT waveform vertically, press *Vertical* until the *Div* parameter is highlighted and then use the Variable knob.



Range -12.00 Div ~ +12.00 Div

To select the vertical scale of the FFT waveform, press *Vertical* until the *dB* or *voltage* parameters are highlighted and then use the Variable knob.

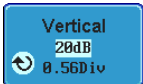

Range 2mV~1kV RMS, 1~20 dB

Zoom and Offset To zoom into the FFT waveform, press *Zoom* until the *x times* parameter is highlighted and then use the Variable knob.

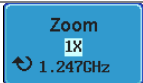

Range 1x ~ 20x

To horizontally offset the FFT waveform, press *Zoom* until the *frequency* parameter is highlighted and then use the Variable knob.

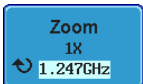

Clear FFT

To clear the FFT result from the display, press the *Math* key again.

MATH

M

3-4-4. Advanced Math

Background

The advanced math function is used to perform a number of advanced math functions such as differentiation or integration of a source waveform. The $f(x)$ source function (as used in the FFT function) can also be set from the advanced menu.

Panel Operation

1. Press the *Math* key.

MATH

M

2. Press *Advanced Math* from the bottom menu.

Advanced Math

3. Select the *Operator* from the side menu.

Operator
d/dt

Range $d/dt, \int dt, \sqrt{\quad}$

4. Select the *Source* from the side menu.

Source
CH1

Range CH1~4, Ref~4, $f(x)^*$

*the $f(x)$ source is set with the *Edit F(x)* function, page 69.

5. The math result appears. For the differential/integral operations, the unit/div scale changes accordingly.

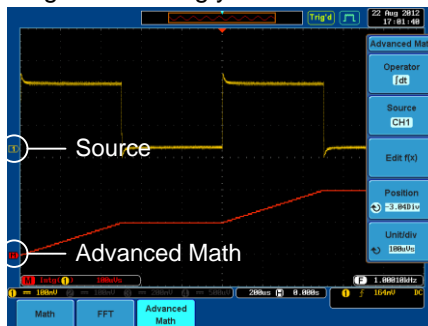





Position and Unit

To move the math waveform vertically, press *Position* and use the Variable knob.

Position
0.00Div

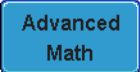
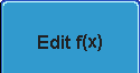
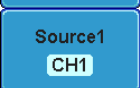
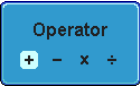
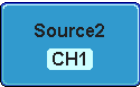
Range $-12.00 \text{ Div} \sim +12.00 \text{ Div}$

	To select the vertical scale of the math waveform, press <i>Unit/div</i> and use the <i>Variable knob</i> .	
Clear Advanced Math	To clear the advanced math result from the display, press the <i>Math</i> key again.	
3-4-5. Edit F(x)		
Background	The $f(x)$ source is a user-defined math function that can be used as a source waveform for the FFT or advanced math functions. The $f(x)$ source waveform is created by the addition, subtraction, multiplication or division of two input waveforms.	
Panel Operation	<ol style="list-style-type: none"> 1. Press the <i>Math</i> key. 2. Press <i>Advanced Math</i> from the bottom menu. 3. Press the <i>Edit f(x)</i> key to edit the $f(x)$ waveform. 4. Select <i>Source 1</i> from the side menu Range CH1~4 5. Press <i>Operator</i> to choose the math operation. Range +, -, x, ÷ 6. Select <i>Source 2</i> from the side menu. Range CH1~4 7. The $f(x)$ source waveform is now set, press <i>Go Back</i> to return to the Advanced Math menu. 	      

4. CONFIGURATION

4-1. Acquisition

The Acquisition process samples the analog input signals and converts them into digital format for internal processing.

4-1-1. Select Acquisition Mode

Background	The acquisition mode determines how the samples are used to reconstruct a waveform.
Sample	This is the default acquisition mode. Every sample from each acquisition is used.
Peak detect	Only the minimum and maximum value pairs for each acquisition interval (bucket) are used. This mode is useful for catching abnormal glitches in the signal.
Average	Multiple acquired data is averaged. This mode is useful for drawing a noise-free waveform. To select the average number, use the Variable knob. Average number: 2, 4, 8, 16, 32, 64, 128, 256

Panel Operation 1. Press the *Acquire* key.



2. To set the Acquisition mode, press *Mode* on the bottom menu.



3. Select an acquisition mode from the side menu.

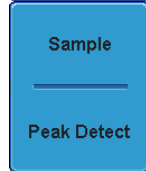

4. If *Average* was chosen, set the number of samples to be used for the average function.

Mode	Sample, Peak Detect, Average
Average sample	2, 4, 8, 16, 32, 64, 128, 256



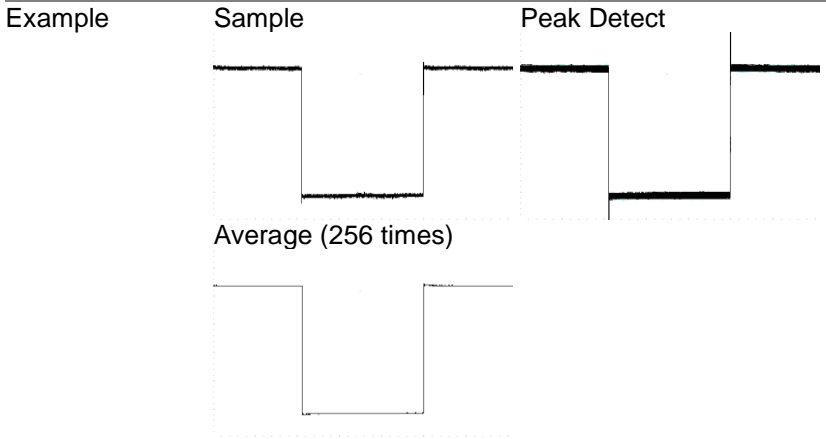

4-1-2. Digital Filter

Background The digital filter function can remove unwanted components, such as noise, from the desired signal. The filtering only functions during continuous acquisition using either the Sample or Peak detect mode. The cut-off frequency range and step resolution of the digital filter is expressed as a fraction of the underlying sample rate, as shown below.

Range	1% ~ 49% of sample rate, Off
Resolution	1% of sample rate

- Panel Operation**
1. Press the *Acquire* key.
 2. Press *Mode* on the bottom menu.
 3. Set the acquisition mode to Sample or Peak Detect.

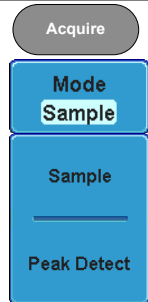

4. Press *Digital Filter* and set the digital frequency using the Variable knob.
Turn the Variable knob fully anticlockwise to turn the digital filter off.



4-1-3. Show Waveform in XY Mode

Background

The XY mode maps the input of channel 1 to the input of channel 2. the input of channel 3 can be mapped to the input of channel 4. This mode is useful for observing the phase relationship between waveforms.

Reference waveforms can also be used in XY mode. Ref1 is mapped to Ref2 and Ref3 is mapped to Ref4. Using the reference waveforms is the same as using the channel input waveforms.

Connection

1. Connect the signals to Channel 1 (X-axis) and Channel 2 (Y-axis) or Channel 3 (X2-axis) and Channel 4 (Y2-axis).

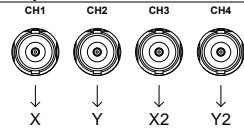

2. Make sure a channel pair is active (CH1&CH2 or CH3&CH4). Press the Channel key if necessary. A channel is active if the channel key is lit.

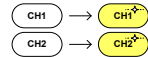

Panel Operation

1. Press the *Acquire* menu key.
2. Press *XY* from the bottom menu.
3. Choose *Triggered XY* from the side menu.

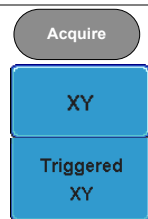

X-Y mode is split into two windows. The top window shows the signals over the full time range. The bottom window shows XY mode.

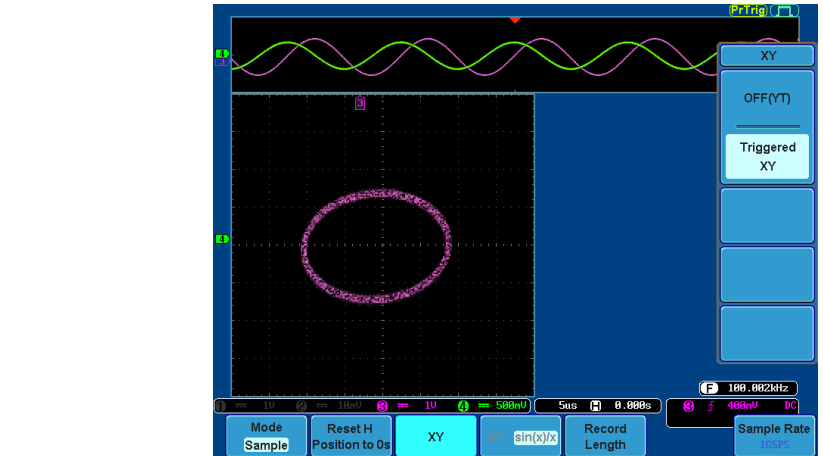

To move the X Y waveform position, use the vertical position knob: Channel 1 knob moves the X Y waveform horizontally, Channel 2 knob moves the X Y waveform vertically. Similarly, the X2 and Y2 axis can be positioned using the channel 3 and channel 4 vertical position knobs.

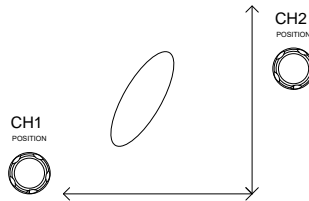

The horizontal position knob and Time/Div knob can still be used under the XY mode.

Turn Off XY Mode

To turn off XY mode, choose *OFF (YT)* mode.

OFF(YT)

XY Mode

Cursors can be used with XY mode. See the Cursors chapter for details.

Page 59

4-1-4. Set the Sampling Mode

Background

The DCS-9700 has two types of sampling modes: ET (Equivalent Time) and Sin(x)/x interpolation. Equivalent time sampling is able to achieve a sample rate of 100GSa/s when sampling periodic waveforms. Sin(x)/x interpolation uses a sinc interpolation formula to reconstruct a continuous signal between sampled points.

Sin(x)/x One sample of data is used to reconstruct a single waveform. Sin(x)/x sampling should be used when the time base is relatively slow or if single shot events need to be captured.

Equivalent-time sampling Sampled data is accumulated a number of times to reconstruct a single waveform. This increases the sampling rate, but can only be used for repetitive signals. This mode is usually used when the time base is too fast for real-time sampling.

Panel Operation 1. Press the *Acquire* key.



2. Press the *ET/sin(x)/x* key on the bottom menu to toggle between equivalent time sampling (ET) and sin(x)/x interpolation.

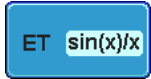

The sampling rate will be shown on the bottom right-hand corner.

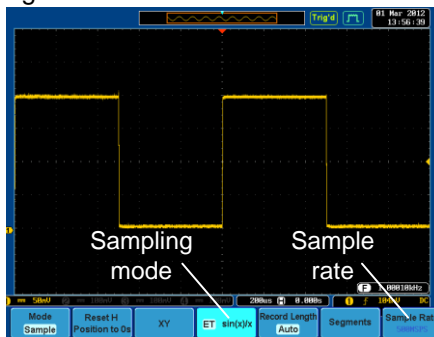

4-1-5. Set the Record Length

Background

The number of samples that can be stored is set by the record length. Record length is important in an oscilloscope as it allows longer waveforms to be recorded and/or allows higher sampling rates to be achieved when equivalent time sampling is used. There are two record length settings, Auto and Short. The Auto setting will set the record length to maximum record length available, dependent on the scope settings. The Short setting will set the record length to 1k.

The maximum record length for the DCS-9700 depends on the number of active channels, which channels are active, and whether the normal or single shot triggering mode is used. The table below describes the record lengths that are available for each triggering mode.

Channel Setting	Trigger Mode		
	Single	Normal	Auto
CH1 on	2M	1M	1M
CH2 on	2M	1M	1M
CH3 on	2M	1M	1M
CH4 on	2M	1M	1M
CH1, CH3 on	2M	1M	1M
CH1, CH4 on	2M	1M	1M
CH2, CH3 on	2M	1M	1M
CH2, CH4 on	2M	1M	1M
CH1, CH2 on	1M	500k	500k
CH3, CH4 on	1M	500k	500k
CH1, CH2, CH3 on	1M	500k	500k
CH1, CH2, CH4 on	1M	500k	500k
CH2, CH3, CH4 on	1M	500k	500k
CH1, CH3, CH4 on	1M	500k	500k
CH1, CH2, CH3, CH4 on	1M	500k	500k

Panel Operation

1. Press the *Acquire* key.
2. Press the *Record Length* key on the bottom menu and choose *Auto* or *Short* mode.



Note

The sampling rate may also be changed when the record length is changed.

4-2. Segmented Memory Acquisition

The advanced segmented memory utility allows the scope memory to be divided into different segments. Each time the scope is triggered, it only acquires data for one segment of memory at a time. This allows you to use the full potential of the scope one segment at a time. This effectively allows you to capture intermittent signal events while ignoring signal inactivity.

The Advanced Segment Memory Utility is applicable for both analog and digital channels.

4-2-1. Segments Display

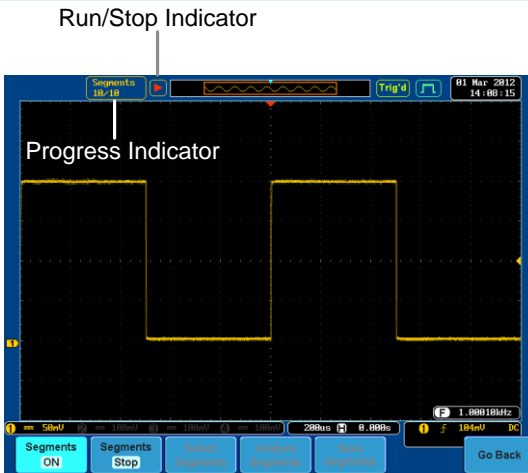

Progress Indicator

Segments
10/10

Indicates the number of segments that have to be captured relative to the set number of segments.

Run/Stop Indicator



Stop: The segments have finished acquiring or have been stopped.



Run: The scope is currently acquiring segments.

4-2-2. Set the Number of Segments

Note

Before the Segment function can be used, set the trigger settings as appropriate for the signal you wish to use.

Panel Operation 1. Press the *Acquire* key.

Acquire

2. Press *Segments* on the bottom menu.
3. Press *Select Segments* and set the number of segments from the side menu.



Logic Type	Threshold
Num of Seg	1~2048
Set to Maximum	Sets to 0 segments
Set to Minimum	Sets to 2048 segments

4-2-3. Run Segmented Memory

Background Before the Segmented Memory function can be used, set the trigger settings as appropriate for the signal you wish to use. See page 95 for configuring the trigger settings.

- Run Segments** 1. Toggle *Segments On* from the bottom menu.

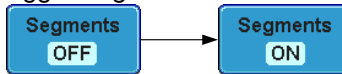

Note The first time Segmented memory is turned on the segments will automatically be run. Each segment will be automatically captured. The progress of capturing the segments is shown at the top of the display.

2. Run the segments by pressing the *Segments Run* key. Alternatively, press the *Run/Stop* key.

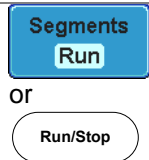

Note that the *Segments Run* key changes to *Segments Stop*.

3. The scope will automatically start acquiring segments. The progress of the segmented memory capture is shown in the Progress Indicator. The Run Indicator will be shown when in the Run mode.



- When the scope has finished acquiring segments, press the *Segments Stop* key from the bottom menu. Alternatively, press the *Run/Stop* key again. The Stop Indicator will be shown when in the Stop mode.



or



The scope is now ready to navigate or analyze the acquired segments.

4-2-4. Navigate Segmented Memory

Background

After the segmented memory acquisitions have been captured you can navigate through each segment one at a time.

Operation

- Press *Select Segments* from the bottom menu. This key will be available in the Stop mode.
- To navigate to the segment of interest, press *Current Seg* from the side menu and use the Variable knob to scroll to the segment of interest. Alternatively, the Set to Minimum and Set to Maximum keys can be used to jump to the first and last segment respectively.
- The position in time of the selected segment relative to the time of the first segment is shown in the *Segments Time* key.

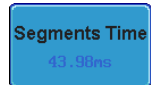
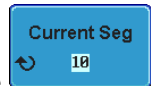

4-2-5. Segment Measurement

Background

The Segmented memory function can be used in conjunction with the automatic measurements in the Measurement menu. Please note that digital channels are not supported for measurement using segments.

Display All The Display All function will show all the acquired segments simultaneously.

- Segments Measure This function will either perform statistics calculation on the segments or tabulate a list of the measurement results.
- Segments Info Provides configuration information common for all the acquired memory segments.

4-2-6. Display All

Operation

1. Press *Analyze Segments* from the bottom menu.

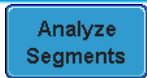

Note: This key will only be available in the Stop mode.

2. Press Display All

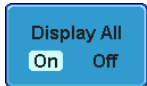





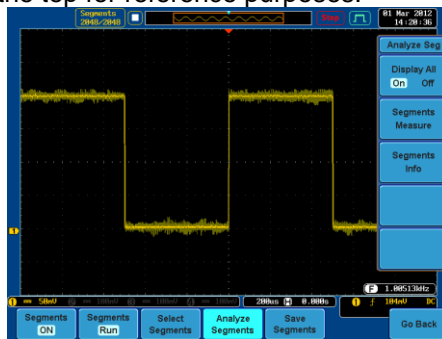

3. The display will show all the acquired segments on the display simultaneously. The currently selected segment will be superimposed over the top for reference purposes.

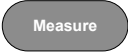
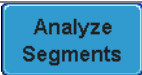
Example

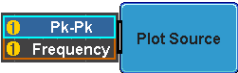

4-2-7. Automatic Measurement

Note	To use automatic measurements with the segmented memory, automatic measurements must first be selected from the Measure menu before a segment is run. Digital channels cannot be used with this function.
Setup	<p>Press the <i>Measure</i> key and select any <i>single</i> source measurement from the <i>Add Measurement</i> menu.</p>  <p>See the user manual for details on how to add automatic measurements.</p>
Operation	<ol style="list-style-type: none">1. Press <i>Analyze Segments</i> from the Segments menu. <p>Note: This key will only be available in the Stop mode.</p>2. Press <i>Segments Measure</i>. 3. Select either the statistics or the measurement list from the side menu.  Statistics  List4. The statistics table or measurement list appears on the display. Note that the more segments that you have, the longer it will take to calculate the statistics or list the measurement results.5. For statistic measurements, press <i>Plot Source</i> to choose which automatic measurement to use for the statistics calculations. 6. For the measurement list, press <i>Source</i> and select the source channel for measurement. <p>Range CH1 ~ CH4</p>

Statistics Results

This function will bin the measurement results of the selected automatic measurement into a user-defined number of bins. This allows you to easily view statistics for a large number of segments.

Setup

1. To select the number of bins for the statistics, press *Divided by* and select the number of bins with the Variable knob.
2. Press *Select* and use the Variable knob to view the measurement results for each bin.

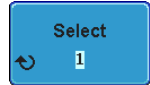
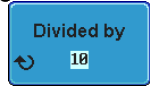

Example: Statistics

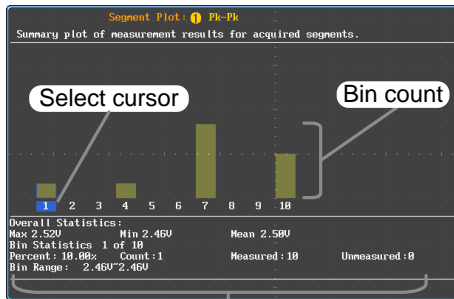

Statistics of currently selected bin

Measurement List

Puts all the measurement results for a segment in a list. All the currently selected automatic measurement results are listed.

Setup

1. Press *Select* and use the variable knob to scroll through each segment.

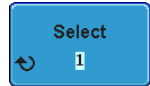

Example: Measurement List

Segment Summary

View and examine measurement results for acquired segments.



Seg.	Pk-Pk	Freq
(U)	(V)	(Hz)
1	2.50	1.001k
2	2.50	1.000k
3	2.40	1.000k
4	2.50	1.000k
5	2.50	995.0
6	2.52	1.000k
7	2.46	1.000k
8	2.52	1.000k
9	2.50	1.000k
10	2.52	1.001k

Select cursor

Measurement types

Measurement results

4-2-8. Segment Info

Operation	1. Press <i>Analyze Segments</i> from the bottom menu.	
	Note: This key will only be available in the Stop mode.	
	2. Press <i>Segments Info</i> .	
	3. A table showing all general setting information for the segmented memory acquisitions is shown on the display. Info: Sample rate, Record length, Horizontal, Vertical	



4-3. Display

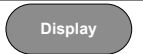
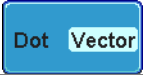

The Display menu defines how the waveforms and parameters appear on the main LCD display.

4-3-1. Display Waveform as Dots or Vectors

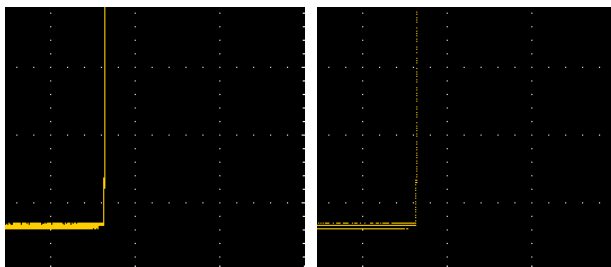

Background	When the waveform is displayed on screen, it can be displayed as dots or vectors.	
Panel Operation	1. Press the <i>Display</i> menu key.	
	2. Press <i>Dot Vector</i> to toggle between Dot and Vector mode.	
Range	Dots	Only the sampled dots are displayed.
	Vectors	Both the sampled dots and the connecting line are displayed.
Example:	Vectors (square wave)	Dots (square wave)

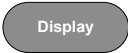

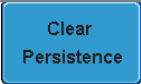
4-3-2. Set the Level of Persistence

Background	The persistence function allows the DCS-9700 to mimic the trace of a traditional analog oscilloscope. A waveform trace can be configured to “persist” for designated amount of time.
Panel Operation	<ol style="list-style-type: none"> 1. Press the <i>Display</i> menu key.  2. To set the persistence time, press the <i>Persistence</i> menu button on the bottom bezel.  3. Use the Variable knob to select a persistence time.  <p style="text-align: center;">Time 16ms~10s, Infinite, Off</p>
Clear	To clear persistence, press <i>Clear Persistence</i> . 

4-3-3. Set the Intensity Level

Background	The intensity level of a signal can also be set to mimic the intensity of an analog oscilloscope by setting the digital intensity level.
Panel Operation	<ol style="list-style-type: none"> 1. Press the <i>Display</i> menu key.  2. Press <i>Intensity</i> from the bottom menu. 
Waveform Intensity	<ol style="list-style-type: none"> 3. To set the waveform intensity, press <i>Waveform Intensity</i> and edit the intensity. Range 0~100%
Graticule Intensity	<ol style="list-style-type: none"> 4. To set the graticule intensity, press <i>Graticule Intensity</i> from the side menu and edit the intensity value. Range 10~100%

Example

Waveform Intensity 0%

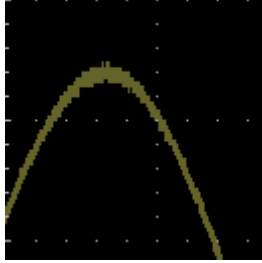

Waveform Intensity 100%

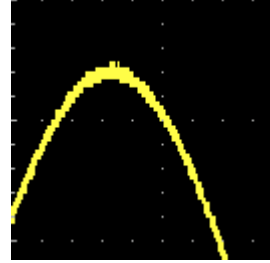

Graticule Intensity 10%

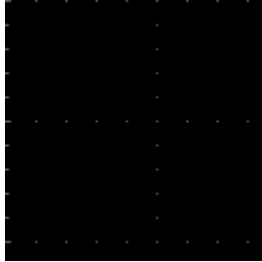

Graticule Intensity 100%

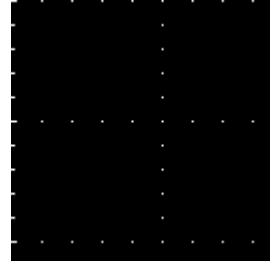

4-3-4. Set the Waveform Intensity Type

Background

The intensity gradient of a signal can be set to grayscale or color. If intensity is set to color, the intensity gradient is analogous to a thermal color gradient where high intensity areas are colored red and low intensity areas are colored blue.

Panel Operation

1. Press the *Display* menu key.



2. Press *Waveform* from the bottom menu to toggle the intensity type.



Range Gray, Color

Example

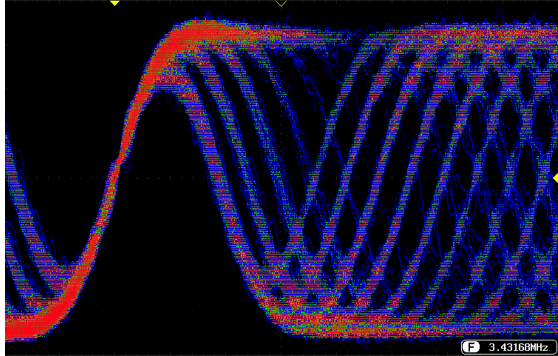

4-3-5. Select Display Graticule

Panel Operation 1. Press the *Display* menu key.

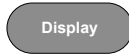

2. Press *Graticule* from the bottom menu.



3. From the side menu choose the graticule display type.

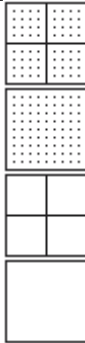

Full: Shows the full grid; X and Y axis for each division.

Grid: Show the full grid without the X and Y axis.

Cross Hair: Shows only the center X and Y frame.

Frame: Shows only the outer frame.

4-3-6. Freeze the Waveform (Run/Stop)

For more details about Run/Stop mode, see page 46.

Panel Operation 1. Press the *Run/Stop* key. The *Run/Stop* key turns red and waveform acquisition is paused.

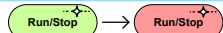

2. The waveform and the trigger freezes. The trigger indicator on the top right of the display shows Stop.



3. To unfreeze the waveform, press the *Run/Stop* key again. The *Run/Stop* key turns green again and acquisition resumes.

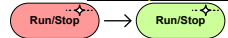

4-3-7. Turn Off Menu

- Panel Operation
1. Press the *Menu Off* key below the side menu keys to reduce a menu. The menu key needs to be pressed each time to reduce one menu.



See page 19 for more information.

4-4. Horizontal View

This section describes how to set the horizontal scale, position, and waveform display mode.

4-4-1. Move Waveform Position Horizontally

Panel Operation The horizontal position knob moves the waveform left/right.

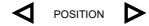

As the waveform moves, a position indicator on the top of the display indicates the horizontal position of the waveform in memory.

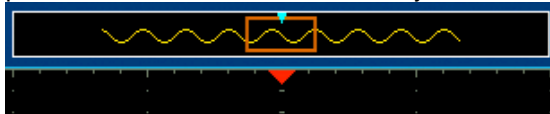

Reset Horizontal Position 1. To reset the horizontal position, press the Acquire key and then press *Reset H Position to 0s* from the bottom menu.



Run Mode In Run mode, the memory bar keeps its relative position in the memory since the entire memory is continuously captured and updated.

4-4-2. Select Horizontal Scale

Select Horizontal Scale To select the timebase (scale), turn the TIME/DIV knob; left (slow) or right (fast).

TIME/DIV

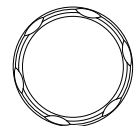

Range 1ns/div ~ 100s/div, 1-2-5 increment
The timebase indicator updates as the TIME/DIV is adjusted.

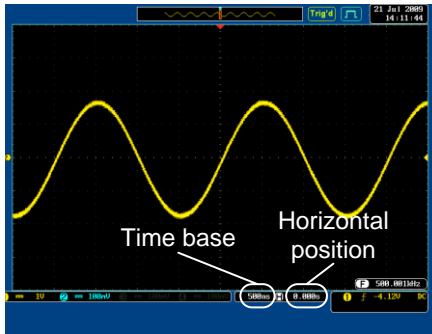

Run Mode	In Run mode, the memory bar and waveform size keep their proportion. When the time base becomes slower, roll mode is activated (if trigger is set to Auto).
Stop Mode	In Stop mode, the waveform size changes according to the scale.

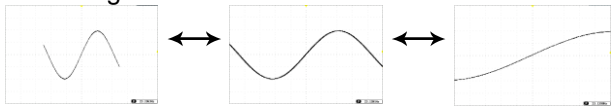

4-4-3. Select Waveform Update Mode

Background	The display update mode is switched automatically or manually according to the timebase and trigger.
Normal	Updates the whole displayed waveform at once. Automatically selected when the timebase (sampling rate) is fast. Timebase $\leq 50\text{ms/div}$ Trigger all modes
Roll Mode	Roll Updates and moves the waveform gradually from the right side of the display to the left. Automatically selected when the timebase (sampling rate) is slow. Timebase $\geq 100\text{ms/div}$ Trigger all modes

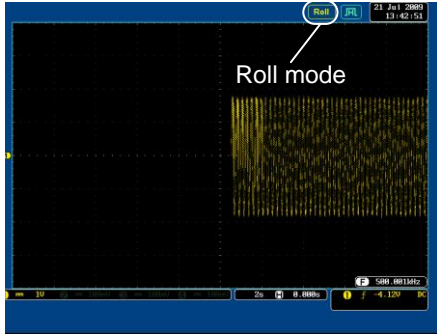

Select Roll Mode Manually

1. Press the *Trigger Menu* key.
2. Press *Mode* from the bottom menu and select *Auto (Untriggered Roll)* from the side menu.



4-4-4. Zoom Waveform Horizontally

Background

When in Zoom mode, the screen is split into 2 sections. The top of the display shows the full record length, with the bottom of the screen showing the normal view.

Panel Operation

1. Press the *Zoom* key.
2. The Zoom mode screen appears.

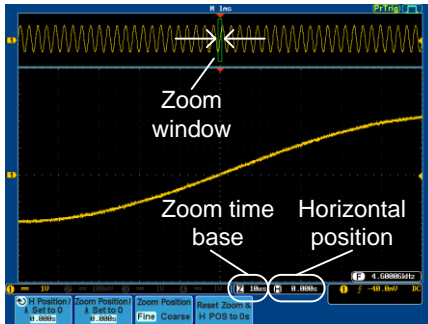
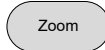



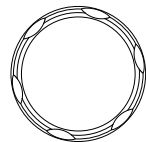

Horizontal Navigation

To scroll the waveform left or right, use the *Variable Position* knob.

VARIABLE

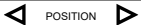

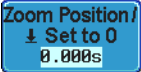
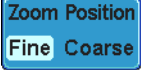
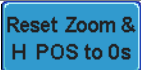
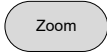
	To reset the horizontal position, press <i>H Position/Set to 0</i> .	
Zoom	To increase the zoom range, use the <i>TIME/DIV</i> knob. The zoom time base (Z) at the bottom of the screen will change accordingly.	
		
Move the Zoom Window	Use the <i>Horizontal Position</i> knob to pan the zoom window horizontally. The position of the zoom window, relative to the horizontal position is shown on the <i>Zoom Position/Set to 0</i> key.	 
	To reset the zoom position, press <i>Zoom Position/Set to 0</i> .	
Scroll Sensitivity	To alter the scrolling sensitivity of the zoom window, press the <i>Zoom Position</i> key to toggle the scrolling sensitivity. Sensitivity Fine, Coarse	
Reset the Zoom & Horizontal Position	To reset both the zoom and horizontal position, press <i>Reset Zoom & H POS to 0s</i> .	
Exit	To go back to the original view, press the <i>Zoom</i> key again.	



4-5. Vertical View (Channel)

This section describes how to set the vertical scale, position, and coupling mode.

4-5-1. Move Waveform Position Vertically

- Panel Operation
- To move the waveform up or down, turn the *vertical position* knob for each channel. POSITION 
 - As the waveform moves, the vertical position of the cursor appears at the bottom half of the display.

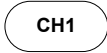
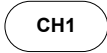
Position = 0.000

- View or Reset Vertical Position
- Press a channel key. The vertical position is shown in the  *Position / ↓Set to 0* soft key. 
 - To change the position, press  *Position / ↓Set to 0* to reset the vertical position or turn the *vertical position* knob to the desired level. 

Run/Stop Mode The waveform can be moved vertically in both Run and Stop mode.

4-5-2. Select Vertical Scale

- Panel Operation To change the vertical scale, turn the VOLTS/DIV knob; left (down) or right (up). VOLTS/DIV 

The vertical scale indicator on the bottom left of the display changes accordingly for the specific channel.

Range 1mV/div ~ 10V/div (1MΩ). 1-2-5 increments

Stop Mode In Stop mode, the vertical scale setting can be changed.

4-5-3. Select Coupling Mode

- Panel Operation
- Press a *channel* key. 

- Press *Coupling* repeatedly to toggle the coupling mode for the chosen channel.



Range		DC coupling mode. The whole portion (AC and DC) of the signal appears on the display.
		AC coupling mode. Only the AC portion of the signal appears on the display. This mode is useful for observing AC waveforms mixed with DC signals.
		Ground coupling mode. The display shows only the zero voltage level as a horizontal line.

Example Observing the AC portion of the waveform using AC coupling
DC coupling

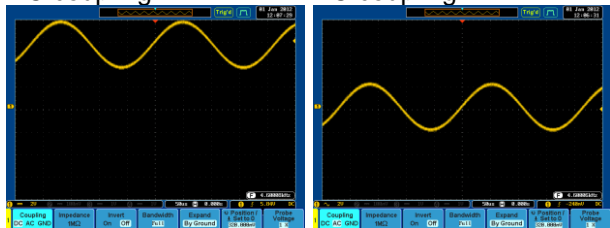

4-5-4. Input Impedance

Background The input impedance of the DCS-9700 is fixed at 1MΩ. The impedance is displayed in the channel menu.

View Impedance 1. Press the *Channel* key.



- The impedance is displayed in the bottom menu.



4-5-5. Invert Waveform Vertically

Panel Operation 1. Press the *Channel* key.

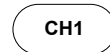

- Repeatedly press *Invert* to toggle Invert On or Off.

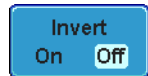

4-5-6. Limit Bandwidth

Background Bandwidth limitation puts the input signal into a selected bandwidth filter. This function is useful for cutting out high frequency noise to see a clear waveform shape. The bandwidth filters available are dependent on the bandwidth of the oscilloscope model.

- Panel Operation**
1. Press the *Channel* key.
 2. Press *Bandwidth* from the bottom menu.
 3. Choose a bandwidth* from the side menu.
- *Depending on the bandwidth of the oscilloscope.



- 70MHz Model: Full, 20MHz
100MHz Model: Full, 20MHz
200MHz Model: Full, 20MHz, 100MHz
300MHz Model: Full, 20MHz, 100MHz, 200MHz

Example

BW Full

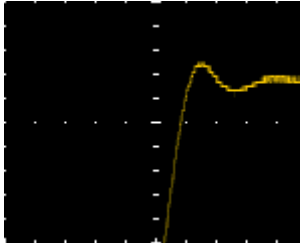

BW Limit 20MHz

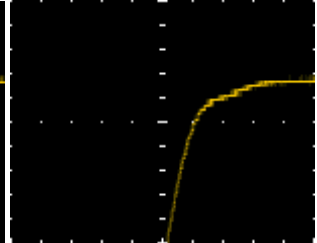

4-5-7. Expand by Ground/Center

Background When the voltage scale is changed, the Expand function designates whether the signal expands from the center of the signal or from the signal ground level. Expand by center can be used to easily see if a signal has a voltage bias. Expand by ground is the default setting.

- Panel Operation**
1. Press a *channel* key.
 2. Press *Expand* repeatedly to toggle between expand *By Ground* and *Center*.
- Range By Ground, By Center

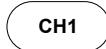

Example

If the vertical scale is changed when the Expand function is set to ground, the signal will expand from the ground level*. The ground level does not change when the vertical scale is changed.

If the vertical scale is changed when the Expand function is set to center, the signal will expand from the center of the signal. The ground level will suit to match the signal position.

*Or from the upper or lower edge of the screen if the ground level is off screen.

Expand by Ground

Expand by Center

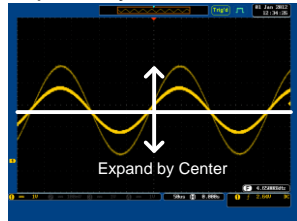
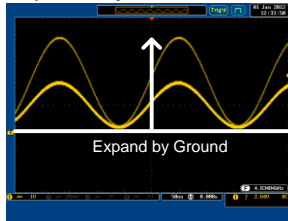

4-5-8. Select Probe Type

Background A signal probe can be set to voltage or current.

Panel Operation 1. Press the *Channel* key.

CH1

2. Press *Probe* from the bottom menu.

Probe
Voltage
1 X

3. Press the *Voltage/Current* soft-key to toggle between voltage and current.

Voltage
Current

4-5-9. Select Probe Attenuation Level

Background A signal probe has an attenuation switch to lower the original DUT signal level to the oscilloscope input range, if necessary. The probe attenuation selection adjusts the vertical scale so that the voltage level on the display reflects the real value on a DUT.

Panel Operation 1. Press the *Channel* key.

CH1

2. Press *Probe* from the bottom menu.

Probe
Voltage
1 X

3. Press *Attenuation* on the side menu and use the Variable knob to set the attenuation.
Alternatively, press *Set to 10X*.



Range 1mX ~1kX (1-2-5 step)



Note

The attenuation factor adds no influence on the real signal. It just changes the voltage/current scale on the display.

4-5-10. Set the Deskew

Background The deskew function is used to compensate for the propagation delay between the oscilloscope and the probe.

Panel Operation 1. Press one of the *Channel* keys.

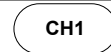

2. Press *Probe* from the bottom menu.
3. Press *Deskew* on the side menu and use the Variable knob to set the deskew time.
Alternatively, press *Set to 0s* to reset the deskew time.

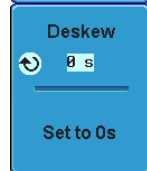
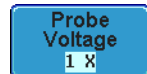

Range -50ns~50ns, 10ps increments

4. Repeat the procedure for another channel if necessary.

4-6. Trigger

The trigger configures the conditions for when the DCS-9700 captures a waveform.

The following trigger overview only applies to the analog channels, for triggering details using the optional logic analyzer module, please see the DCS-9700 Options User Manual for details.

4-6-1. Trigger Type Overview

Edge The edge trigger is the simplest trigger type. An edge trigger triggers when the signal crosses an amplitude threshold with either a positive or negative slope.

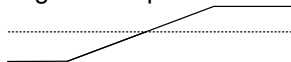

Rising edge trigger

Falling edge trigger

Delay

The Delay trigger works in tandem with the edge trigger, by waiting for a specified time (duration) or number of events before the edge trigger starts. This method allows pinpointing a location in a long series of trigger events.

Note: when using the delay trigger, the edge trigger source can be any one of the channel inputs, the EXT input or the AC line.

Delay trigger example (by event)

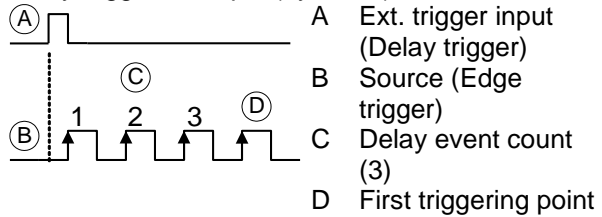

Delay trigger example (by time)

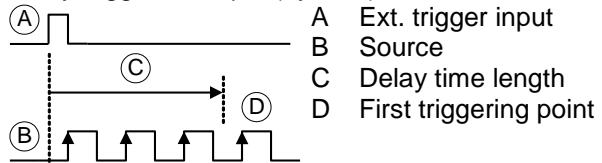

Pulse Width (glitch)

Triggers when the pulse width (glitch) of the signal is less than, equal, not equal or greater than a specified pulse width (glitch).



Video

Extracts a sync pulse from a video format signal, and triggers on a specific line or field.

Pulse and Runt

Triggers on a "runt". A runt is a pulse that passes a specified threshold but fails to pass a second threshold. Both positive and negative runts can be detected.

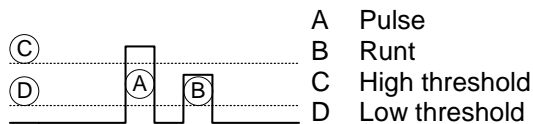

Rise and Fall Trigger on rising and or falling edges, below or over a specified rate. The threshold can also be specified.

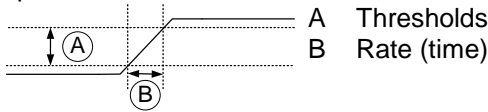

Timeout Triggers when the signal stays high, low or either for a designated amount of time. The trigger level determines when a signal is high or low.

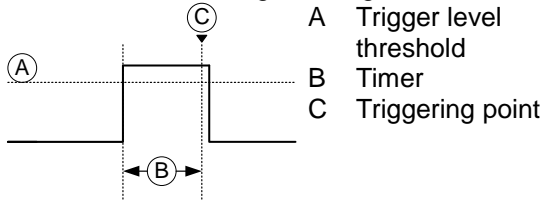

4-6-2. Trigger Parameter Overview

All the following parameters are common for all the trigger types unless stated otherwise.

Trigger Source CH1 ~ 4 Channel 1 ~ 4 input signals
 EXT External trigger input **EXT TRIG** signal

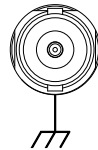





AC Line AC mains signal





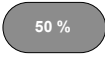

Alternate Alternate between channel sources for the trigger source.

EXT Probe Probe trigger source. Set the probe as either current or voltage.

Trigger Mode Auto (un-triggered roll) The DCS-9700 generates an internal trigger if there is no trigger event, to make sure waveforms are constantly updated regardless of trigger events. Select this mode especially when viewing rolling waveforms at slower timebases.

Normal The DCS-9700 acquires a waveform only when a trigger event occurs.

	Single	The DCS-9700 acquires a waveform once when a trigger event occurs, then stops acquiring. Press the Single key to acquire a waveform again.	
Coupling (Edge, Delay)	DC	DC coupling.	
	AC	AC coupling. Blocks DC components from the trigger circuits.	
	HF reject	High frequency filter above 100kHz	
	LF reject	Low frequency filter below 5kHz	
Slope (Edge, Delay, Rise & Fall)	Reject noise	DC coupling with low sensitivity to reject noise.	
	  	Trigger on a rising edge. Trigger on a falling edge. Either. (either rising or falling edge)	
Trigger Level (Edge, Delay)	Level	Adjusts the trigger manually using the Trigger LEVEL knob.	
	Set to TTL 1.4V	Sets the trigger level to 1.4V, suitable for triggering on TTL signals.	
	Set to ECL -1.3V	Sets the trigger to -1.3V. This is suitable for ECL circuits.	
	Set to 50%	Sets the trigger level to 50% of the waveform amplitude.	
Holdoff	Holdoff	Sets the holdoff time.	
	Set to Minimum	Set the holdoff time to the minimum.	
Delay (Delay)	Time	Sets the delay time (10ns ~ 10s) between the trigger event and the real trigger timing.	
	Event	Sets the number of events (1 ~ 65535) passed after the trigger event, until the real trigger timing.	
	Set to Minimum	Sets the source trigger to the minimum time.	

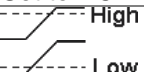
When (Pulse Width)	Sets the pulse width (10ns ~ 10s) and the triggering condition.	
	>	Longer than = Equal to
	<	Shorter than ≠ Not equal to
Threshold (Pulse Width)	Sets the amplitude threshold level for the pulse widths.	
	Threshold	-XXV ~ +XXV, user-set level
	Set to TTL	1.4V
	Set to ECL	-1.3V
	Set to 50%	Sets the threshold to 50%
Standard (Video)	NTSC	National Television System Committee
	PAL	Phase Alternate by Line
	SECAM	SEquential Couleur A Memoire
Polarity (Pulse Width, Video)		Positive polarity (triggered on the high to low transition)
		Negative polarity (triggered on the low to high transition)
Polarity (Pulse Runt)		Positive polarity (positive runt)
		Negative polarity (negative runt)
		Either (either negative or positive runt)
Trigger On (Video)	Selects the trigger point in the video signal.	
	Field	1 or 2 or all.
	Line	1~263 for NTSC 1~313 for PAL/SECAM
Threshold (Pulse Runt)		Sets the upper threshold limit. Sets the lower threshold limit.
	Set to TTL	1.4V
	Set to ECL	-1.3V
Threshold (Rise & Fall)		Sets the High threshold. Sets the Low threshold.
	Set to TTL	1.4V
	Set to ECL	-1.3V
Trigger When (Timeout)	Stays High	Triggers when the input signal stays high for a designated amount of time.
	Stays Low	Triggers when the input signal stays low for a designated amount of time.
	Either	Triggers when the input signal stays high or low for a designated amount of time.

Timer (Timeout)	10nS~10.0 S	Sets the amount of time that a signal must stay high or low for the timeout trigger.
-----------------	-------------	--

4-6-3. Setup Holdoff Level

Background The holdoff function defines the waiting period before the DCS-9700 starts triggering again after a trigger point. The holdoff function ensures a stable display if there are a number points in a periodic waveform that can be triggered. Holdoff applies to all the triggering types.

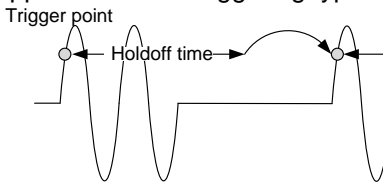

Panel Operation 1. Press the trigger *Menu* key.



2. To set the Holdoff time, press the *Holdoff* (or *Mode/Holdoff*) menu button on the bottom bezel.
3. Use the side menu to set the Holdoff time.



Range 10ns~10s

Pressing *Set to Minimum* sets the Holdoff time to the minimum, 10ns.

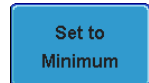



Note





Note: The holdoff function is automatically disabled when the waveform update mode is in roll mode (page88).

4-6-4. Setup Trigger Mode

Background The trigger mode can be set to Normal or Auto (untriggered roll). The triggering mode applies to all the trigger types. See page 88.

- Panel Operation**
1. Press the Trigger menu key. 
 2. Press *Mode* from the bottom menu to change the triggering mode. 
 3. Use the side panel to select *Auto* or *Normal* triggering modes.
Range Auto, Normal

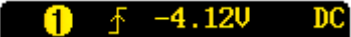
4-6-5. Using the Edge Trigger

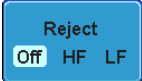
- Panel Operation**
1. Press the Trigger menu key. 
 2. Press *Type* from the lower bezel menu. 
 3. Select *Edge* from the side menu. The edge trigger indicator appears at the bottom of the display. 

From left: trigger source, slope, trigger level, coupling
 4. Press *Source* to change the trigger source. 
 5. Use the side menu to select the trigger source type.
Range Channel 1 ~ 4 (Alternate On/Off), EXT (Ext Probe: Volt/Current, Attenuation: 1mX~1kX), AC Line
 6. Press *Coupling* from the bottom bezel menu to select the trigger coupling or frequency filter settings. 
 7. Choose the coupling from the side menu.
Range DC, AC
 8. Press *Reject* to toggle the rejection filter from the side menu. 
Range HF Reject, LF Reject, Off

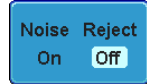
9. Toggle *Noise Rejection* On or Off from the side menu.



Range On, Off

10. From the bottom menu press *Slope* to toggle the slope type.



Range Rising edge, falling edge, either

11. To set the external trigger level, select *Level* from the bottom bezel menu.



12. Set the external trigger level using the side menu.

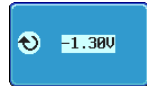

Range 00.0V~ 5 screen divisions
Set to TTL 1.4V
Set to ECL -1.3V
Set to 50%

4-6-6. Using Advanced Delay Trigger

Background The EXT trigger source is always used as the delay triggering source.

Panel Operation 1. Press the trigger *Menu* key.



2. Press *Type* from the lower bezel menu.



3. Select *Delay* from the side menu. The delay + edge trigger indicator appears at the bottom of the display.



From left: delay trigger, delay source (external), delay coupling + edge source, edge slope, edge trigger level

4. To set the delay press *Delay* from the bottom bezel.



5. To Delay by Time (duration), press *Time* from the side menu and set the delay time.



Range 10ns ~ 10s (by time)
Set to minimum

6. To Delay by Event, press *Event* from the side menu and set the number of events.

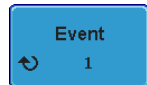

Range 1 ~ 65535 events
Set to Minimum

4-6-7. Using Pulse Width (glitch) Trigger

Panel Operation 1. Press the trigger *Menu* key.



2. Press the *Type* key from the lower bezel menu.



3. Select *Pulse Width* from the side menu. The pulse width (glitch) trigger indicator appears at the bottom of the display.



From left: source, polarity, when, coupling

4. Press *Source* from the lower bezel.

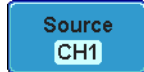

5. Use the side menu to select the pulse width (glitch) trigger source.

Range Channel 1 ~ 4 (Alternate On/Off),
EXT (Ext Probe: Volt/Current,
Attenuation: 1mX~1kX), AC Line

6. Press *Polarity* to toggle the polarity type.



Range Positive (high to low transition)
Negative (low to high transition)

7. Press *When* from the lower bezel.

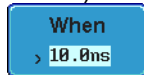

Then use the side menu to select the pulse width condition and width.

Condition > , < , = , ≠

Width 10ns ~ 10s

8. Press *Threshold* from the lower bezel to edit the pulse width threshold.



Use the side menu to set the threshold.

Range -XXV~XXV

Set to TTL 1.4V

Set to ECL -1.3V

Set to 50%

4-6-8. Using Video Trigger

Panel Operation 1. Press the *Menu* key.



2. Press the *Type* key from the lower bezel menu.



3. Select *Video* from the side menu. The video trigger indicator appears at the bottom of the display.



1 NTSC F1 1 AC

From left: source, video standard, field, line, coupling

4. Press *Source* from the lower bezel.

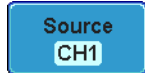

5. Use the side menu to select the video trigger source.

Range Channel 1 ~ 4

6. Press *Standard* on the bottom bezel.



Use the side menu to select the video standard.

Range NTSC, PAL, SECAM

7. Press *Trigger On* to edit the video field and line.



Use the side menu to select the field and line.

Field 1, 2, All

Video line NTSC: 1 ~ 262 (Even), 1 ~ 263

(Odd) PAL/SECAM: 1 ~ 312 (Even),

1 ~ 313 (Odd)

8. Press *Polarity* to toggle the polarity type.



Range positive, negative

4-6-9. Pulse Runt trigger

Panel Operation 1. Press the trigger *Menu* key.



2. Press the *Type* key from the lower bezel menu.



3. Select *Others* → *Pulse Runt* from the side menu. The Pulse and Runt indicator appears at the bottom of the display.

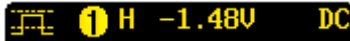

From left: Polarity, source, high/low threshold, threshold level, coupling

4. Press *Source* from the lower menu.



Use the side menu to select a source.

Range Channel 1 ~ 4

5. Press *Polarity* to toggle the polarity.

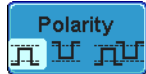

Range Rising edge, falling edge, either.

6. Press *When* from the lower menu.

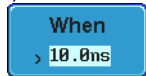

Then use the side menu to select the condition and width.

Condition > , < , = , ≠

Width 10ns ~ 10s

7. Press *Threshold* from the lower bezel to edit the threshold for the upper and lower threshold.

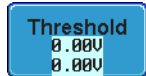

8. Use the side menu to set the upper threshold.

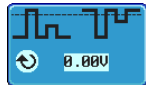

Range -XXV~XXV

Set to TTL 1.4V ,Set to ECL -1.3V

9. Use the side menu to set the lower threshold.



Range -XXV~XXV

Set to TTL 1.4V

Set to ECL -1.3V

4-6-10. Using Rise and Fall (slope) Trigger

Panel Operation 1. Press the trigger *Menu* key.



2. Press the *Type* key from the lower bezel menu.



3. Select *Others* → *Rise and Fall* from the side menu.



The Rise and Fall indicator appears at the bottom of the display.

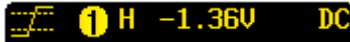

From left: Slope, source, high/low threshold, threshold level, coupling

4. Press *Source* from the lower menu.



Use the side menu to select a source.

Range Channel 1 ~ 4

5. Press *Slope* from the bottom menu to toggle the slope.



Range Rising edge, falling edge, either

6. Press *When* from the lower menu.

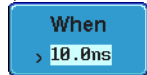

Then use the side menu to select the logic conditions and true or false status.

Condition > , < , = , ≠

Width 10ns ~ 10s

7. Press *Threshold* from the lower bezel to edit the High and Low threshold.

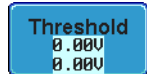

Range High: -XXV~XV

Low: -XXV~XXV

Set to TTL 1.4V

Set to ECL -1.3V

4-6-11. Using the Timeout Trigger

Panel Operation 1. Press the trigger *Menu* key.



2. Press the *Type* key from the lower bezel menu.



3. Select *Others* → *Timeout* from the side menu. The Timeout indicator appears at the bottom of the display.

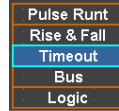

Timeout 1.40V DC

From left: Source, Trigger type, threshold level, coupling

4. Press *Source* from the lower menu.



Use the side menu to select a source.

Range Channel 1 ~ 4, D0~D15, EXT (Ext Probe: Volt/Current, Attenuation: 1mX~1kX), AC Line

5. Press *Trigger When* from the lower menu.



Then use the side menu to select trigger conditions.

Condition Stays High, Stays Low, Either

6. Press *Level* from the lower bezel to set the trigger level.



Range -XXV~XXV
Set to TTL 1.4V
Set to ECL -1.3V
Set to 50%

7. Press *Timer* from the lower bezel to set the timer time.



Range -10ns~10.0S

4-7. Search

The search feature can be used to search for events on both the analog and digital input channels. The events that can be searched for are similar to the events that are used for the trigger system. The only difference is that the search feature uses the measurement threshold levels rather than the trigger level to determine events.

4-7-1. Configuring Search Events

Background	Similar to configuring the trigger system, the Search events must first be configured before they can be found. Luckily the trigger system configuration settings can also be used for the search events. The types of searches are listed below. Please note that a full description of the events can be found in the Trigger section on page 95.
Display	Number of search events

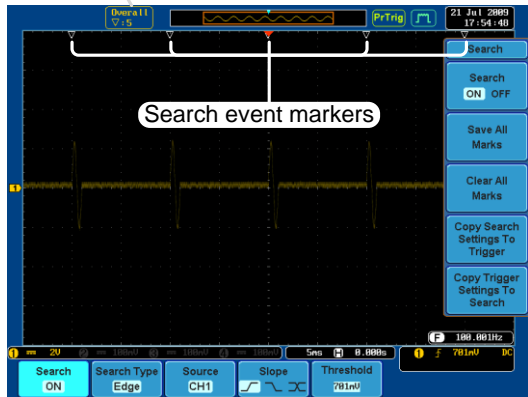

Search Event Types	Edge, Pulse Width, Pulse Runt, Rise and Fall Times, Logic*, Bus* *Requires the Logic Analyzer option.
--------------------	--

- Panel Operation
1. Press the *Search* menu key.
 2. Press *Search* from the bottom menu and turn the Search function on.



3. Press *Search Type* from the bottom menu and select the type of search. The search events are configured in the same fashion as the trigger events. Please see the trigger configuration settings for details:
 Event
 Types: Edge, Pulse Width, Pulse Runt, Rise/Fall Time, Logic*, Bus*
 *Requires the Logic Analyzer option.

Search Type
 Edge
4. To set the threshold levels for the search events (instead of the trigger level that is used for trigger events), use the threshold soft-key from the bottom menu.

Threshold
 701mV



Note

The search function can support up to 10,000 events, however only 1,000 events can be displayed on screen at once.

4-7-2. Copying Search Event To/From Trigger Events

Background As the trigger system and search feature have similar settings, their settings can be used interchangeably by using the Copy functions.

Interchangeable Settings Edge, Pulse Width, Pulse Runt, Rise and Fall Times, Logic, Bus

- Panel Operation**
1. Press *Search* from the lower bezel menu.

Search
 ON
 2. To copy settings of the selected search type to the trigger settings, select *Copy Search Settings to Trigger*.

Copy Search
 Settings To
 Trigger
 3. To copy over the current trigger settings to the search settings, press *Copy Trigger Settings to Search*.

Copy Trigger
 Settings To
 Search



Note

If the settings cannot be copied or if there are no trigger settings configured (so that you cannot copy from the trigger settings), then those particular options will not be available.

4-7-3. Search Event Navigation

Background When using the search feature, each event can be searched for according to the event settings.

Operation

1. Turn Search on and set the appropriate search type. 108
2. Search events are marked by hollow white triangles at the top of the graticule.
3. Use the search arrow keys to move between each search event.
Search events can be navigated in both stop and run mode.

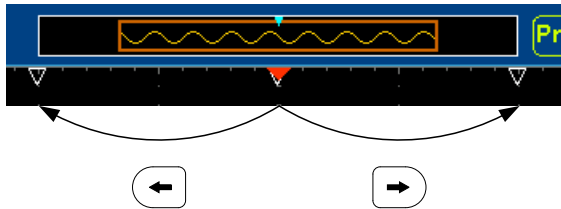

4-7-4. Save Search Marks

Background The search events can be saved to the graticule display, allowing you to superimpose new search events. Search event are saved over the entire record length, with a maximum of 200 marks.

Save Marks

1. Press *Search* from the lower bezel menu.
2. Press the *Save All Marks* soft-key.
3. The search event markers will become solid white triangles to indicate that they have been saved.



Clear All Marks To clear all the saved marks, press *Clear All Marks* from the side menu.

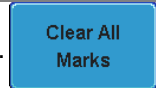





 **Note**

Each time the *Save All Marks* function is used, the previously saved marks will also be retained, unless cleared.

4-7-5. Setting/Clearing Single Search Events



Background In addition to searching for search events based on Search Type settings, custom search marks can be created with the Set/Clear key.

- Set Search Event** 1. Navigate to a point of interest using  POSITION 
the horizontal position knob or some other method.
2. Press the *Set/Clear* key. 
3. A marker will be saved at the center of the display.
- This marker can be navigated to/from in the same way that a normally saved search marker can.
-

Clear Search Event To clear a set search event, use the search arrows to navigate to the event of interest and press the  Set/Clear key.
The marker will be deleted from the display.

4-7-6. Play / Pause

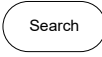
Background The Play/Pause key can be used to play through signals in Zoom mode when the Search function is turned on.

- Panel Operation** 1. Press the *Search* menu key. 
2. Setup the Search setting to the 107
3. Press the *Play/Pause* menu key. 
4. The scope will go into the Zoom Play mode and begin to scroll through the acquisition (from left to right).
The full-record length waveform will be shown in the top and the zoomed section will be shown in the bottom.

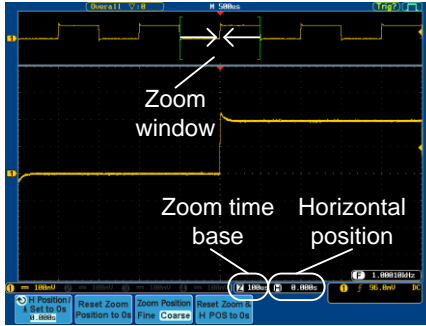

Zoom

To increase the zoom range, use the *TIME/DIV* knob.
The zoom time base (Z) at the bottom of the screen will change accordingly.

TIME/DIV

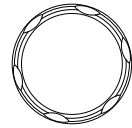

Scroll Speed

To alter the scrolling speed of the zoom window, press the *Zoom Position* key to toggle the scrolling speed.

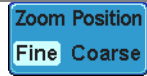

Sensitivity Fine, Coarse

Alternatively, use the Horizontal position knob to control the scroll speed.

- Turning the Horizontal knob determines the speed and direction of the scrolling.

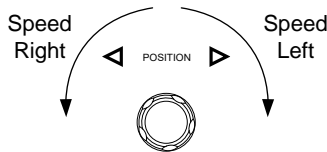

Reset the Zoom Position

To reset both the zoom position, press *Reset Position to 0s*.

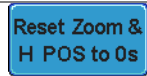

Pause

Press the *Play/Pause* key to pause or resume playing the waveform.



Reverse Direction

Press the *Play/Pause* key when at the end of the record length to play back through the waveform in reverse.



Exit

To exit, press the Zoom key.



4-8. System Info / Language / Clock

This section describes how to set the interface, beeper, language, time/date, and probe compensation signal.

4-8-1. Select Menu Language

Parameter	The following is a list of the languages available by default. Language selection may differ according to the region. <ul style="list-style-type: none">• English• Chinese (simplified)• Japanese• French• Russian• Chinese (traditional)• Korean• Polish• Spanish• German
-----------	---

Panel Operation 1. Press the *Utility* key.



2. Select the language from the side menu.



Range* English, Trad. Chinese, Simp. Chinese, Korean, Japanese, Polish, French, Spanish, Russian, German.

*Language selection may differ based on region.

4-8-2. View System Information

Panel Operation 1. Press the *Utility* key.



2. Press *System* from the lower menu.

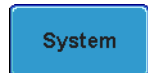

3. Press *System Info* from the side menu. A display panel will appear showing:

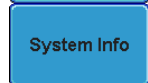

- Manufacturer name
- Model name
- Serial number
- Firmware version
- Manufacturer URL

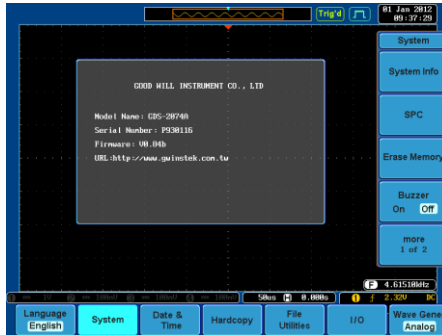

4-8-3. Erase Memory

Background	The Erase Memory function will erase all internal waveforms, setup files and labels from internal memory.
Erased Items	Waveform 1~20, Setting memory 1~20, Reference 1~4, Labels
Panel Operation	<ol style="list-style-type: none"> 1. Press the <i>Utility</i> key. 2. Press <i>System</i> from the lower menu. 3. Press <i>Erase Memory</i> from the side menu.

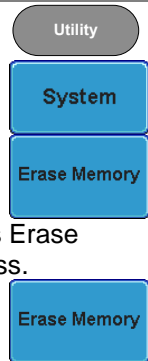

A message will prompt you to press Erase Memory again to confirm the process.

4. Press *Erase Memory* again.

4-8-4. Turn the Buzzer On/Off

- Panel Operation
1. Press the *Utility* key.
 2. Press *System* from the lower menu.
 3. Press *Buzzer* to toggle the buzzer sound on or off.

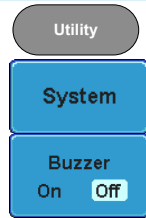

4-8-5. Set Date and Time

- Panel Operation/
Parameter
1. Press the *Utility* key.
 2. Press *Date & Time* on the lower menu.
 3. Set the *Year*, *Month*, *Day*, *Hour* and *Minute* from the side menu.
Year 2000 ~ 2037

Month 1 ~ 12
Day 1 ~ 31

Hour 1~23
Minute 0~59
 4. Press *Save Now* from the side menu to save the date and time.
 5. Make sure the date/time setting is correctly reflected at the top of the display.



4-8-6. Demo Outputs

Background

The Demo outputs on the front panel are multi-function outputs that can be configured as a probe compensation output, a trigger output signal or to output a number of waveforms for demonstration purposes.

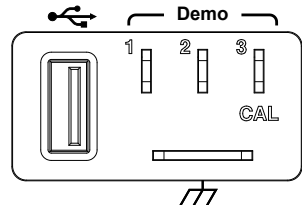

Waveforms Outputs	Mode	Demo Outputs
	Analog	Demo 1 Trigger Output OR Pulse Signal: Burst frequency: 100kHz, Burst duration: 500uS (50 pulses) Burst Period: 1mS
		Demo 2 FM: 100kHz~1MHz
		Demo 3 Probe Compensation output, 1kHz~200kHz, Duty Cycle 5%~95%
	UART	Demo 1 Tx: 115200 baud, 8 data bits, no stop bit
		Demo 2 Rx, 115200 baud, 8 data bits, no stop bit
		Demo 3 Probe Compensation output, 1kHz~200kHz, Duty Cycle 5%~95%
	I ² C	Demo 1 SCLK, 20kHz
		Demo 2 SDA, ID=0x52
		Demo 3 Probe Compensation output, 1kHz~200kHz, Duty Cycle 5%~95%
SPI	Demo 1 SCLK, 50kHz	
	Demo 2 SS	
	Demo 3 MOSI	

Panel Operation/ 1. Press the *Utility* key.

Parameter

2. Press *Demo Output* on the lower menu.

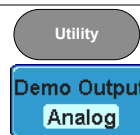

3. Press *Demo Mode* from the side menu and select the mode for the Demo outputs. The actual output waveform for each demo output is listed in the side menu.

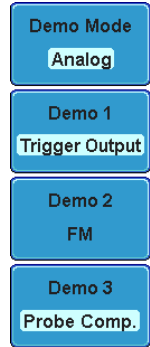

Trigger Output Usage:

To use the DEMO 1 Trigger Output signal, an input signal should first be connected to one of the input channels (CH1, 2, 3 or 4), otherwise no Trigger Output signal will be shown.

5. OPTIONAL SOFTWARE and APPS.

5-1. Applications

5-1-1. Overview

Background	The APP. function allows different applications to be run.	
Included Applications	Go/No-Go	The Go/No-Go application can be used to set threshold boundaries for input signals. Go/No-Go checks if a waveform fits inside a user-specified maximum and minimum amplitude boundary (template).

5-1-2. Running Applications

Background	The APP. function can host a number of different applications
------------	---

Panel Operation 1. Press the *Test* key.



2. Press *APP.* from the bottom menu.



3. Scroll through each application using the *Variable* knob.



4. Select an application by pressing the *Select* key *twice*.



2

5-1-3. Uninstalling Applications

Background	Any app can be easily uninstalled using the <i>Uninstall</i> function.
------------	--

Panel Operation 1. Press the *Test* key.

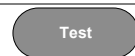

2. Press *APP* from the bottom menu.

APP.

3. Scroll through each application using the Variable knob.



4. When the desired application is highlighted, press *Uninstall* to begin the uninstallation. Press again to confirm.

Uninstall

x2

5-1-4. Using Go-NoGo

Background



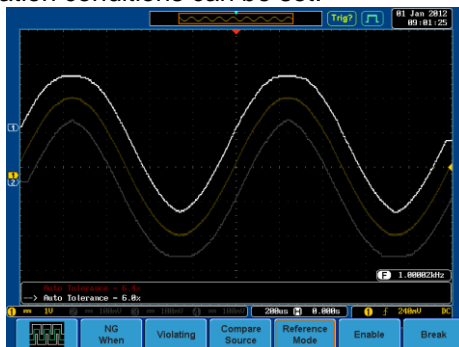



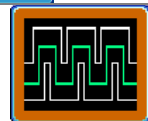

The Go-NoGo test checks if a waveform fits inside a user-specified maximum and minimum boundary. Boundary templates are automatically created from a source channel. Boundary tolerances and violation conditions can be set.

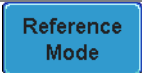

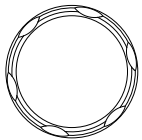
Choose the *Go_NoGo* application from the *APP*. menu. See page 118.

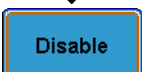

Set Go-NoGo Conditions	<p>Select the Go-NoGo conditions (NG When) and actions when a Go-NoGo condition has been met (Violating).</p>
	<p>1. Press <i>NG When</i> from the bottom menu and select the NoGo conditions:</p> <div style="display: flex; align-items: center; margin-bottom: 10px;"> <div style="border: 1px solid black; padding: 2px 10px; margin-right: 10px;">Enter</div> <p>Enters: Sets the NoGo condition to when the input signal stays within the limit boundary.</p> </div> <div style="display: flex; align-items: center; margin-bottom: 10px;"> <div style="border: 1px solid black; padding: 2px 10px; margin-right: 10px;">Exit</div> <p>Exits: Sets the NoGo condition to when the input signal exceeds the limit boundary.</p> </div> <p>2. Press <i>Go Back</i> to return to the previous menu.</p>
Set Go-NoGo Actions	<p>1. Press <i>Violating</i> to set what action to perform when a signal is violating the Go-NoGo conditions.</p>
	<div style="display: flex; align-items: center; margin-bottom: 10px;"> <div style="border: 1px solid black; padding: 2px 10px; margin-right: 10px;">Stop</div> <p>The waveform stops when the conditions are violated.</p> </div> <div style="display: flex; align-items: center; margin-bottom: 10px;"> <div style="border: 1px solid black; padding: 2px 10px; margin-right: 10px;">Stop Beep</div> <p>The waveform stops and a beep will be output when the conditions are violated.</p> </div> <div style="display: flex; align-items: center; margin-bottom: 10px;"> <div style="border: 1px solid black; padding: 2px 10px; margin-right: 10px;">Continue</div> <p>Ignore violations and continue to monitor the signal.</p> </div> <div style="display: flex; align-items: center; margin-bottom: 10px;"> <div style="border: 1px solid black; padding: 2px 10px; margin-right: 10px;">Continue Beep</div> <p>Output a beep when a violation occurs, but continue to monitor the signal.</p> </div> <p>2. Press <i>Go Back</i> to return to the previous menu.</p>
Set Go-NoGo Source	<p>1. Press <i>Compare Source</i> from the bottom menu to set the Go-NoGo boundary source.</p>
	<div style="display: flex; align-items: center; margin-bottom: 10px;"> <div style="border: 1px solid black; padding: 2px 10px; margin-right: 10px;">CH1</div> <p>Sets CH1 as the source.</p> </div> <div style="display: flex; align-items: center; margin-bottom: 10px;"> <div style="border: 1px solid black; padding: 2px 10px; margin-right: 10px;">CH2</div> <p>Sets CH2 as the source.</p> </div> <div style="display: flex; align-items: center; margin-bottom: 10px;"> <div style="border: 1px solid black; padding: 2px 10px; margin-right: 10px;">CH3</div> <p>Sets CH3 as the source.</p> </div> <div style="display: flex; align-items: center;"> <div style="border: 1px solid black; padding: 2px 10px; margin-right: 10px;">CH4</div> <p>Sets CH4 as the source.</p> </div>

	2. Press <i>Go Back</i> to return to the previous menu.	
Set Boundary Tolerance	1. To set the Go-NoGo boundary tolerance, press <i>Reference Mode</i> .	
Auto Tolerance	2. To set the boundary tolerance as a percentage offset from the source waveform, press <i>Auto Tolerance</i> and use the Variable knob.	 VARIABLE
		
Maximum and Minimum Position	Offset 0.4% ~ 40% (.4% steps) 3. To manually set the template tolerance, press <i>Minimum Position</i> or <i>Maximum Position</i> and use the Variable knob to set the absolute minimum or maximum position.	 or 
Save Boundary Template	Range Voltage division range 4. Press <i>Save Operation</i> to save the tolerance boundaries. 5. The Maximum Position tolerance will be saved to reference waveform R1, and the Minimum Position tolerance to R2. 6. Press <i>Go Back</i> to return to the previous menu.	 
 Note	It may be necessary to save a reference waveform to R1 and R2 before the tolerance for Maximum and Minimum Position can be created. This can be done by first creating and saving the Auto Tolerance boundary.	
Start Go-NoGo	Press <i>Enable</i> to start the Go-NoGo test. The Enable button will change to Disable. Pressing <i>Disable</i> will stop the Go-NoGo test and toggle the button back to Enable. If the Violating setting was set to Stop or Stop Beep, press <i>Enable</i> to restart the test after it has stopped.	 ↓ 

Results

When Go-NoGo is running, the pass/fail ratio is displayed in the bottom right-hand corner. The first digit represents the number of failed tests, and the right hand digit represents the number of tests.

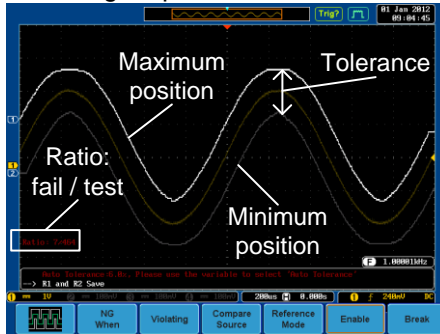

Exit the Application

To exit the application, press *Break*.

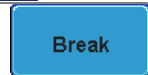

Using the Go-NoGo Output

To output the Go-NoGo results to an external device, the Go-NoGo rear panel terminal (open collector) can be used. The Go-NoGo terminal will output a positive pulse each time a NoGo violation has occurred for a minimum of 500us. The voltage of the pulse depends on the external pull-up voltage.



Timing Diagram

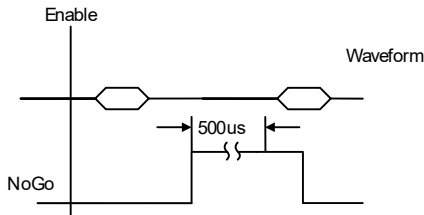

Circuit Diagram

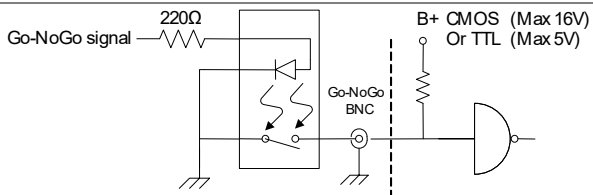

5-2. Optional Software

5-2-1. Activating Optional Software

Background The DCS-9700 has optional software packages to expand the functionality of the standard DCS-9700. An activation key is required to activate any optional software. A different activation key is required for each optional software package. For the latest files and information regarding the optional software packages, see our website or contact your nearest distributor.

Install Optional Hardware Modules Please see page 15 for details on how to install optional hardware modules if the option software also requires option hardware modules.

Install Optional Software Modules Please see page 16 for details on how to install the optional software packages.

5-2-2. Running Optional Software

Background Most of the optional software functions can be accessed via the *Option* key, located beside the bottom menu keys.

Panel Operation 1. Press the *Option* key.

Option



2. Select the relevant option from the bottom menu.

If an option is not installed, it will be grayed-out.

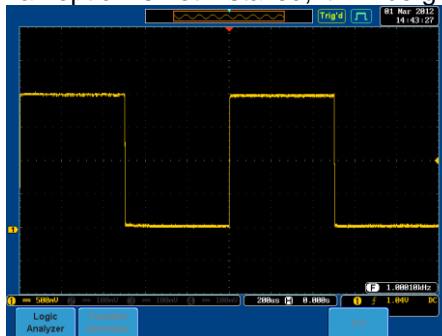

3. Please see the DCS-9700 Options User Manual for how to use the optional software functions.

5-2-3. Uninstalling Optional Software

Background Optional software packages such can be uninstalled from the system menu.

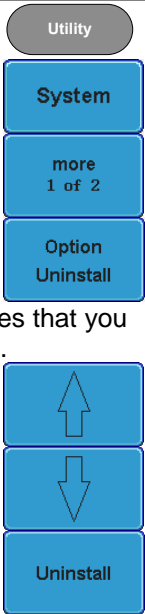
Panel Operation	<ol style="list-style-type: none">1. Press the <i>Utility</i> key.2. Press <i>System</i> from the bottom menu.3. Press <i>more 1 of 2</i> from the side menu.4. Press <i>Option Uninstall</i> on the side menu.5. Select the optional software packages that you wish to uninstall from the side menu.6. Use the <i>Up</i> and <i>Down</i> arrows on the side menu to select an option to uninstall.7. Press <i>Uninstall</i> to uninstall the option.	
------------------------	--	---

6. SAVE/RECALL

6-1. File Format/Utility

6-1-1. Image File Format

Format	DSxxxx.bmp or DSxxxx.png
Contents	The display image is 800 by 600 pixels. The background color can be inverted (Ink saver function). Each image file is saved to the current file path as a bitmap or PNG file.

6-1-2. Waveform File Format

Format	DSxxxx.lsf, CH1~CH4.lsf
	The LSF file format efficiently stores waveforms. This is the file format used for storing and recalling all waveforms that are be used with the DCS-9700 series.
Waveform Type	CH1 ~ 4 Input channel signal REF Reference waveform Math Math operation result (page 64) D0~D15 Digital channels* *For the logic analyzer options only.
Storage Location	Wave1 ~ Wave20 Waveform files stored to the internal memory. Stored waveforms can be copied to Ref. 1 ~ 4 to be viewed on the display. (W1 ~ W20 waveforms cannot be directly recalled on the display). Ref 1~4 Reference waveforms stored in the internal memory, separate from W1 ~ W20. Reference waveforms (Ref 1 ~ 4) can be displayed directly onto the display with amplitude and frequency information. Ref 1~4 are useful for reference purposes. Other waveforms (LSF and W1~20) must be recalled to R1~4 before being displayed.
Contents: Waveform Data	The waveform data can be used for detailed analysis. It consists of the horizontal and vertical data used by the waveform.

6-1-3. Spreadsheet File Format

Format	DSxxxx.csv (Comma-separated values format, can be opened in spreadsheet applications such as Microsoft Excel).
--------	--

CSV-formatted files can be stored in either a short-memory format or a long-memory format: Detail CSV, Fast CSV, LM Detail CSV and LM Fast CSV. Detail CSV will record both the horizontal and vertical sample points of the waveform. All the points are recorded in scientific notation for analog data. CSV data will only record 5000 points (10div) of data.

Fast CSV will only record the vertical amplitude of the sample points. Fast CSV also contains data that enables the horizontal data points to be reconstructed, such as trigger position, etc. Fast CSV will only record 5000 points (10div) of data. Data is recorded as integers($\pm 5\text{div}$: $\pm 125\text{pt}$).

LM Detail CSV is similar to CSV but covers the entire long-memory (See page 75 for information on the record length). All points are recorded in scientific notation for analog data.

LM Fast CSV is similar to Fast CSV but covers the entire long memory length (See page 75 for information on the record length). All points are recorded as integers.

Note, however, that only fast CSV can be recalled to the internal memory. Detailed CSV, LM Fast CSV and LM Detailed CSV cannot be recalled.

Waveform Type	CH1 ~ 4	Input channel signal
	Ref1~4	Reference waveform
	Math	Math operation result (page 64)
	D0~D15	Digital channels
	All Displayed	All the waveforms on the display.
Contents: Detail CSV & LM Detail CSV	Detail CSV waveform data contains channel information such as vertical and horizontal position of a signal for 5000 points (10div). The following information is included in Detail CSV, where applicable:	
	<ul style="list-style-type: none"> • Format (scope type) • Trigger Level • Label • Vertical units 	<ul style="list-style-type: none"> • Memory length • Source • Probe ratio • Vertical scale

- Vertical position
- Horizontal scale
- Horizontal mode
- Firmware
- Mode
- Horizontal data
- Horizontal units
- Horizontal position
- Sampling period
- Time
- Vertical data

Contents:

Fast CSV

&

LM Fast CSV

The following information is included in the Fast CSV waveform files, where applicable:

- Format (scope type)
- IntpDistance (input trigger distance)
- Trigger level
- Vertical units
- Vertical units extend div
- Probe type
- Vertical scale
- Horizontal units
- Horizontal position
- SincET mode (sampling mode)
- Horizontal old scale
- Firmware
- Mode
- Memory length
- Trigger address
- Source
- Vertical units div
- Label
- Probe ratio
- Vertical position
- Horizontal scale
- Horizontal mode
- Sampling period
- Horizontal old position
- Time
- Raw vertical waveform data

6-1-4. Setup File Format

Format	DSxxxx.set (proprietary format) The setup file saves or recalls the following settings.	
Contents	Acquire	<ul style="list-style-type: none"> • Mode • Sample rate • Digital Filter
		<ul style="list-style-type: none"> • XY • Sample mode
		<ul style="list-style-type: none"> • Record Length
	Display	<ul style="list-style-type: none"> • Mode • Persistence • Waveform intensity
		<ul style="list-style-type: none"> • Graticule intensity • Waveform visuals • Graticule
	Channel	<ul style="list-style-type: none"> • Scale • Channel • Coupling • Impedance • Invert • Bandwidth
		<ul style="list-style-type: none"> • Expand • Position • Probe • Probe attenuation • Des skew
	Cursor	<ul style="list-style-type: none"> • Horizontal cursor • H Unit
		<ul style="list-style-type: none"> • Vertical cursor • V Unit
	Measure	<ul style="list-style-type: none"> • Source • Gating • Statistics
		<ul style="list-style-type: none"> • Display • High-Low
	Horizontal	<ul style="list-style-type: none"> • Scale
Math	<ul style="list-style-type: none"> • Source1 • Operator • Source2 	
	<ul style="list-style-type: none"> • Position • Unit/Div • Math Off 	
Trigger	<ul style="list-style-type: none"> • Type • Source • Coupling • Alternate • Rejection 	
	<ul style="list-style-type: none"> • Noise Rejection • Slope • Level • Mode • Holdoff 	
Utility	<ul style="list-style-type: none"> • Language • Hardcopy key • File Format 	
	<ul style="list-style-type: none"> • Ink Saver • Buzzer • Assign Save 	
Save/ recall	<ul style="list-style-type: none"> • Image file format 	
	<ul style="list-style-type: none"> • Data file format 	

6-2. Create/Edit Labels

Overview

Reference files, Setup files and the analog input channels can have individual file labels set. For the analog channels and reference waveforms, the file label can be displayed next to the channel/reference indicator. The file labels are also obviously used to identify reference files, setup files or channels when saving or recalling waveforms and setups.

Example

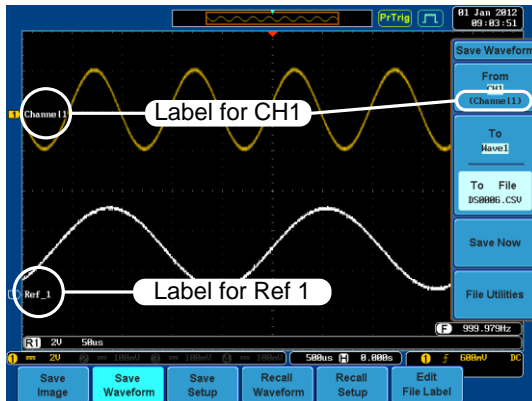

In the example above, the file label for channel 1 is displayed next to the channel indicator and is also displayed in the *Save Waveform* menu. The Ref_1 file label is shown next to the reference indicator.



Note

When using the optional Logic Analyzer, labels can also be set for the digital channels. Please see the DCS-9700 Options User Manual for details. The labels for digital channels cannot be edited from the *Save/Recall* menu.

Panel Operation

1. Press the *Save/Recall* key from the front panel.
2. Press *Edit File Label* from the bottom menu.
3. Press *Label For* and select the item that you want to create the label for.



Label For CH1~CH4, Ref1~4, Set1~20

- To choose a preset label, Press *User Preset* from the side menu and choose a label.



Labels ACK, AD0, ANALOG, BIT, CAS, CLK, CLOCK, CLR, COUNT, DATA, DTACK, ENABLE, HALT, INT, IN, IRQ, LATCH, LOAD, NMI

Edit Label

- Press *Edit Character* to edit the current label.
- The Edit Label window appears.



- Use the Variable knob to highlight a character.

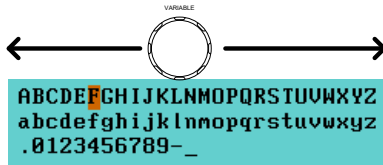

Press *Enter Character* to select a number or letter.

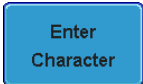

Press *Back Space* to delete a character.



Press *Editing Completed* to save the label and return to the previous menu.

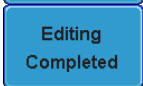

To cancel the editing the label and return to the previous menu, press *Cancel*.



Display Label

To display the currently selected file label on the screen next to its respective indicator, toggle *Label Display* to On. Conversely, if you want to remove the currently selected file label from the display, toggle *Label Display* to Off.



6-3. Save

6-3-1. File Type/Source/Destination

Item	Source	Destination
Panel Setup (DSxxxx.set)	<ul style="list-style-type: none"> • Front panel settings 	<ul style="list-style-type: none"> • Internal memory: Set1 ~ Set20 • File system: Disk, USB
Waveform Data (DSxxxx.csv) (DSxxxx.lsf) (CH1~CH4.lsf, Ref1~Ref4.lsf, Math.lsf)* ALLxxxx.csv	<ul style="list-style-type: none"> • Channel 1 ~ 4 • Math operation result • Reference waveform Ref1~4 • D0~D15¹ • All displayed waveforms 	<ul style="list-style-type: none"> • Internal memory: Reference waveform Ref1~4, Wave1 ~ Wave20 • File system: Disk, USB
Display Image (DSxxxx.bmp/png) (Axxx1.bmp/png)**	<ul style="list-style-type: none"> • Display image 	<ul style="list-style-type: none"> • File system: Disk, USB

*Stored in ALLXXX directories when All Displayed waveforms are saved.

**Stored in ALLXXX directories when the Hardcopy key is assigned to save Waveform, Setup or All.

¹Digital channels. Only applicable with the Logic Analyzer option.

6-3-2. Save Image

Images can be saved either using the Save/Recall key or by using the Hardcopy key. To save images using the Hardcopy key, see the [hardcopy section on page 147](#).

Panel Operation 1. To save to USB, connect a USB drive to the front or rear panel USB port. If a USB drive is not connected, images will be saved to the internal memory.

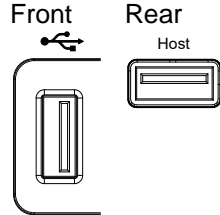

Note

Only one host connection, front or rear, is allowed at a time.

The USB Device port on the rear panel cannot be used concurrently with the USB Host port on the rear panel.

Operation

2. Press the *Save/Recall* key from the front panel.



3. Press *Save Image* from the bottom menu.



4. Press *File Format* to choose PNG or BMP file types.



Range DSxxxx.bmp, DSxxxx.png

5. Press *Ink Saver* to toggle Ink Saver On or Off.

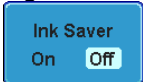

Ink Saver On

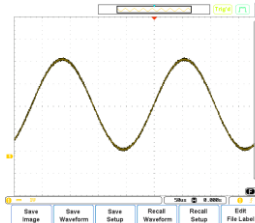

Ink Saver Off

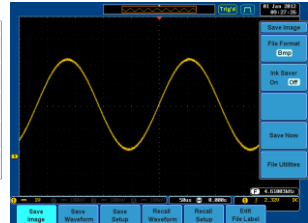

6. Press *Save Now* from the side menu to save the display as an image file.

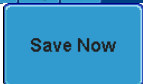

Image saved to USB : /DS0197.BMP.



Note

The file will not be saved if the power is turned off or the USB drive is taken out before the message ends.

USB File Utility

To edit the USB flash drive contents (create/ delete/ rename files and folders) or to edit the default file path, press *File Utilities* from the side menu. See page 141 for details.

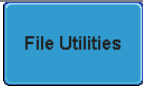

6-3-3. Save Waveform

Panel Operation

- To save to an external USB flash drive, connect the drive to the front or rear panel USB port. If a USB drive is not connected, files will be saved to the internal memory.

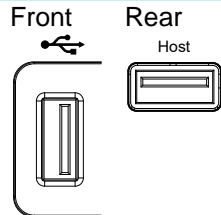

Note

Only one host connection, front or rear, is allowed at a time.

The USB Device port on the rear panel cannot be used concurrently with the USB Host port on the rear panel.

- Press the *Save/Recall* key from the front panel.
- Press *Save Waveform* from the bottom menu.
- Choose the *From* waveform on the side menu.



Source CH1~4, Math, Ref1~4,
D0~D15*, All Displayed
* digital channels only

- Press *To* (internal memory) or *To File* and choose a destination to save.



To Ref1~4, Wave1~20
To File Format: LSF, Detail CSV, Fast CSV, LM Detail CSV, LM Fast CSV

6. Press *Save Now* to confirm saving. When completed, a message appears at the bottom of the display.



Waveform saved to USB :/DS0001.CSV.

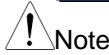

Note

The file will not be saved if the power is turned off or the USB drive is taken out before the message ends.

USB File Utility To edit USB flash drive contents (create/ delete/ rename files and folders), press *File Utilities*. For details, see page 141.



6-3-4. Save Setup

- Panel Operation**
1. (For saving to an external USB flash drive) Connect the drive to the front or rear panel USB port. If a USB drive is not connected, files will be saved to the internal memory.

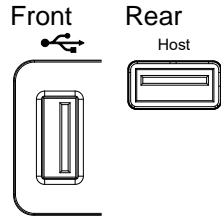

Note

Only one host connection, front or rear, is allowed at a time.

The USB Device port on the rear panel cannot be used concurrently with the USB Host port on the rear panel.

2. Press the *Save/Recall* key from the front panel.
3. Press *Save Setup* from the bottom menu.
4. Press *To* (internal memory) or *To File* and choose a destination to save.



To	Set1~Set20
To File	DSxxxx.set

5. Press *Save Now* to confirm saving. When completed, a message appears at the bottom of the display.



Setup saved to USB :/DS0001.SET.



Note

The file will not be saved if the power is turned off or the USB drive is taken out before the message ends.

USB File Utility	To edit USB flash drive contents (create/ delete/ rename files and folders) or to set the file path, press <i>File Utilities</i> . For details, see 141.	
Edit Label	To edit labels for Setup files, press <i>Edit Label</i> . For more details on editing labels, see page 129.	

6-4. Recall



6-4-1. File Type/Source/Destination

Item	Source	Destination
Default Panel Setup	<ul style="list-style-type: none"> Factory installed setting 	<ul style="list-style-type: none"> Current front panel
Reference Waveform	<ul style="list-style-type: none"> Internal memory: Ref1~4 	<ul style="list-style-type: none"> Current front panel
Panel Setup (DSxxxx.set)	<ul style="list-style-type: none"> Internal memory: S1 ~ S20 File system: Disk, USB 	<ul style="list-style-type: none"> Current front panel
Waveform Data (DSxxxx.lsf, DSxxxx.csv**) (CH1~CH4.lsf, Ref1~Ref4.lsf, Math.lsf)*	<ul style="list-style-type: none"> Internal memory: Wave 1 ~ Wave20 File system: Disk, USB 	<ul style="list-style-type: none"> Reference waveform 1 ~ 4

*Recalled from ALLXXX directories. Note that Allxxxx.csv cannot be recalled to the oscilloscope.

**Detail CSV, LM Detail CSV and LM Fast CSV files cannot be recalled to the oscilloscope.

6-4-2. Recall Default Panel Setting

Panel Operation	1. Press the <i>Default</i> key. 2. The screen will update with the default panel settings.	
Setting Contents	The following is the default (factory) setting contents.	
Acquire	Mode: Sample Sample mode: Sinc Digital filter: Off	XY: OFF Sample rate: 2GSPS Record Length: Auto
Display	Mode: Vector Waveform intensity: 50% Waveform visuals: Gray	Persistence: 16ms Graticule intensity: 50% Graticule: full 
Channel	Scale: 100mV/Div Coupling: DC Invert: Off Expand: By ground Probe: voltage Deskew: 0s	CH1: On Impedance: 1M Ω Bandwidth: full Position: 0.00V Probe attenuation: 1x
Cursor	Horizontal cursor: Off H Unit: S	Vertical Cursor: Off V Unit: Base
Measure	Source 1: CH1 Gating: Off High-Low: Auto Mean & Std: 2	Source 2: CH2 Display: Off Statistics: Off
Horizontal	Scale: 10us/Div	
Math	Source1: CH1 Source2: CH2 Unit/Div: 200mV	Operator: + Position: 0.00 Div Math Off
Test	App: Go-NoGo	
Trigger	Type: Edge Coupling: DC Rejection: Off Slope: rising Mode: Auto	Source: CH1 Alternate: Off Noise Rejection: Off Level: 0.00V Holdoff: 10.0ns
Utility	Language: English Ink Saver: Off Assign Save To: Image	Hardcopy key: Save File Format: BMP Buzzer: Off
Save / Recall	Image file format: Bmp	Data file format: LSF
Search	Search: Off	
Segments	Segments: Off	

6-4-3. Recall Waveform

- Panel Operation
1. For recalling from an external USB flash drive, connect the drive to the front or rear panel USB port.

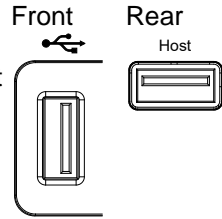

Note

Only one host connection, front or rear, is allowed at a time.

The USB Device port on the rear panel cannot be used concurrently with the USB Host port on the rear panel.

2. The waveform must be stored in advance. See page 133 for waveform store details.
3. Press the *Save/Recall* key.
4. Press *Recall Waveform* from the bottom menu. The Recall menu appears.
5. Press *From* (internal memory) or *From File* and choose a source to recall from.

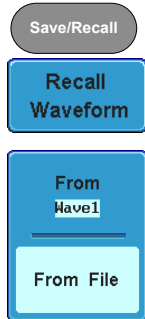

From Wave1~20

From File* File format: Lsf, Fast Csv

*Only files in the current file path will be available, this includes files saved in the ALLXXX directories.

Allxxxx.csv files cannot be recalled to the oscilloscope.

Only the “fast CSV” files can be recalled to the oscilloscope.

6. Press *To* and select the reference waveform to recall to.



To Ref1~4

7. Press *Recall Now* to recall the waveform.

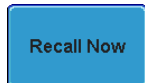

USB File Utility To edit USB flash drive contents (create/ delete/ rename files and folders) or to set the file path, press *File Utilities*. For details, see page 141.



6-4-4. Recall Setup

Panel Operation 1. (For recalling from an external USB flash drive) Connect the drive to the front or rear panel USB port.

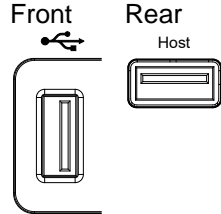

Note

Only one host connection, front or rear, is allowed at a time.
The USB Device port on the rear panel cannot be used concurrently with the USB Host port on the rear panel.

2. Press the *Save/Recall* key.
3. Press *Recall Setup* from the bottom menu.
4. Press *From* (internal memory) or *From File* and choose a source to recall from.



From Set1~20
From File DSxxx.set (USB, Disk)*
* Only files in the current file path will be available.

5. Press *Recall Now* to confirm recalling. When completed, a message appears at the bottom of the display.

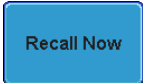

USB File Utility To edit USB flash drive contents (create/ delete/ rename files and folders) or to set the file path, press *File Utilities*. For details, see page 141.



Edit Label To edit labels for Setup files, press *Edit label*. For more details on editing labels, see page 129.





6-5. Reference Waveforms

6-5-1. Recall and Display Reference Waveforms

Panel Operation A reference waveform must be stored in advance. See page 133 to store waveforms as reference waveforms.

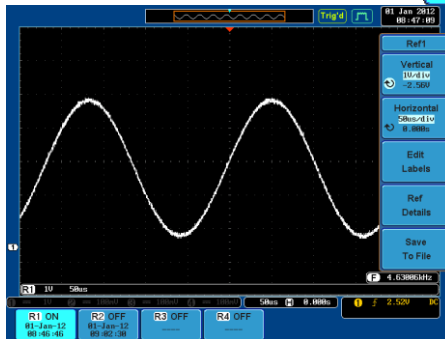
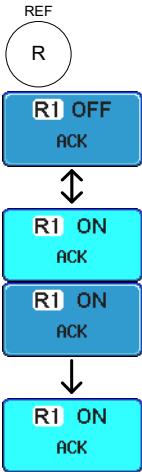
1. Press the *REF* key on the front panel.
2. Pressing *R1~R4* repeatedly will toggle the corresponding reference waveform OFF/ON.
Turning *R1~R4* ON will open the corresponding reference menu.
3. If a reference waveform is ON but not active, its reference menu can be opened by pressing the corresponding *R1~R4* key from the bottom menu.

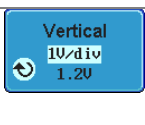
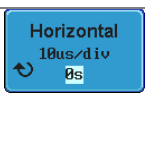
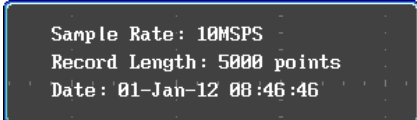
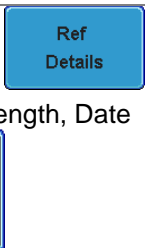

Vertical Navigation	Press <i>Vertical</i> repeatedly from the side menu to choose to edit the vertical position or Unit/Div. Use the Variable knob to edit the values.	 <p>Vertical 1V/div 1.20</p>
Horizontal Navigation	Press <i>Horizontal</i> repeatedly from the side menu to choose to edit the Time/Div or the horizontal position. Use the Variable knob to edit the value.	 <p>Horizontal 10ns/div 0s</p>
View Reference Waveform Details	<p>Pressing <i>Ref Details</i> will display the reference waveform details.</p> <p>Details: Sample Rate, Record Length, Date</p>  <p>Sample Rate: 10MSPS Record Length: 5000 points Date: 01-Jan-12 08:46:46</p>	 <p>Ref Details</p>
Edit Labels	To edit labels for Setup files, press <i>Edit Labels</i> . For more details on editing labels, see page 129.	 <p>Edit Labels</p>
Save Reference Waveforms	To save reference waveforms, press <i>Save to File</i> . For more details on saving waveforms, see page 133.	 <p>Save To File</p>

7. FILE UTILITIES

The file utilities are used each time files need to be saved to internal or external memory. The file utilities can create directories, delete directories, rename files as well as copy files from internal memory to USB. BMP and PNG image files can be previewed in the file system. The File Utilities menu also sets the file path for saving and recalling files from the Save/Recall menu.

7-1. File Navigation

The File Utilities menu can be used to choose files or to set the file path for saving/recalling files.

File System

File path

Drive space



File cursor

File attributes

Panel Operation 1. Press the *Utility* key.

2. Press *File Utilities* from the bottom menu.

3. The file system appears.

Utility

File Utilities



4. Use the *Variable* knob to move the file cursor up and down. Image files have an automatic preview. Use the *Select* key to choose a file or directory or to set the file path.

VARIABLE

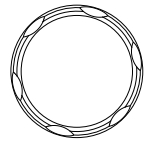

Note

- Selecting an image file will allow you to view the image at the full-screen resolution. Press the *Menu Off* key to return to the file utilities.
- When a USB flash drive is used, the file path is remembered each time the USB flash drive is used. This saves you the hassle of setting the USB file path each time the USB flash drive is inserted into the scope.

Menu Off



7-2. Create Folder

Panel Operation 1. Press the *Utility* key.

Utility

2. Press *File Utilities* from the bottom menu.
3. Use the Variable knob and select key to navigate the file system.

File Utilities

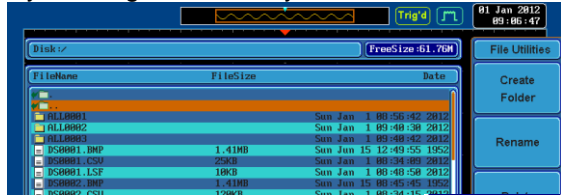

Create Folder

4. Press *Create Folder* to make a new directory at the selected location.
5. Use the *Variable* knob to highlight a character.

Create Folder

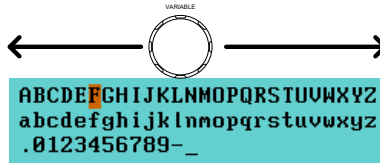

Press *Enter Character* to select a number or letter.

Enter Character

Press *Back Space* to delete a character.

Back Space

6. Press *Editing completed* to create the folder name.

Editing Completed

Cancel

Press *Cancel* to cancel the operation.

Cancel

7-3. Rename File

Panel Operation 1. Press the Utility key.

Utility

2. Press *File Utilities* from the bottom menu.

File Utilities

3. Use the Variable knob and select key to choose a file to rename.

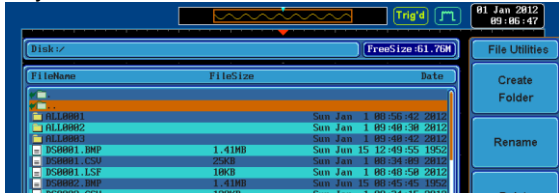

4. Press *Rename* when a file is chosen.

Rename

5. Use the *Variable* knob to highlight a character.



Press *Enter Character* select a number or letter.

Enter Character

Press *Back Space* to delete a character.

Back Space

6. Press *Editing completed* to rename the folder or file.

Editing Completed

7-4. Delete File

Panel Operation 1. Press the *Utility* key.

Utility

2. Press *File Utilities* from the bottom menu.
3. Use the Variable knob and select key to navigate the file system to choose a file.

File Utilities

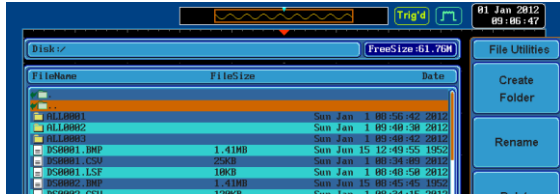

4. Press *Delete* to delete the selected file.
5. Press *Delete* again to confirm the deletion.

Delete

Delete

7-5. Copy File to USB

Panel Operation 1. Connect a USB drive to the front or rear panel USB port.

Front Rear

Host

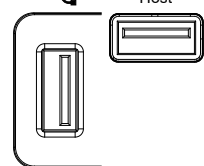

Note

Only one host connection, front or rear, is allowed at a time.

The USB Device port on the rear panel cannot be used concurrently with the USB Host port on the rear panel.

Panel Operation 2. Press the *Utility* key.

Utility

3. Press *File Utilities* from the bottom menu.
4. Use the Variable knob and select key to navigate the file system to choose a file from internal memory.

File Utilities

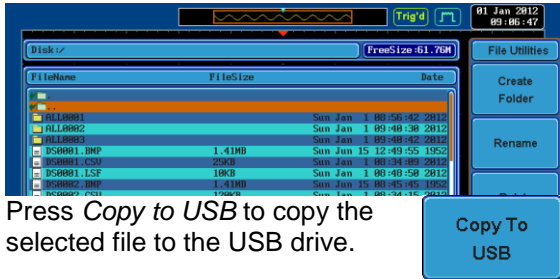

5. Press *Copy to USB* to copy the selected file to the USB drive.



If the same file name already exists on the USB drive, it will be copied over.

8. HARDCOPY KEY

The Hardcopy key is used as quick-save or quick-print key. The Hardcopy key can be assigned either to printout screenshots or to save files.

When assigned to “Print” the screen image can be printed to a PictBridge compatible printer using the USB device port. To reduce the amount of printer ink used for each print, images can be printed using the Ink Saver function.

When assigned to “Save”, pressing the Hardcopy key can be used to save a screen shot, a waveform, or the current setup, depending on the configuration.

8-1. Printer I/O Configuration

Panel Operation 1. Connect a PictBridge printer to the USB device port on the rear panel.

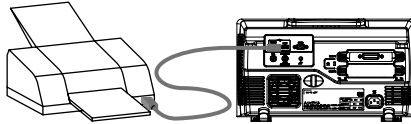

The USB Device port on the rear panel cannot be used concurrently with the USB Host port on the rear panel.

2. Press the *Utility* key.
3. Press *I/O* from the bottom menu.
4. Press *USB Device Port* from the side menu and select *Printer*.

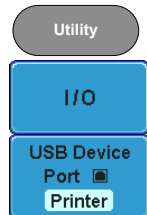

8-2. Print Output

Ensure the USB port has been configured to the printer before trying to print, see page 147.

Panel Operation 1. Press the *Utility* key.

2. Press *Hardcopy* from the bottom menu.

3. On the side menu, press *Function* and select *Print*.

4. Press the *Hardcopy* key to print.
The display image is printed out.

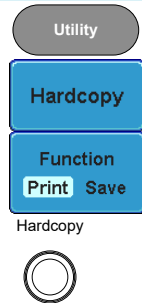

Ink Saver

To have a white background on the saved or printed display image, set *Ink Saver* to On.

Ink Saver On

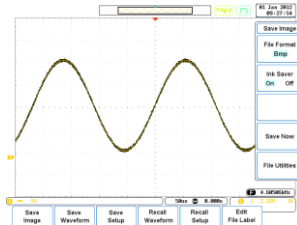

Ink Saver Off

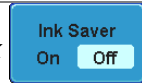
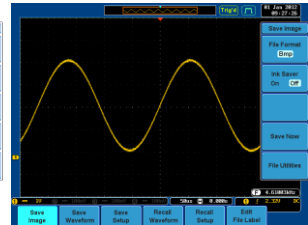

8-3. Save - Hardcopy Key

Background

When the Hardcopy key is assigned to “Save”, pressing the Hardcopy key can be used to save a screen shot, a waveform, or the current setup, depending on the configuration.

Panel Operation

1. If you wish to save to USB, connect a USB drive to the front or rear panel USB port, otherwise the file will save to internal memory.

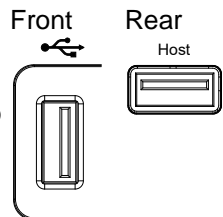

Only one host connection, front or rear, is allowed at a time. The USB Device port on the rear panel cannot be used concurrently with the USB Host port on the rear panel.

2. Press the *Utility* key.
3. Press *Hardcopy* from the bottom menu.
4. On the side menu, press *Function* to select *Save*.
5. Press *Assign Save To* and select which type of file will be saved when the *Hardcopy* key is pressed.
File Type: Image, Waveform, Setup, All
6. Press the *Hardcopy* key to save the file*.
A message will appear when the save is successful.

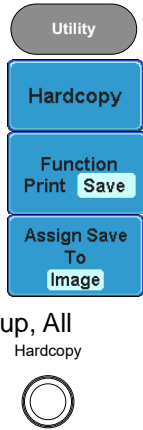

Image saved to USB : \DS0197.BMP.

Image File Format

1. For image files the file format can be selected with the *File Format* key.
Format: BMP, PNG



Ink Saver

2. To have a white background, set *Ink Saver* to On.



Ink Saver On

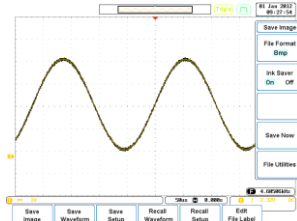

Ink Saver Off

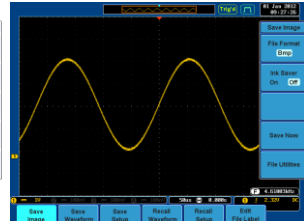

Note

*Each time the *Hardcopy* key is used to save waveforms or setup files, the files are saved into a new directory each time. The save directory is labeled ALLXXX, where XXX is incremented with each save. This directory is created in either the internal memory or to a USB flash drive.

9. REMOTE CONTROL CONFIG

This chapter describes basic configuration for remote control. For a command list, refer to the programming manual.

9-1. Configure USB Interface

USB Configuration	PC side connector	Type A, host
	DCS-9700 side connector	Type B, device
	Speed	1.1/2.0 (high speed)
	USB Class	USB-CDC
	OS	Windows7(32bit/64bit) or higher
	Driver	TEXIO_CDC.inf

Panel Operation 1. Press the Utility key.



2. Press I/O from the bottom menu.

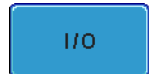

3. Press *USB Device Port* from the side menu and select *Computer*.



4. Connect the USB cable to the rear panel device port.



5. When the PC requests for the USB driver or 'Unknown device' listed in Device Manager, install TEXIO-CDC.inf attached CD.







You must have administrator account to install driver.

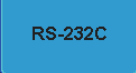
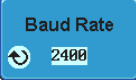

Note

9-2. Configure RS-232C Interface

RS-232C Configuration	Connector	DB-9, Male
	Baud rate	2400, 4800, 9600, 19200, 38400, 57600, 115200
	Parity	None, Odd, Even
	Data bit	8 (fixed)
	Stop bit	1, 2

Panel Operation	1. Press the <i>Utility</i> key.	
	2. Press <i>I/O</i> from the bottom menu.	
	3. Press <i>RS-232C</i> from the side menu.	
	4. Use the side menu to set the <i>Baud Rate</i> .	
	Baud Rate 2400, 4800, 9600, 19200, 38400, 57600, 115200	
	5. Press <i>Stop Bit</i> to toggle the number of stop bits.	
	Stop Bits 1, 2	
	6. Press <i>Parity</i> to toggle the parity.	
Parity Odd, Even, None		
7. Press <i>Save Now</i> to save the settings.		
8. Connect the RS-232C cable to the rear panel port: DB-9 male connector. For a functionality check, see page 156.		

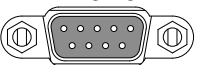
Pin Assignment	1 2 3 4 5	2: RxD (Receive data)
		3: TxD (Transmit data)
	6 7 8 9	5: GND
		4, 6 ~ 9: No connection

PC Connection Use a Null Modem connection as shown in the diagram below.

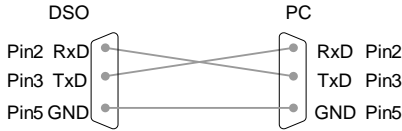

9-3. Configure the Ethernet Interface

Ethernet Configuration	MAC Address	Domain Name
	Instrument Name	DNS IP Address
	User Password	Gateway IP Address
	Instrument IP Address	Subnet Mask
		HTTP Port 80 (fixed)

 **Note** The Ethernet option, DS2-LAN, must first be installed before proceeding. Please see page 15 for further details.

Background The Ethernet interface is used for remote configuration of the oscilloscope over a network using the integrated web server or for remote control using a socket server connection. For details, the Socket Server section on page 154.

Panel Operation 1. Connect the Ethernet cable to the LAN port on the DS2-LAN module.



2. Press the *Utility* key.
3. Press *I/O* from the bottom menu.
4. Press *Ethernet* from the side menu.
5. Set *DHCP/BOOTP* to *On* or *Off* from the side menu.



 **Note** IP addresses will automatically be assigned with DHCP/BOOTP set to on. For Static IP Addresses, DHCP/BOOTP should be set to off.

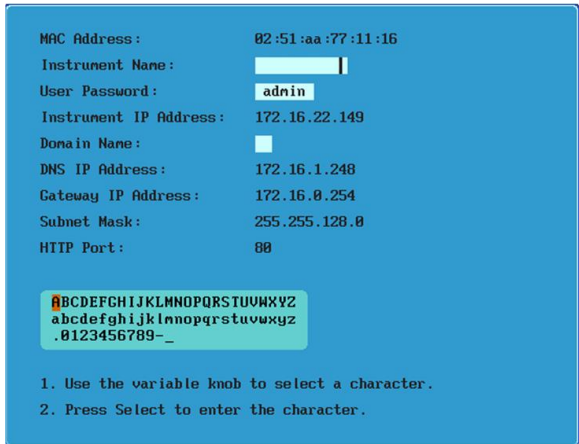

6. Use the *Up* and *Down* arrows on the side menu to navigate to each Ethernet configuration item.

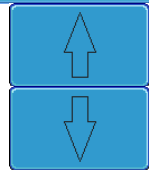

Items MAC Address, Instrument Name, User Password, Instrument IP Address, Domain Name, DNS IP Address, Gateway IP Address, Subnet Mask

Note: HTTP Port is fixed at 80.

7. Use the *Variable* knob to highlight a character and use the *Select* key to choose a character.

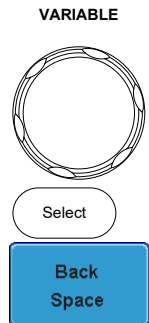

Press *Backspace* to delete a character.

9-4. Configure Socket Server

The DCS-9700 supports socket server functionality for direct two-way communication with a client PC or device over LAN. By default, the Sockets Server is off.

Configure Socket Server	1. Configure the IP address for the DCS-9700.	Page 152
-------------------------	---	----------

2. Press the <i>Utility</i> key.	
----------------------------------	---

3. Press <i>I/O</i> from the bottom menu.	
---	---

4. Press <i>Socket Server</i> from the side menu.	
---	---

5. Press <i>Select Port</i> and choose the port number with the Variable knob. Range 1024~65535	
--	---

6. Press <i>Set Port</i> to confirm the port number.	
--	---

7. The Current Port icon will update to the new port number.	
--	---

8. Press <i>Server</i> and turn the socket server On.	
---	---

9-5. Configure GP-IB



Note

To use GP-IB, the optional module, DS2-GPIB, must be installed. Please see page 15 for installation details.

Connection

1. Connect a GP-IB cable from a PC to the installed GP-IB module.

Configure GP-IB

2. Press the *Utility* key.



Utility

3. Press *I/O* from the bottom menu.



I/O

4. Use the Variable knob to set the GP-IB Address from the side menu. This option will only be available when the GP-IB module is installed.



GP-IB Address

↻ 1

Range 1 ~ 30

GP-IB

Constraints

- Maximum 15 devices altogether, 20m cable length, 2m between each device
- Unique address assigned to each device
- At least 2/3 of the devices turned On
- No loop or parallel connection

9-6. USB/RS-232C Functionality Check

Terminal Application (USB/RS-232C) Invoke a terminal application such as RealTerm or PuTTY. For RS-232C and USB, set the COM port, baud rate, stop bit, data bit, and parity accordingly. To check the COM port number and associated port settings, see the Device Manager in the PC. For Windows:

Control panel → *System* → *Hardware tab*

Example: Configuring RealTerm for RS232C communication.

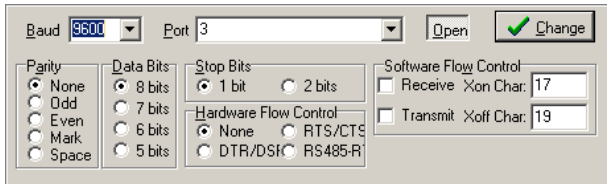

The image shows a configuration window for a terminal application. At the top, there are dropdown menus for 'Baud' (set to 9600) and 'Port' (set to 3), along with 'Open' and 'Change' buttons. Below this are several sections of radio button options: 'Parity' (None selected), 'Data Bits' (8 bits selected), 'Stop Bits' (1 bit selected), and 'Hardware Flow Control' (None selected). To the right, there are checkboxes for 'Software Flow Control' (Receive and Transmit) and two input fields for 'Xon Char' (17) and 'Xoff Char' (19).

Functionality Check

Key in this query command via the terminal application.

*idn?

This should return the Manufacturer, Model number, Serial number, and Firmware version in the following format.

TEXIO, DCS-97xx, PXXXXXX, V1.00



For further details about remote control and remote commands, please see the DCS-9700 programming manual.

9-7. Socket Server Functionality Check

NI Measurement and Automation Explorer To test the socket server functionality, National Instruments Measurement and Automation Explorer can be used. This program is available on the NI website, www.ni.com.

Operation

1. Start the NI Measurement and Automation Explorer (MAX) program. Using Windows, press: *Start>All Programs>National Instruments>Measurement & Automation*

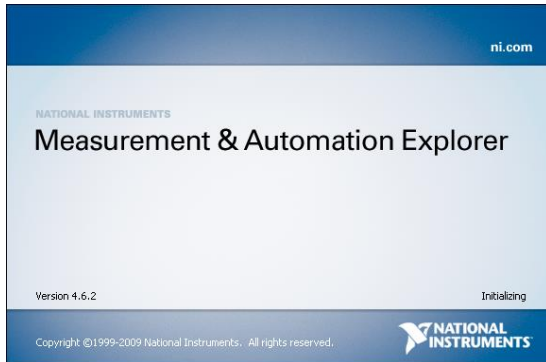

2. From the Configuration panel access; *My System>Devices and Interfaces>Network Devices*
3. Press *Add New Network Device>Visa TCP/IP Resource...*
4. Select *Auto-detect of LAN Instrument* from the popup window. The DCS-9700 should be automatically detected. If the DCS-9700 is not detected, choose the manual option.

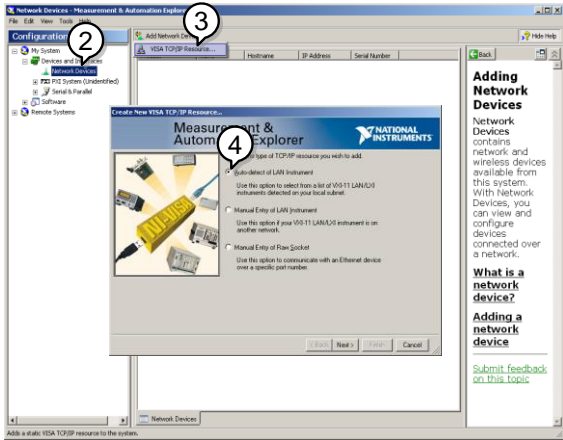

5. Select the IP address that corresponds to the DCS-9700 and click *Next*.

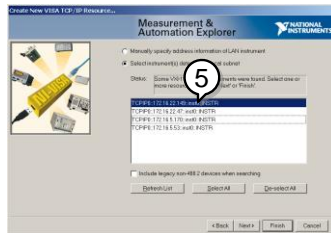

6. The DCS-9700 will now appear under Network Devices in the Configuration Panel.
7. Click the *Open Visa Test Panel* to send a remote command to the DCS-9700.

Functionality Check

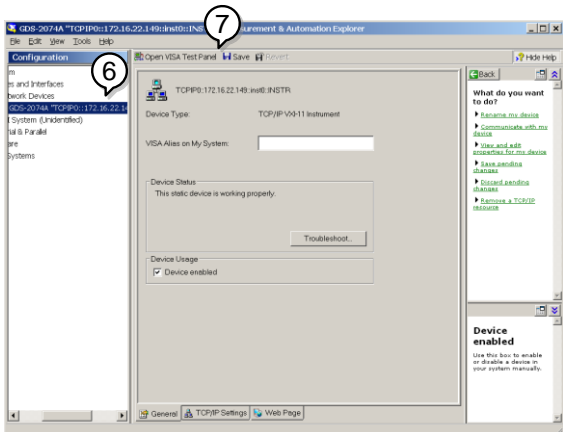

8. Click on the *viWrite* tab. The *IDN? query should already be in the buffer area.
9. Click *Execute* to execute the query.

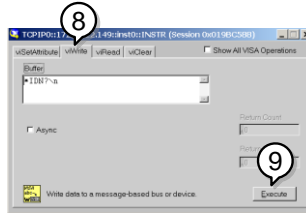

10. Click the *viRead* tab.
11. Click *Execute* to read the return parameter from the *IDN? query.
12. The manufacturer, model number, serial number and firmware version will be displayed in the buffer. For example:
TEXIO, DCS-9720, P930116, V1.00

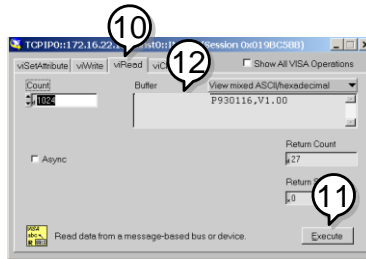

Note

For further details about remote control and remote commands, please see the DCS-9700 programming manual.

9-8. GP-IB Functionality Check

To check that the GP-IB connection is working, National Instruments Measurement & Automation Explorer (MAX) can be used. The following function check is based on version 4.6.2. For further information about National Instruments, please see the NI website at www.ni.com.

Operation

1. Start the NI Measurement and Automation Explorer (MAX) program. Using Windows, press:



Start>All Programs>National Instruments>Measurement & Automation



2. From the Configuration panel access;
My System>Devices and Interfaces>GP-IB0
3. Press the *Scan for Instruments* button.
4. In the *Connected Instruments* panel the DCS-9700 should be detected as *Instrument 0* with the address the same as that configured on the DCS-9700.
5. Double click the *Instrument 0* icon.

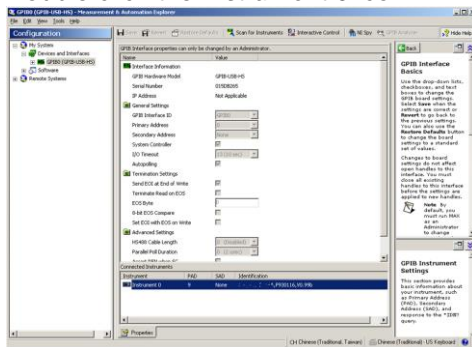

6. Click on *Communicate with Instrument*.
7. In the *NI-488.2 Communicator* window, ensure **IDN?* is written in the *Send String*: text box. Click on the *Query* button to send the **IDN?* query to the instrument.
8. The *String Received* text box will display the query return:
TEXIO, DCS-9720,PXXXXXX,V1.XX
(manufacturer, model, serial number, version)

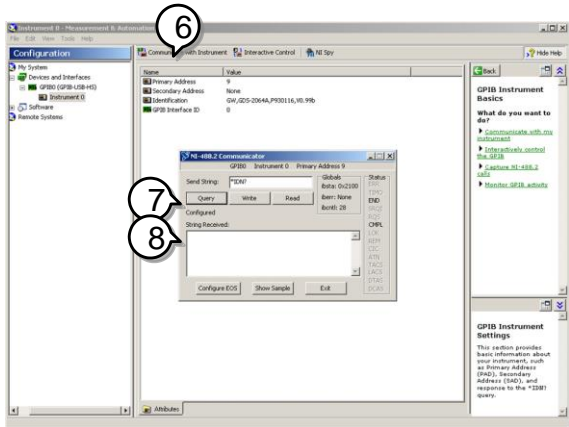

9. The function check is complete.

9-9. Web Server Overview

Background

The DCS-9700 has an inbuilt web server that can be used to:

- view the system information (Welcome Page)
- set/view the network configuration settings (Network Configuration)
- remotely view the current display image on the unit (Get Display Image)

System Information:

- Manufacturer
- Serial Number
- Firmware version
- Hostname
- Domain name
- IP Address
- Subset Mask
- DNS
- MAC Address
- DHCP State

Network Configuration

- Hostname
- Domain name
- IP Address
- Subnet mask
- Gateway
- DNS
- DHCP State

Get Display Image

- Current display image

Panel Operation 1. Configure the Ethernet interface. Page 152

2. Enter the IP address of the DCS-9700 unit into the address bar of a web browser.
For example:
`http://172.16.20.255`
3. The DCS-9700 web browser welcome page appears.

10. MAINTENANCE

Two types of maintenance operations are available: calibrate vertical accuracy, and compensate the probe. Run these operations when using the DCS-9700 in a new environment.

10-1. How to use SPC function

Background Signal Path Compensation (SPC) is used to compensate the internal signal path due to ambient temperature. SPC is able to optimize the accuracy of the oscilloscope with respect to the ambient temperature.

- Panel Operation**
1. Press the *Utility* key.
 2. Press *System* from the bottom menu.
 3. Press *SPC* from the side menu. A message showing a brief introduction to SPC appears on the screen.

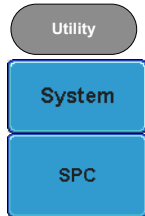

Disconnect all probes and cables from all channels before calibrating.

The DSO needs to be warmed up for at least 30 minutes before using the SPC function.

4. Press *Start* on the side menu to start SPC calibration.
5. The SPC Calibration will proceed one channel at a time, from channel 1 to channel 4.

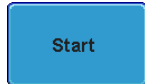

10-2. Vertical Accuracy Calibration

Panel Operation 1. Press the *Utility* key.

Utility

2. Press *System* from the bottom menu.

System

3. Press *more 1 of 2* from the side menu.

more
1 of 2

4. Press *Self Cal* on the side menu.

Self Cal

5. Press *Vertical* on the side menu.

Vertical

6. A message appears to “Now performing vertical calibration...Set CAL to the channel, then press the Vertical key”.

7. Connect the calibration signal from the rear panel to the Channel 1 input with a BNC cable.

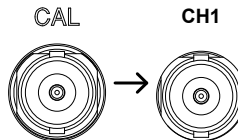

8. Press *Vertical* again after connecting CAL to the channel 1 input.

Vertical

The calibration for Channel 1 starts and ends automatically, in less than 5 minutes. A message is displayed when the calibration procedure has ended.

9. Repeat the above step for Channel 2, 3 and 4 when prompted.

10. When the calibration for all channels has completed, the display goes back to the default state.

10-3. Probe Compensation

- Panel Operation
1. Connect the probe between the Channel 1 input and the probe compensation output (Demo 3 output, by default set as 2Vp-p, 1kHz square wave) on the front panel. Set the probe attenuation to x10.
 2. Alternatively, the probe compensation signal can be changed. See page 116 for details.

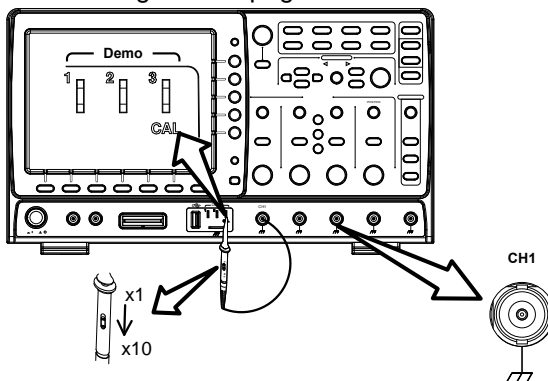

3. Press the *CH1* key to activate CH1.
4. Set the *Coupling* to DC from the bottom menu.
5. Set the Probe attenuation to *Voltage, 10X*.
6. Press the *Autoset* key. The compensation signal appears on the display.
7. Press the *Display* key, then set the display type to *Vector*.

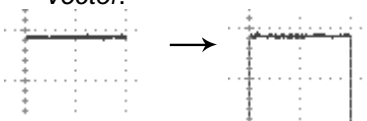
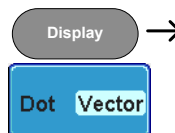
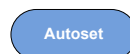
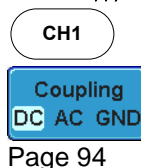

8. Turn the adjustment point on the probe to make the waveform as square as possible.

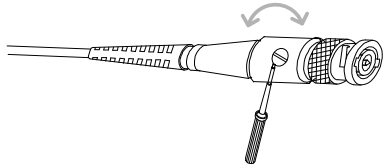
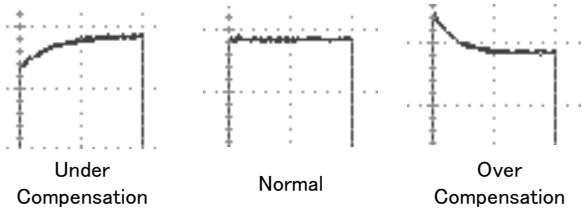

11. APPENDIX

11-1. DCS-9700 Specifications

The specifications apply when the DCS-9700 is powered on for at least 30 minutes under +20°C~+30°C.

11-1-1. Model-specific

Model	Channels	Bandwidth	Selectable Bandwidth
DCS-9707	4 + Ext	DC ~ 70MHz (-3dB)	20MHz
DCS-9710	4 + Ext	DC ~ 100MHz (-3dB)	20MHz
DCS-9720	4 + Ext	DC ~ 200MHz (-3dB)	20MHz/100MHz
DCS-9730	4 + Ext	DC ~ 300MHz (-3dB)	20MHz/100MHz/200MHz
DCS-9707D	2 + Ext	DC ~ 70MHz (-3dB)	20MHz
DCS-9710D	2 + Ext	DC ~ 100MHz (-3dB)	20MHz
DCS-9720D	2 + Ext	DC ~ 200MHz (-3dB)	20MHz/100MHz
DCS-9730D	2 + Ext	DC ~ 300MHz (-3dB)	20MHz/100MHz/200MHz

11-1-2. Common-specific

Vertical	Resolution	8 bit @1MΩ: 1mV*~10V*: When the vertical scale is set to 1mV/div, the bandwidth limit will be set to 20MHz automatically.		
	Input Coupling	AC, DC, GND		
	Input Impedance	1MΩ // 16pF		
	DC Gain	±5% Full scale when 1mV/div is selected		
	Accuracy*	±3% Full scale when 2mV/div or greater is selected		
	Polarity	Normal & Invert		
	Maximum Input Voltage	300V (DC+AC Peak), CAT I		
	Offset Position	1mV/div	~	20mV/div : ±0.5V
	Range	50mV/div	~	200mV/div : ±5V
		500mV/div	~	2V/div : ±25V
		5V/div	~	10V/div : ±250V
	Waveform	+, -, x, ÷, FFT, FFTrms, d/dt, ∫dt, √		
	Signal Process	FFT:Spectral magnitude. Set FFT Vertical Scale to Linear RMS or dBV RMS, and FFT Window to Rectangular, Hamming, Hanning, or Blackman-Harris.		

Trigger	Source	CH1 ,CH2, CH3, CH4, Line, EXT, D0-D15		
	Trigger Mode	Auto (supports Roll Mode for 100 ms/div and slower), Normal, Single		
	Trigger Type	Edge, Pulse Width(glitch), Video, Pulse Runt, Rise & Fall(slope), Timeout, Alternate, Event-Delay(1~65535 events), Time-Delay(duration,10nS~10S), Logic*, Bus**with Logic Analyzer Option		
	Holdoff range	10nS to 10S		
	Coupling	AC,DC,LF rej. ,Hf rej. ,Noise rej.		
	Sensitivity	DC	~ 100MHz	Approx. 1div or 1.0mV
		100MHz ~ 200MHz		Approx. 1.5div or 15mV
200MHz ~ 300MHz			Approx. 2div or 20mV	
External Trigger	Range	±15V		
	Sensitivity	DC	~ 100MHz	Approx. 100mV
		100MHz ~ 200MHz		Approx. 150mV
		200MHz ~ 300MHz		Approx. 150mV
Input Impedance	1MΩ// 16pF			
Horizontal	Time base	1ns/div ~ 100s/div (1-2-5 increments)		
	Range	ROLL: 100ms/div ~ 100s/div		
	Pre-trigger	10 div maximum		
	Post-trigger	1000 div maximum.		
	Accuracy	±20 ppm over any ≥ 1 ms time interval		
	Real Time	1CH: 2GSa/s		
	Sample Rate	2CH: 1GSa/s		
	ET Sample Rate	100GSa/s maximum		
	Record Length	1CH: 2Mpts(10div) 2CH: 1Mpts(10div)		
	Acquisition Mode	Normal, Average, Peak Detect, Single		
	Peak (glitch) Detection	2nS (typical)		
	Average	selectable from 2 to 256		
X-Y Mode	X-Axis Input	Channel 1; Channel 3*		
	Y-Axis Input	Channel 2; Channel 4*		
	Phase Shift	±3° at 100kHz		
Cursors and	Cursors	Amplitude, Time, Gating available		

Measurement	Automatic Measurement	36 sets: Pk-Pk, Max, Min, Amplitude, High, Low, Mean, Cycle Mean, RMS, Cycle RMS, Area, Cycle Area, ROVShoot, FOVShoot, RPREShoot, FPREShoot, Frequency, Period, RiseTime, FallTime, +Width, -Width, Duty Cycle, +Pulses, -Pulses, +Edges, -Edges, FRR, FRF, FFR, FFF, LRR, LRF, LFR, LFF, Phase
	Cursors measurement	Voltage difference between cursors (ΔV) Time difference between cursors (ΔT)
	Auto counter	6 digits, range from 2Hz minimum to the rated bandwidth
Control Panel Function	Autoset	Single-button, automatic setup of all channels for vertical, horizontal and trigger systems, with undo Autoset
	Save Setup	20set
	Save Waveform	24set
Display	TFT LCD Type	8" TFT LCD SVGA color display
	Display Resolution	800 horizontal x 600 vertical pixels (SVGA)
	Interpolation	Sin(x)/x & Equivalent Time Sampling
	Waveform Display	Dots, vectors, variable persistence (16ms~10s), infinite persistence
	Waveform Update Rate	80,000 waveforms per second, maximum
Interface	Display Graticule	8 x 10 divisions
	RS232C	D-sub 9 male connector X1
	USB Port	USB 2.0 host port x 2, USB 2.0 device port x 1:full speed,CDC-ACM
	Ethernet Port (option)	RJ-45 connector, IEEE802.3 10/100Mbps with Auto-MDIX
	Go-NoGo BNC	5V Max/10mA TTL open collector output
	SVGA Video (option)	SVGA output ,D-sub 15 female connector
	GP-IB (option)	GP-IB module,IEEE488.2Compatible
	Kensington Style Lock	Rear-panel security slot connects to standard Kensington-style lock.
Logic Analyzer (Option)	Sample Rate	500MSa/s
	Bandwidth	200MHz
	Record Length	2M max/ch
	Input Channels	16 Digital (D15 - D0) or 8 Digital (D7~D0)
	Trigger type	Edge, Pattern, Pulse Width, Serial bus (I2C, SPI, UART)
	Thresholds	Quad-D0~D3, D4~D7. . . . Thresholds

	Threshold selections	TTL, CMOS, ECL, PECL, User Defined
	User-defined Threshold Range	±10V
	Maximum Input Voltage	±40V
	Minimum Voltage Swing	±500mV
	Vertical Resolution	1 bit
Miscellaneous	Multi-language menu	Available
	On-line help	Available
	Time clock	Time and Date ,Provide the Date/Time for saved data
	Dimensions	380mmX220mmX145mm
Power Source	Weight	4.2kg
	Line Voltage	100V~240V AC, 50Hz~60Hz
	Power Consumption	55W 80VA (Typ.)
Accessory	AC Power cord	x1
	Probe (See Probe Specifications)	x4 or x2
	ACCESSORY CD-ROM	x1
	USING THE PRODUCT SAFTY	x1
Options	DS2-LAN	Ethernet & SVGA output
	DS2-GPIB	GP-IB Interface
	DS2-FGN	DDS Function Generator
	DS2-08LA	8-Channel Logic Analyzer with 8-channel Logic Analyzer Testing Probe
	DS2-16LA	16-Channel Logic Analyzer with 16-channel Logic Analyzer Testing Probe

11-2. Probe Specifications

11-2-1. GTP-070B-4

Applicable to: DCS-9707/DCS-9707D

Position X10	Attenuation Ratio	10:1
	Bandwidth	DC to 70MHz
	Input Resistance	10M Ω when used with oscilloscopes with 1M Ω input.
	Input Capacitance	14.5pF to 17.5pF
	Compensation Range	10pF to 35pF
Position X1	Max. Input Voltage	\leq 600Vpk, Derating with frequency
	Attenuation Ratio	1:1
	Bandwidth	DC to 10MHz
	Input Resistance	1M Ω when used with 1M Ω input
	Input Capacitance	85pF to 115pF
Operating Cond.	Max. Input Voltage	\leq 200Vpk, Derating with frequency
	Temperature	-10°C to 50°C
	Relative Humidity	\leq 85%

11-2-2. GTP-150B-4

Applicable to: DCS-9710/DCS-9710D

Position X10	Attenuation Ratio	10:1
	Bandwidth	DC to 150MHz
	Input Resistance	10M Ω when used with oscilloscopes with 1M Ω input.
	Input Capacitance	14.5pF to 17.5pF
	Compensation Range	5pF to 30pF
Position X1	Max. Input Voltage	\leq 600Vpk, Derating with frequency
	Attenuation Ratio	1:1
	Bandwidth	DC to 10MHz
	Input Resistance	1M Ω when used with 1M Ω input
	Input Capacitance	85pF to 115pF
Operating Cond.	Max. Input Voltage	\leq 200Vpk, Derating with frequency
	Temperature	-10°C to 50°C
	Relative Humidity	\leq 85%

11-2-3. GTP-250A-2

Applicable to: DCS-9720/DCS-9720D

Position X10	Attenuation Ratio	10:1
	Bandwidth	DC to 250MHz
	Rise Time	1.4nS
	Input Resistance	10M Ω when used with oscilloscopes with 1M Ω input.
	Input Capacitance	Approximately 17pF
	Compensation	10pF to 35pF
	Range	
Max. Input Voltage	500V CAT I, 300V CAT II (DC + peak AC) derating with frequency.	
Position X1	Attenuation Ratio	1:1
	Bandwidth	DC to 6MHz
	Rise Time	58nS
	Input Resistance	1M Ω (Oscilloscope Input)
	Input Capacitance	47pF plus oscilloscope capacitance
	Max. Input Voltage	300V CAT I, 150V CAT II (DC + peak AC) derating with frequency.
Safety	EN61010-031 CAT II	

11-2-4. GTP-350A-2

Applicable to: DCS-9730/DCS-9730D

Position X10	Attenuation Ratio	10:1
	Bandwidth	DC to 350MHz
	Rise Time	1.0nS
	Input Resistance	10M Ω when used with oscilloscopes with 1M Ω input.
	Input Capacitance	Approximately 13pF
	Compensation	10pF to 25pF
	Range	
Max. Input Voltage	500V CAT I, 300V CAT II (DC + peak AC) derating with frequency.	
Position X1	Attenuation Ratio	1:1
	Bandwidth	DC to 6MHz
	Rise Time	58nS
	Input Resistance	1M Ω (Oscilloscope Input)
	Input Capacitance	46pF plus oscilloscope capacitance
	Max. Input Voltage	300V CAT I, 150V CAT II (DC + peak AC) derating with frequency.
Safety	EN61010-031 CAT II	

11-3. DCS-9700 Dimensions

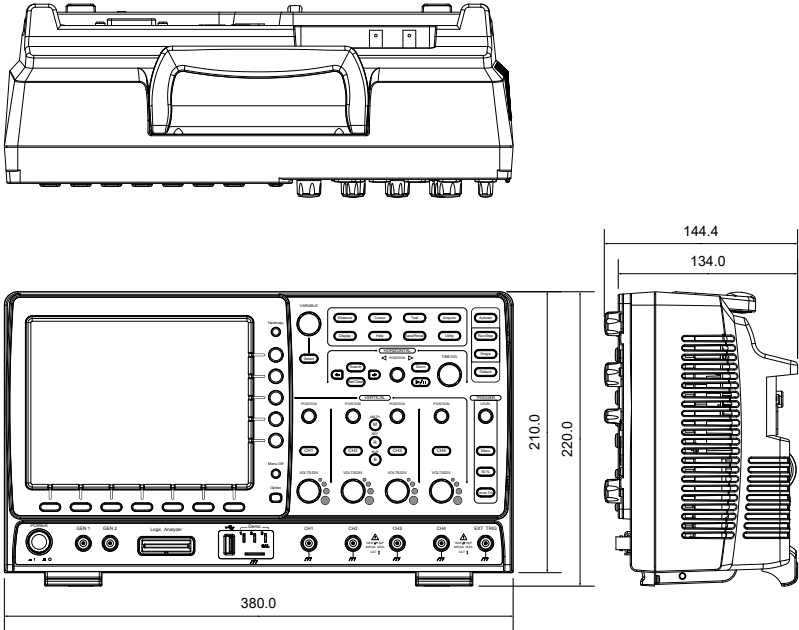

11-4. FAQ

- I connected the signal but it does not appear on the display.
- I want to remove the (Measurement result / FFT result / Help contents) from the display.
- The waveform does not update (frozen).
- The probe waveform is distorted.
- Autoset does not catch the signal well.
- I can't save files to the internal memory.
- The display image printout is too dark on the background.
- The date and time settings are not correct.
- The accuracy does not match the specification.

- **I connected the signal but it does not appear on the display.**
Make sure you have activated the channel by pressing the Channel key (the channel key lights up).

- **I want to remove the (Measurement result / FFT result / Help contents) from the display.**
To clear automatic measurement results, press the Measure key, select Remove Measurement and choose Remove All. See page 54.
To clear individual measurements from the screen, press the Measure key, select Display All and choose Off. See page 55.
To clear the FFT result, press the Math key twice. See page 64 for details.
To clear Help result, press the Help key again. See page 43 for details.

- **The waveform does not update (frozen).**
Press the Run/Stop key to unfreeze the waveform. See page 46 for details.
If this does not help, the trigger mode might be set to Single.
Press the Single key to exit Single mode. See page 46 for Single trigger details.

- **The probe waveform is distorted.**
You might need to compensate the probe.

- **Autoset does not catch the signal well.**
The Autoset function cannot catch signals under 30mV or 20Hz. Please use the manual operation. See page 45 for Autoset details.
- **I can't save files to the internal memory.**
If a USB stick is inserted into one of the USB slots and you wish to save to the scope internal memory, press the Utilities key and set the file path to internal memory.
- **The display image printout is too dark on the background.**
Use the Ink Saver function which reverses the background color. For details, see page 148.
- **The date and time settings are not correct.**
For date and time setting details, please see page 115. If it does not help, the internal battery controlling the clock might be worn out. Contact your dealer.
- **The accuracy does not match the specification.**
Make sure the device is powered On for at least 30 minutes, within +20°C~+30°C. This is necessary to stabilize the unit to match the specification.

For more information, contact your local dealer or TEXIO TECHNOLOGY at www.texio.co.jp / info@texio.co.jp.



TEXIO TECHNOLOGY CORPORATION

7F Towa Fudosan Shin Yokohama Bldg., 2-18-13, Shin Yokohama, Kohoku-ku,
Yokohama, Kanagawa, 222-0033, Japan.

<http://www.texio.co.jp/>
