

# INSTRUCTION MANUAL

## REGULATED DC POWER SUPPLY PSF SERIES

PSF-400H

PSF-800H



## ■ About Brands and Trademarks

Our company and product names described in this manual are the brands and trademarks owned by the respective companies or organizations in each country and region.

## ■ About the Instruction Manual

Permission from the copyright holder is needed to reprint the contents of this manual, in whole or in part. Be aware that the product specifications and the contents of this manual are subject to change for the purpose of improvement. The latest version of the instruction manual is posted on our website (<https://www.texio.co.jp/download/>).

In order to be environmentally friendly and reduce waste, we are gradually discontinuing the use of paper or CD manuals that come with our products.

Even if there is a description in the instruction manual that the product is included, it may not be included.

# CONTENTS

USING THE PRODUCT SAFELY .....	I - IV
<b>1. GENERAL .....</b>	<b>1</b>
1-1. General .....	1
1-2. Applicable Products .....	1
1-3. Features.....	1
1-4. Accessories.....	3
<b>2. SPECIFICATIONS .....</b>	<b>4</b>
<b>3 PRELIMINARY INSTRUCTIONS .....</b>	<b>11</b>
<b>4. DEVICES ON PANELS .....</b>	<b>13</b>
4-1. Front Panel .....	13
4-2. Operation Panel.....	14
4-3. Rear Panel.....	17
<b>5. OPERATION PROCEDURES .....</b>	<b>20</b>
5-1. Connecting AC Power Cable .....	20
5-2. Connecting Load with Output Terminals .....	20
5-2-1. Connection with the rear output terminals.....	20
5-2-2. Assembling and connecting the front output terminal plug .....	22
5-3. Operation Ranges.....	23
5-4. Various Setting.....	24
5-4-1. How to rotate display panel by 90 degrees .....	24
5-4-2. Various Setting .....	24
5-4-3. How to set voltage.....	25
5-4-4. How to set current .....	25
5-4-5. How to set power .....	25
5-4-6. How to output.....	26
5-4-7. How to display the set value in outputting condition .....	27
5-4-8. How to invalidate on-panel operations (Key lock function).....	27
5-5. Various Functions Available on Menus .....	28
5-5-1. Preset function (01).....	29
5-5-2. OVP/OCP function (02) .....	30
5-5-3. OFF timer function (03) .....	31
5-5-4. Sequence function (04) .....	32

5-5-5. External control (external voltage, external resistance) (05) .....	35
5-5-6. External control (ON/OFF) (06) .....	37
5-5-7. Master-slave function (10).....	38
5-6. Output Voltage Remote Sensing .....	39
5-7. External Control Functions .....	40
5-7-1. Output voltage monitor and output current monitor .....	41
5-7-2. Set voltage with external voltage or resistance.....	42
5-7-3. Set current with external voltage or resistance .....	43
5-7-4. Output ON/OFF with external contacts.....	44
5-7-5. Alarm function using external contacts.....	44
5-7-6. Various status signals (CV, CC & ALARM) .....	45
5-8. Activating output when turning on power .....	46
5-9. Usage of sequence Function .....	46
<b>6. OTHER FUNCTIONS</b> .....	<b>48</b>
6-1. Display in alarm status.....	48
6-2. One-Control Parallel Operation .....	49
<b>7. OPTION</b> .....	<b>53</b>
7-1. Accessories.....	53
7-2. Interface Boards .....	53
<b>8. EXTERNAL CONTROL THROUGH INTERFACE BOARD</b> .....	<b>54</b>
8-1. Remote control .....	54
8-2. Interface connectors .....	54
8-3. Specifications .....	55
8-3-1. Specifications of IF-60RU .....	55
8-3-2. Specifications of IF-60GP .....	56
8-4. Connection Methods.....	57
8-5. Connection cable .....	58
8-6. Address Setting.....	58
8-7. Using Interface Boards .....	61
8-7-1. Using the GP-IB interface .....	61
8-7-2. Using the USB interface.....	61
8-7-3. Using the RS-232C interface .....	62
8-7-4. Using the local bus.....	62
8-8. Communication commands .....	62
8-8-1. Output voltage setting (: VOLT) .....	64

8-8-2. OVP setting (: VOLT: PROT) .....	64
8-8-3. Output current setting (: CURRE) .....	64
8-8-4. OCP setting (: CURRE: PROT).....	65
8-8-5. Output power setting (: POW) .....	65
8-8-6. OUTPUT ON/OFF (:OUTP).....	66
8-8-7. Display switching (:CONF:DISP).....	66
8-8-8. External control setting (:EXT:MOD) .....	66
8-8-9. External output voltage controlON/OFF (:EXT:VOLT) .....	67
8-8-10. External output current control ON/OFF (:EXT:CURRE) .....	67
8-8-11. OUTPUT switching (:EXT:OUTP) .....	67
8-8-12. Off timer ON/OFF (:TIMER:MOD).....	68
8-8-13. Off timer value setting (:TIMER:SET).....	68
8-8-14. Monitor inquiry (:MEAS?) .....	68
8-8-15. Preset calling (:PRES:CALL).....	69
8-8-16. Preset saving (:PRES:SAVE) .....	69
8-8-17. Sequence mode setting (:SEQ:MOD) .....	69
8-8-18. Sequence jump setting (:SEQ:STEP) .....	70
8-8-19. Sequence start step setting (:SEQ:START) .....	70
8-8-20. Sequence end step setting (:SEQ:END) .....	70
8-8-21. Sequence repetition number setting (:SEQ:CYCL) .....	71
8-8-22. Sequence data transfer (:SEQ:DOWNLOAD) .....	71
8-8-23. Model inquiry ( * IDN ? ) .....	71
8-8-24. Event register inquiry ( * ESR? ) .....	72
8-8-25. Event enable register setting ( * ESE).....	72
8-8-26. Status byte inquiry ( * STB? ) .....	72
8-8-27. SRQ enable register setting ( * SRE).....	72
8-8-28. Buffer clear ( * CLS).....	72
8-8-29. Communication reset ( * RST) .....	72
8-8-30. Command completion ( * OPC).....	73
8-8-31. Wait for completion ( * WAI).....	73
8-8-32. Local address setting (:ADDR).....	73
8-8-33. Remote/local setting (:REMOTE) .....	74
8-9. Registers.....	75
8-9-1. Status register (STB、SRE) .....	76

8-9-2. Event register (ESR, ESE).....	77
8-9-3. Function of the status byte .....	78
8-9-4. Reading data from the status byte and clearing the status byte .....	78
8-9-5. Clear and reset statuses .....	79
8-9-6. Remote/local function.....	80
8-9-7. Responses to multi-line message commands .....	80
<b>9. TROUBLESHOOTING</b> .....	<b>81</b>
<b>10. MAINTENANCE</b> .....	<b>82</b>
<b>11. OUTSIDE DIMENSIONS</b> .....	<b>83</b>

---

---

## USING THE PRODUCT SAFELY

---

---

### ■ Preface

To use the product safely, read this instruction manual to the end. Make sure you understand how to correctly use this product before using it.



If you read this manual but you do not understand how to use the product, call our company or one of our service centers.

Save the instruction manual after you read it so that you can refer to it when necessary.

### ■ Pictorial indication and warning character indication

This instruction manual and the product show the warning and caution items required to safely use the product.

The following pictorial indication and warning character indication are provided.

<Pictorial indication>	
	<p>Some parts of this product or certain sections of the instruction manual may show this pictorial indication. In this case, if that part of the product is used incorrectly, the user's body or the product may be exposed to serious danger.</p> <p>Be sure to refer to this instruction manual when using parts with this pictorial indication.</p>
 	<p>If you ignore this indication and incorrectly use the product, you may be killed or seriously injured. This indication means that a warning item is provided in order to avoid extreme risk.</p> <p>If you ignore this indication and incorrectly use the product, you may suffer slight injury or the product may be damaged. This indication means that a caution item is provided in order to avoid risk.</p>

Our company will assume no responsibility for any damage resulting from the misuse of the product by the user or a third party, a failure or other trouble that occurs during operation, or the general use of the product, except for cases where our company is legally liable for the damage

---

---

## USING THE PRODUCT SAFELY

---

---



### ■ Do not remove the product's covers and panels

Never remove the product's covers and panels for any purpose. Doing so may expose the user to electric shock, or result in a fire.

### ■ Caution on using the product

The warning items below are given to avoid danger to the user's body and life, and to prevent the damage and deterioration of the product.

Observe the following warning and caution items as you use the product.

### ■ Warning items on power supply

#### ● Power supply voltage

The applicable rated source voltage for this product is from 100VAC to 240VAC or 230VAC.

For the rated voltage of each respective product, see the indication on the rear panel of the product or the "SPECIFICATIONS" in this instruction manual. Products for Japan and for regions of commercial power supply voltage up to 125VAC are supplied with a 125VAC rated power cable. However, this cable may need to be replaced with a different AC power cable when using the product on source voltage over 125VAC. Using the product on a high voltage that exceeds 125VAC without replacing the power cable may result in electric shock or fire. For products that can switch between source-voltages, see the chapter about switching the source voltage in the instruction manual included with each respective product for details.

#### ● Power cable

**Important: The attached power cable can only be used for this product.**

If the attached power cable is damaged, stop using it immediately and contact our company or one of our service centers. Continuing to use the damaged power cable may result in electric shock or fire.

#### ● Protection fuse

If the input protection fuse is blown, the product will not operate. For products equipped with an external fuse holder, the fuse can be replaced. See the section about fuse replacement in this manual for details.

If no means of replacing the fuse is available to the user, it cannot be replaced. If the fuse is blown, do not open the case. Contact our company or one of our service centers and request to have the fuse replaced by one of our representatives. Incorrectly replacing the fuse may result in electric shock or fire.



---

---

## USING THE PRODUCT SAFELY

---

---

### ■ Warning about grounding

If the product is equipped with a GND terminal on the front or rear panel, be sure to connect a ground wire to the GND terminal to ensure safe operation.

### ■ Warning about installation conditions

#### ● Operating Temperature and Humidity

Use the product within the operating temperature range described in the "SPECIFICATIONS". Do not use the product with the vent holes blocked or in a high ambient temperature. Failure to heed this warning may result in fire.

Use the product within the operating humidity range described in the "SPECIFICATIONS". When moving the product to a room with a different humidity, pay attention to dew condensation caused by a sudden humidity. Also, do not handle or operate the product with wet hands. Failure to heed to this warning may result in electric shock or fire.

#### ● Using Product Near Gases

Do not use the product in or around a place where combustible gas, explosive gas, or vapor is produced or stored. Failure to heed this warning may result in explosion or fire.

Do not use the product in or around a place where corrosive gas is produced or accumulated. Failure to heed this warning may result in serious damage to the product.

#### ● Installation Place

Do not install the product on an inclined surface or in a place subject to vibration. Otherwise, the product may fall down or tip over, resulting in damage or an injury

### ■ Do not allow foreign objects to enter the product

Do not insert metal or flammable materials through the vent and into the product. Do not spill water on the product.

### ■ Warning about errors during operation

If the product emits smoke, fire, unusual odors, or abnormal noise while in use, stop using the product immediately. Turn off the switch and disconnect the power cable from the AC outlet to cut off the electric power supply. Contact our company or one of our service centers.

---

---

## USING THE PRODUCT SAFELY

---

---

### ■ **Input/output Terminal**

Maximum input to the input terminals is specified to prevent the product from being damaged. Do not supply input, exceeding the specifications that are indicated in the "SPECIFICATIONS" section of this manual. Also, do not supply power to the output terminals from the outside. Failure to heed this warning may cause the product to fail.

### ■ **Calibration**

The performance and specifications of the product were inspected under strict quality control before shipment. However, the aging of the parts may cause the performance and the specifications to change. To ensure the performance and specifications of the product remain unchanged, we recommend that you have the product calibrated periodically. For calibration, please contact our company or one of our service centers.

### ■ **Daily Maintenance**

Do not use thinner, benzine or other solvents to clean the case, panels, knobs, etc. of the product. Doing so may cause the coating to peel off or the resin surface to deteriorate.

Use soft cloth moistened with neutral detergent to lightly clean the case, panels, knobs, and other parts.

While cleaning, be careful not to let water, detergent, or other foreign materials into the product. If a liquid or metal gets into the product, electric shock or fire may occur.

Before cleaning the product, make sure to disconnect the power cable from the AC outlet to cut off the electric power supply.

Use the product correctly and safely, observing the above warning and caution items. This manual indicates caution items in each individual section. Observe these caution items to correctly use the product.

If you have questions or comments about the content of this manual, contact our company or one of our service centers.

# 1. GENERAL

## 1-1. General

The PSF-H Series is a variable output type high-performance switching DC stabilized power supply unit. It incorporates a high-frequency current suppression circuit and is applicable to the rated source voltage from AC100V to 240V without the need of switching. It offers wide-range voltage and current outputs within the maximum rated power range. It also has a variable constant power function. It has such standard features as voltage and current setting, output On/Off, monitor output and other functions through external connectors. The frame depth is smaller than the traditional models for saving the installation space and providing a wider work space. The PSF-H Series is able to execute sequence programs, which are written in it using the optional interface board in advance, without anything else.

It is possible to control the PSF-H Series from a Personal computer through the optional GP-IB, RS-232C or USB interface board.

The application software exclusive for the PSF-H series may be downloaded from our homepage.

Homepage address – <https://www.texio.co.jp/>

## 1-2. Applicable Products

Product name	Voltage range	Current range	Power range
PSF-400H	0V to 800V	0A to 3A	0W to 400W
PSF-800H	0V to 800V	0A to 6A	0W to 800W
IF-60GP (GP-IB)	◆ Optional GP-IB interface board For details of functions, see “8. EXTERNAL CONTROL THROUGH INTERFACE BOARD” in this instruction manual.		
IF-60RU (RS-232, USB)	◆ Optional RS-232C and USB interface board For details of functions, see “8. EXTERNAL CONTROL THROUGH INTERFACE BOARD” in this instruction manual.		

## 1-3. Features

- Flexible range Output  
Capable of wide-range voltage and current setting within the rated power range.
- Constant-Power Control  
Provides constant-power (CP) control in addition to constant-voltage (CV) and constant-current (CC) controls.

- **Power Factor Correction Circuit**  
A built-in power factor correction circuit ensures compatibility to a wide AC input voltage range from AC100V to 240V without the need of switching. It also suppresses harmonic current.
- **Rotary Panel Operation Unit**  
The panel operation unit may be rotated by 90 degrees for easy-to-see monitoring in either horizontal or vertical installation.
- **Off Timer Function**  
Turns off output automatically after a lapse of preset time in order to prevent “a failure to turn off output” or “over-charging” even in the case where the user does any other work without turning it off.
- **Sequence (SEQ) Function**  
Executes data read from a Personal computer through the optional interface board on the panel operation unit. Two operation modes are available: Manual mode (for execution while checking the step details), and automatic mode (for automatic execution of steps). (100 steps, 999 cycles)
- **Protective Functions**  
Has internally fixed protective functions, which are OVP, OCP and OHP. Also has OVP and OCP functions, which may be set on the panel operation unit.
- **Preset Functions (Three Points)**  
Pressing a preset key directly selects a preset value, which is set in advance.
- **One Control Operation**  
Provides master-slave one control operations.
- **External Control Function**  
Offers voltage- and resistance-based controls, voltage monitoring, current monitoring, output On/Off, alarm, CV/CC status and other functions as the standard features.
- **Options**  
Two types of optional boards, GP-IB + local bus board and RS-232C + USB + local bus board, are available for applications with several built-in units, which are operated simultaneously in a factory, etc.  
It is possible to store sequence programs and read voltage and current data if application software is created.
- **Space Saving Design**  
The frame depth is shorter than our other products for easy installation on a desk or other small space.

## 1-4. Accessories

Make sure the accessories are attached correctly.

If there are any problems, please contact one of our sales branches.

- (1) AC power cable
- (2) Front output terminal plugs (one red pair, one white pair)
- (3) External control connector (26-pin)
- (4) Semi covers for external control connector (2 pcs)
- (5) Output ground cable
- (6) Screws (for attaching the output ground cable)
- (7) CD-ROM (Instruction manual)

Due to environmental considerations, it may not be included.

## 2. SPECIFICATIONS

### ● Output Specifications

Model	PSF-400H	PSF-800H
Rated output voltage	800.0V	
Setting accuracy	0.1%setting±2digit (23°C±5°C)	
Resolution	100mV	
Display accuracy	0.2%reading±2digit (23°C±5°C)	
Rated output current ※1	3.00A	6.00A
Setting accuracy	0.2%setting±2digit (23°C±5°C)	
Resolution	10mA	
Display accuracy	0.3%reading±2digit (23°C±5°C)	
Rated output power ※2	400W	800W
Setting accuracy	±10W. Output voltage should be at least 1% of the rated voltage	
Resolution	10W	
Display accuracy	0.5%reading±Vout × 40mA (23°C±5°C)	

※1: The maximum output current through the front output terminals is 3A(400H)、or 6A(800H).

※2: Switching from the constant-voltage (CV) or constant-current (CC) mode into the constant-power (CP) mode or vice versa is subject to over-shoot ringing, etc.

### ● Input Specifications

Model	PSF-400H	PSF-800H
Input voltage	AC100V to 240V, single-phase, frequency: 50Hz or 60Hz	
Power consumption ※3	560VA	1120VA
Power factor ※4	0.99	
Rush current	35Amax.	35Amax.

※3, 4: At the rated output voltage and AC100V input

### ● Constant-Voltage Characteristics

	PSF-400H	PSF-800H
Source fluctuation ※5	0.01% ±20mV of rated voltage	
Load fluctuation ※6	0.01% ±30mV of rated voltage	
Ripple noise (p-p) ※7	250mV	300mV
	Output voltage should be at least 1% of the rated voltage	
Ripple noise (rms)※8	20mV (When current is 2A or lower)	25mV (When current is 2A or lower)
	35mV (When current is higher than 2A)	40mV (When current is higher than 2A)
	Output voltage should be at least 1% of the rated voltage	
Transient response (typ.)※9	7ms	
Rise time (typ.)※10	200ms(rated load)	200ms(no load)
Fall time (typ.)※11	500ms(rated load)	1000ms(no load)
Temperature coefficient (typ.)※12	±100ppm/°C(after 30-minute warming up)	

● Constant-Current Characteristics

	PSF-400H	PSF-800H
Source fluctuation ※5	0.05%±10mA of rated current	
Load fluctuation ※13	0.05%±15mA of rated current	
Ripple noise (rms)	15mA	20mA
Temperature coefficient (typ.)※12	±200ppm/°C(after 30-minute warming up)	

● Constant-Power Characteristics

	PSF-400H	PSF-800H
Source fluctuation※5	0.5%±10W	

※5: Fluctuation when the source voltage is changed by ±10% in the range from AC100V to 240V.

※6: Fluctuation when the load is changed from the rated load into no load (open circuit) at the rated output voltage.

※7: Measured at the frequency up to 20 MHz.

※8: Measured at the frequency up to 300kHz.

※9: Response time till the output voltage is restored to the range within 0.1% + 10 mV of the rated output voltage when the output current is changed from 50% to 100% of the maximum output current at the rated output voltage.

※10: Value with a fixed load.

Time until the output voltage increases up to 10% to 90% of the rated output voltage.

※11: Value with a fixed load.

Time until the output voltage decreases down to 90% to 10% of the rated output voltage.

※12: Value after 30 minutes of warming up (excluding external control).

※13: Fluctuation when the load is changed from the rated load into no load (short circuit) at the rated output current.

## ● Functions

Constant-voltage (CV) control with external voltage	Output voltage: Approx. 0V to 800V for external voltage: 0V to 10V
Constant-voltage (CV) control with external resistance	Output voltage: Approx. 0V to 800V for external resistance: 0Ω to 10kΩ
Constant-current (CC) control with external voltage	Output current: Approx. 0A to 3A (400H) or 0A to 6A (800H) for external voltage: 0V to 10V
Constant-current (CC) control with external resistance	Output current: Approx. 0A to 3A (400H) or 0A to 6A (800H) for external resistance: 0Ω to 10kΩ
External On/Off control	On/Off at contact, short: On, open: Off
Output voltage monitor signal	Approx. 0V to 10V for 0V to 800V output voltage.
Output current monitor signal	Approx. 0V to 10V for 0A to 3A(400H) or 0A to 6A(800H) output current.
Constant-voltage (CV) status signal	Open collector, active Low.
Constant-current (CC) status signal	Open collector, active Low.
Alarm signal output	Open collector, active Low.
Alarm signal input	Turns off output when shorted.
Remote sensing function	Compensates for voltage drop up to 1V (single side). Within rated voltage at both ends of power supply.
Parallel one-control operation	Up to two units
Preset function	A maximum of three points are presettable.
Off timer (OFF TIMER) function	Time until turning off output is presettable. Setting range: 10min. to 99hrs. & 50min.
Key lock function	Disables operations on front panel.
Sequence function	Number of steps: 0 to 99 Step time: 1 to 9999 (sec.) Number of cycles: 1 to 999 (---: Infinite) The product is capable of simple program operations using the exclusive application software. The application software exclusive for sequence operation may be downloaded from our homepage.

## ● Protective functions

Over-voltage protection (OVP): Fixed ※14	Output Off when output voltage exceeds 110% of rated voltage.
Over-voltage protection (OVP): Variable ※15	Presetable in range from 10V to 840V on front panel. Output Off when OVP works.
Over-current protection (OCP): Fixed ※14	Output Off when output current exceeds 110% of rated current.
Over-current protection (OCP): Variable ※15	Presetable in range from 0.1A to 3.15A(400H) or 0.1A to 6.30A(800H) on front panel. Output Off when OCP works.
Overheat protection (OHP)※14	Output Off at the internal heat sink temperature over the set temperature.

※14: Throw the POWER switch again to reset.

※15: Throw the POWER switch again or press the ESC key to reset.



● Environmental Conditions

Operating temperature range	0°C to +40°C
Operating humidity range	30% RH to 80% RH (No dew condensation)
Storage temperature range	-20°C to +70°C
Storage humidity range	30% RH to 80% RH (No dew condensation)

● Others

Cooling method	Forced cooling with fan motor
To-GND voltage	±DC1000V
Dielectric strength voltage	Power In terminals - frame: AC1500V, 1min. Power In terminals - output terminals: DC3200V, 1min.
Insulation resistance	Power In terminals - frame: DC500V, 30MΩ or more Power In terminals - output terminals: DC1000V, 30MΩ or more Output terminals - frame: DC1000V, 30MΩ or more
Outside dimensions (Projections not included.)	124(H)mm × 210(W)mm × 290mm(D)
Weight	PSF-400H: Approx. 5kg PSF-800H: Approx. 6kg

● One-Control Operation Setting Table

PSF-400H

Item		Single	Parallel connection
		400H	400H × 2
		400W	800W
Voltage setting	SLOW	100mV	
	FAST	10V	
	Range	0V to 820V	
	Min. display digit	100mV	
Current setting	SLOW	10mA	100mA
	FAST	1A	1A
	Range	0A to 3.07A	0A to 6.1A
	Min. display digit	10mA	
Power setting	SLOW	10W	20W
	FAST	100W	200W
	Range	10W to 410W	20W to 820W
	Min. display digit	1W	
OVP setting	SLOW	1V	
	FAST	100V	
	Range	10V to 840V	
	Min. display digit	100mV	
OCP setting	SLOW	10mA	20mA
	FAST	1A	2A
	Range	0.1A to 3.15A	0.2A to 6.3A
	Min. display digit	10mA	10mA

In parallel connection, the minimum digit of current display is 100mA.

In some model combinations, the resolution of current setting is different from the minimum digit of current display and the display may not be changed by one click of the encoder.

## PSF-800H

Item		Single	parallel connection
		800H	800H × 2
		800W	1600W
Voltage setting	SLOW	100mV	
	FAST	10V	
	Range	0V to 820V	
	Min. display digit	100mV	
Current setting	SLOW	10mA	100mA
	FAST	1A	1A
	Range	0A to 6.15A	0A to 12.3A
	Min. display digit	10mA	100mA
Power setting	SLOW	10W	20W
	FAST	100W	200W
	Range	10W to 820W	20W to 1640W
	Min. display digit	1W	
OVP setting	SLOW	1V	
	FAST	100V	
	Range	10V to 840V	
	Min. display digit	100mV	
OCP setting	SLOW	10mA	20mA
	FAST	1A	2A
	Range	0.1A to 6.3A	0.2A to 12.6A
	Min. display digit	10mA	10mA

In parallel connection, the minimum digit of current display is 100mA.

In some model combinations, the resolution of current setting is different from the minimum digit of current display and the display may not be changed by one click of the encoder.

● Default Setting and Storage after Power Off

Default Setting List of PSF-H Series

Item	Initial setting(400H/800H)	Storage after power off
Voltage	0.0V	○
Current	0.00A	○
Power	410W/820W	○
OVP	840.0V	○
OCP	3.15A/6.30A	○
Display mode	V/A	○
Menu display	Initialized when power is turned off.	×
Operation mode	V	○
External voltage control	OFF	○
External resistance control	OFF	○
External output on/off	IN	○
Preset function	OFF	○
Preset item: Voltage	0V	○
Preset item: Current	0A	○
Preset item: Power	410W/820W	○
Off-timer function	OFF	○
Sequence function	OFF	○
Sequence start No.	0	○
Sequence end No.	99	○
Sequence repetition number	1	○
Sequence item: Voltage	0V	○
Sequence item: Current	3.07A/6.15A	○
Sequence item: Power	410W/820W	○
Sequence item: Output	OFF	○
Sequence item: Time	1 秒	○
Key lock function	OFF	×
One-control operation	OFF	○
Output status	Initialized when power is turned off.	×
Sequence operation status	× (Stop status)	×
Off-timer operation status	× (Non operating status)	×
System address	1	○
Personal computer address	3	○

### 3 PRELIMINARY INSTRUCTIONS

Be sure to read through this section before using the PSF-H Series power supply unit.



- **Checking the Source Voltage**

Use the PSF-H Series power supply unit within the rated source voltage range, which is AC100V to 240V (allowance:  $\pm 10\%$ ), single-phase, 50Hz or 60Hz.

- **Connecting the AC Power Cable**

Be sure to use the AC power cable supplied with the product.



- **AC Power Cable**

Attached AC cable is different according to the destination. Make sure the rating of the AC cable.

- **Grounding**

Be sure to ground the PSF-H Series power supply unit to prevent electric shock or electrocution.

A failure of grounding the unit may result in malfunctioning due to external noises and/or increased noises generated by the unit.

Be sure to connect the GND terminal if a 2P-3P conversion plug is used owing to unavoidable circumstances.

- **Instructions on Using the PSF-H Series in the Floating Condition**

Using the PSF-H Series power supply unit in the floating condition is subject to high potential between the frame and output terminals.

If the frame and output terminals are short-circuited in this condition, a measuring instrument or load connected with the PSF-H Series may be broken. Be very careful.

Such high potential may remain in the noise reduction capacitor after use. Never short-circuit the terminal or touch them by hand. Disobedience to this instruction may cause electric shock or electrocution.

- **Instruction on Using the Output Terminals**

The PSF-H Series is a floating type power supply unit. Connect either output terminal on the rear panel with the GND terminal of the frame, if output should be grounded. The output terminals on the front panel are auxiliary output terminals, whose maximum current is 3A(400H) or 6A(800H). Note that using the front output terminals may not satisfy the electrical specifications.

Do not use the front and rear output terminals simultaneously. Using them together may result in troubles.

- **Instruction on Turning On Power**

When the PSF-H Series power supply unit is turned on, the version data of the internal ROM are displayed, the model name, presence or absence of the interface, address and other data are displayed, and then the set voltage and current are displayed.

- **Precaution for turning off power**

The PSF-H Series power supply unit stores set values immediately before the source voltage is shut off or the POWER switch is turned off. These stored values serve as the initial values when it is turned on next time.

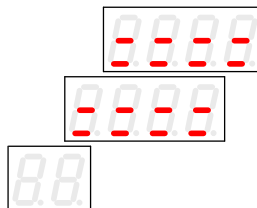

Display while storing the set values

Once power is turned on or off, the user should wait for five seconds or more before turning it off or on. If power is turned on and off repeatedly at intervals of five seconds or less, the unit may fail to store the set values, the power fuse may be deteriorated due to a fault of the rush current limit circuit, or the POWER switch may become defective.

## 4. DEVICES ON PANELS

### 4-1. Front Panel



Fig4-1 Front Panel(PSF-800H)

#### 1. POWER ON/OFF switch

Press the switch to the (I) position to turn on the power supply unit.

Press it again to turn off the unit (the switch returns to the Out position).

#### 2. Front output terminals

Output is supplied through these terminals.

The maximum current is 3A(400H)、or 6A(800H).

#### 3. Front grill

This is a ventilation grill for taking air for cooling the internal circuits into the unit.

It is detachable and has a dust filter inside. Clean the filter periodically.

#### 4. Rubber shoes

Detachable.

If the unit is mounted in a rack and the shoes are not needed, they may be removed.

## 4-2. Operation Panel



Fig 4-2 Operation Panel(PSF-800H)

### 5. Address No., number of steps, number of cycles, and menu No.

Normal operation	Sequence operation	Menu
Not displayed.	Number of steps is displayed.	Menu No. is displayed.

### 6. Current 7-segment LED

Normal operation	Sequence operation	Menu	Alarm
Current or power is displayed.	Step No. is displayed.	Set item is displayed.	OVP, OCP, HARD or OHP is displayed.

The "W" LED on the right of the 7-segment LED is lit in the power display state.

### 7. Voltage 7-segment LED

Normal operation	Sequence operation	Menu	Alarm
Voltage or power is displayed.	Cycle No. is displayed.	Set parameter is displayed.	OVP, OCP, HARD or OHP is displayed.

The "W" LED on the right of the 7-segment LED is lit in the power display state.



#### 8. ESC/DISP key

Changes the channel display, sequence operation display (i.e., step No. and cycle No.), remaining time in off-timer operation and other displays.

When the menu is displayed, pressing it exits the function selection mode and returns to the normal mode.

#### 9. ENTER/CHECK key

Alternates the output value and set value.

When the output is on, every press of the ENTER/CHECK key alternates output value display and set value display.

When the menu is displayed, press this key to validate functions and values.

#### 10. MENU key

Used for setting and selection of various functions.

#### 11. OUTPUT key (red)

This key turns on or off output. The LED is lit when output is turned on.

#### 12. Function LEDs

These LEDs display the On/Off state the functions.

The (green) LED is lit when the corresponding function is activated.

#### 13. Rotary encoder (hereinafter merely referred to as encoder)

Used to select the functions and change the values.

#### 14. ROTATE key

The panel operation unit of the PSF-H Series may be rotated by 90 degrees to ensure easy operation in either horizontal or vertical installation.

Hold the encoder and rotate the panel operation unit while pressing the key.

#### 15. FAST/LOCK (3s)/LOCAL change-over key

Changes the digit of the voltage, current or power set value, locks panel operation, or changes the remote mode into the local mode.

The LED color depends on the status.

FAST (green) : The setting resolution is 10V, 1A or 100W.

LOCK (3s) (red) : Operations on the front panel are disabled.

REMOTE (orange) : Lit during communication through the optional board.

#### 16. PRESET 3 key (green)

Reads out data stored in PRESET 3.

Serves as a jump key to a number one larger than the step number in the sequence mode.

17. PRESET 2 key (green)

Reads out data stored in PRESET 2.

Serves as a jump key to a number one smaller than the step number in the sequence mode.

18. PRESET 1 key (green)

Reads out data stored in PRESET 1.

Serves as a start/pause key in the sequence mode.

19. A key (green)

Used for current setting. Press the key and rotate the encoder to change the set value. If the V key is pressed while holding the A key, both LEDs are lit and the voltage 7-segment LED enters the power display mode.

20. V key (green)

Used for voltage setting. Press the key and rotate the encoder to change the set value. If the A key is pressed while holding the V key, both LEDs are lit and the current 7-segment LED enters the power display mode.

### 4-3. Rear Panel

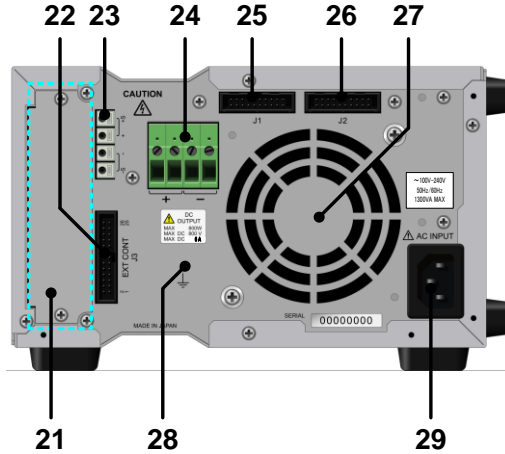

Fig 4-3 Rear Panel(PSF-800H)

#### 21. Optional board slot

Used to install the optional IF-60GP or IF-60RU board for controls through the interface. The product is supplied with slot covered with a blank panel.

#### 22. J3 external control connector

Used for various controls.

◆ See section “5-7. External Control Functions” below.

Pin assignment of this connector is as shown below.

Pin No.	Signal name	Function
1~13	NC	
14	EXT CV CONTROL IN	Constant-voltage control input pin. Control from approx. 0V to 800V at 0V to 10V in the external voltage control mode. Control from approx. 0V to 800V at 0k $\Omega$ to 10k $\Omega$ in the external resistance control mode.
15	EXT CC CONTROL IN	Constant-current control input pin. Control from approx. 0A to 3A(400H) or 6A(800H) at 0V to 10V in the external voltage control mode. Control from approx. 0A to 3A(400H) or 6A(800H) at 0k $\Omega$ to 10k $\Omega$ in the external resistance control mode.
16	COM	COM. Connected with the negative output terminal.
17	EXT V MON OUT	Output voltage monitor pin. Outputs approx. 0V to 10V for 0V to 800V output voltage.
18	EXT A MON OUT	Output current monitor pin. Outputs approx. 0V to 10V for 0A to 3A(400H) or 6A(800H) output current.

Pin No.	Signal name	Function
19	COM	COM. Connected with the negative output terminal.
20	EXT ALARM IN	Causes the alarm status when short-circuited with the COM pin.
21	EXT OUTPUT IN	Turns on output when short-circuited with the COM pin.
22	COM	COM. Connected with the negative output terminal.
23	EXT CV STATUS OUT	Open collector output. Set to the L level when the CV mode.
24	EXT CC STATUS OUT	Open collector output. Set to the L level when the CC mode.
25	ALARM OUT	Open collector output. Set to the L level when the alarm mode.
26	STATUS COM	COM of pins 23, 24 and 25.

### 23. Sensing terminals

Used to change the sensing point.

Short-circuited before shipment to select the internal sensing.

◆ See section “5-6. Output Voltage Remote Sensing” below.

### 24. Rear output terminals

Power of the PSF-H Series power supply unit is output through these terminals. On each terminal block, the positive (+) terminal is on the first and second pin at left side and the negative (–) terminal is on the first and second pin at right side when the unit is viewed from the back.

Connect either output terminal with the accessory cable and screw with the  $\perp$  mark near the terminal block if it need be grounded with the frame.

### 25. J1 control signal input connector

This connector is provided for one-control operation.

Use the optional one-control operation cable.

◆ See sections “6-2. One-Control Parallel Operation” below.

### 26. J2 control signal output connector

This connector is provided for one-control operation.

Use the optional one-control operation cable.

◆ See sections “6-2. One-Control Parallel Operation” below.

### 27. Exhaust grill

Air taken into the unit from the front is blown out through this grill. Leave a 30cm or more space behind the rear panel for good ventilation. If there is some object near the rear panel, the temperature inside the power supply unit may rise excessively.

28. Output ground terminal

Used to ground the positive or negative output terminal of this unit.

An output ground cable should be used to ground the output terminal.

29. AC INPUT



Connect the AC power cable supplied with the unit with this plug receptacle and supply commercial power to the unit.

## 5. OPERATION PROCEDURES

### 5-1. Connecting AC Power Cable

- Make sure that the power source is shut off.
- Use the AC power cable supplied with the product.
- Plug the connector of the AC power cable into the AC INPUT receptacle on the rear panel.

### 5-2. Connecting Load with Output Terminals



**Be sure to connect the load in the condition where the POWER switch is off.**

**To connect a load, use cables having large enough current capacity for the rated output and current in order to prevent a fire.**

**The current capacity of the cables should be still higher if the cables are twisted to reduce noises or avoid malfunctioning.**

Use cables of the rated voltage over the grounding voltage (1000V) for the load. The front output terminals and rear output terminals are connected internally. Even when the front output terminals are used, there is still a risk of electric shock because the rear output terminals carry voltage. Exercise extreme care when connecting cables.

#### 5-2-1. Connection with the rear output terminals

- (1) Remove AC cable from AC INPUT.
- (2) Insert the load line and then use a flathead screwdriver or similar tool to firmly secure it.
- (3) If necessary, use the supplied output ground cable and screw to establish a positive or negative ground connection to the output ground terminal (  $\perp$  mark).

Noises at the load end may be reduced by twisting the cables to the load or connecting a film capacitor of low high-frequency impedance (several  $\mu\text{F}$ ) and an electrolytic capacitor (several hundred  $\mu\text{F}$ ) to the load end.

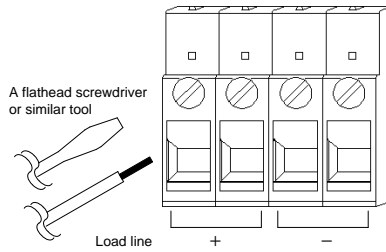

Fig 5-1 Connection with Rear Output Terminals

The negative potential of the external voltage control is the same as that of the negative output terminal. If the power supply unit is grounded at the positive terminal and the power source for external control is grounded at the negative terminal, the load cables for external voltage control short-circuits the output of the power supply unit, resulting in troubles. Use the power source for external voltage control in the floating condition.

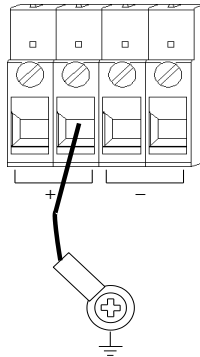

Fig 5-2 Positive Grounding Connection



**The front and rear output terminals are connected internally. Terminals that are NOT in use carry output voltage.**

**Be careful not to touch the terminals. Failure to heed this warning may result in electric shock.**

## 5-2-2. Assembling and connecting the front output terminal plug

The cable (load line) and 1.5 mm wrench are not supplied.

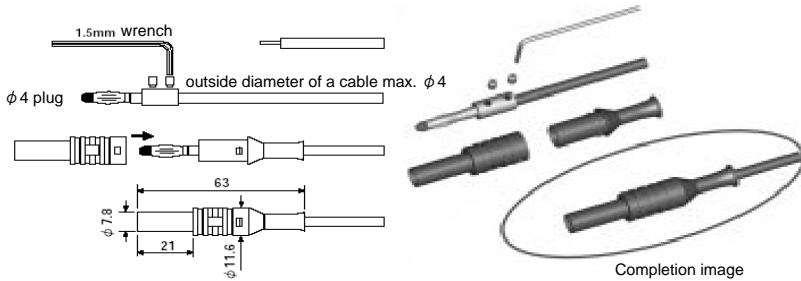

Fig 5-3 Assembly diagram of the front output terminal plug

- (1) Insert the cable (load line) into the plug.
- (2) Use a 1.5 mm wrench to fasten the 2 screws.
- (3) Insert the cover into the plug and make sure it hooks into place (completion image).
- (4) Turn off the power switch of the unit.
- (5) Insert the above-mentioned plug into the front output terminal.
- (6) When current is drawn from the rear output terminals, the plug must be removed from the front output terminal.



**CAUTION**

**For safety, NEVER output power through both the front and rear output terminals.**



### 5-3. Operation Ranges

The PSF-H Series power supply units offer wider ranges of voltage and current setting within the rated power range than our traditional models.

- Voltage setting range : 0V to 800V (All models)
- Current setting range : 0A to 3A (PSF-400H)  
: 0A to 6A (PSF-800H)
- Power setting range : 10W to 400W (PSF-400H)  
: 10W to 800W (PSF-800H)

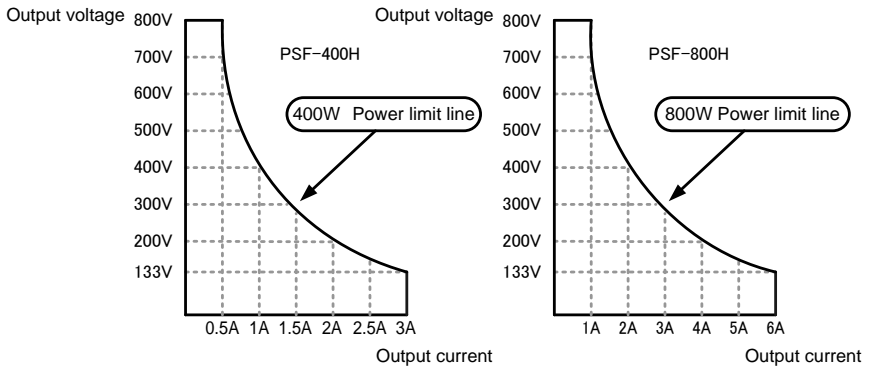
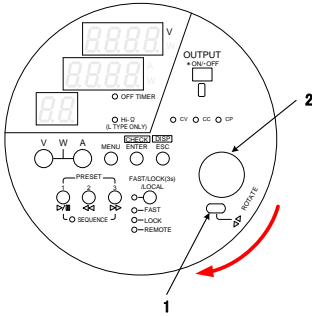

Fig 5-4 Operation ranges

## 5-4. Various Setting

### 5-4-1. How to rotate display panel by 90 degrees

The panel operation unit of the PSF-H Series may be rotated by 90 degrees to ensure easy operation in either horizontal or vertical installation.



Operation procedure

1. while pressing the ROTATE key
2. Hold the encoder the panel operation unit. A “click” sound is heard and the panel operation unit is locked.

To return the unit to its original position, hold the encoder and turn it counterclockwise 90 degrees while pressing down the ROTATE key.

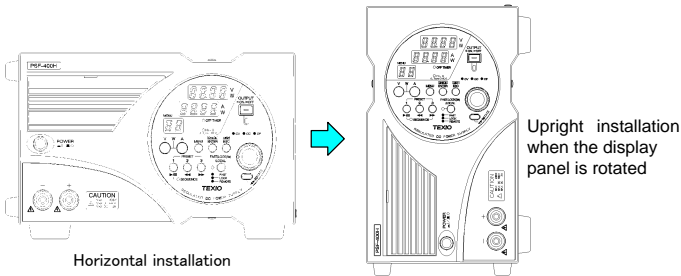

**Be sure to confirm that the POWER switch is off before rotating the display panel.**

**If the display panel is rotated with power on, the set value may change due to rotation of the encoder. Be careful.**

### 5-4-2. Various Setting

First, press the POWER switch to turn on power. The power supply unit gives initial display (version and so forth) for several seconds and then displays the stored set values.

The unit stores the set values automatically when the source voltage is cut off or the POWER switch is shut off.

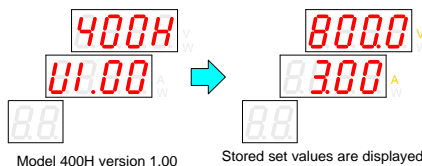

Model 400H version 1.00

Stored set values are displayed

### 5-4-3. How to set voltage

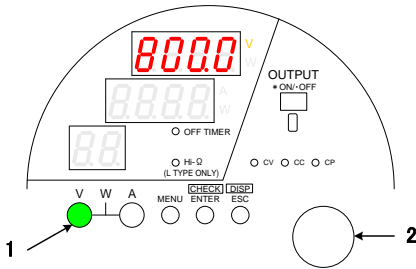

#### Operation procedure

1. Press the V key, which is then lit in green.  
If not, press the V key to turn it on.
2. Set an intended value with the encoder.

### 5-4-4. How to set current

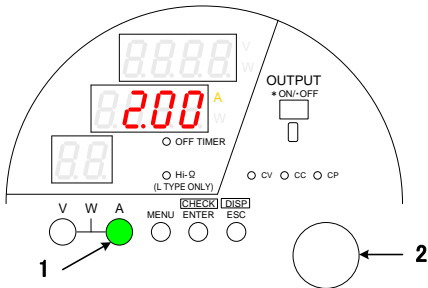

#### Operation procedure

1. Press the A key, which is then lit in green.  
If not, press the A key to turn it on.
2. Set an intended value with the encoder.

### 5-4-5. How to set power

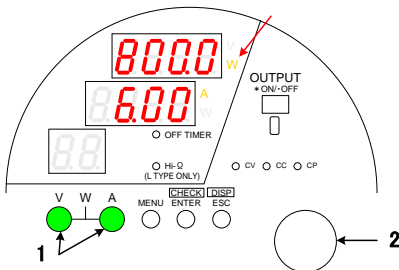

#### Operation procedure

1. Press the V key while pressing and holding the A key.  
A power value then appears in the voltage indicator.

Or, press the A key while pressing and holding the V key.  
A power value then appears in the current indicator.

2. Set an intended value with the encoder.

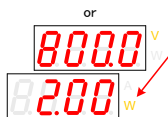

## 5-4-6. How to output

The following output methods are available:

1. Turning output on or off using the OUTPUT key.  
Press the OUTPUT key to turn output on or off.  
Output is on while this key is lit.
2. Turning output on or off using the external control function.  
◆ See Section “5-5-6. External control (ON/OFF) (06)” below.

### 1. Turning output on or off using the OUTPUT key.

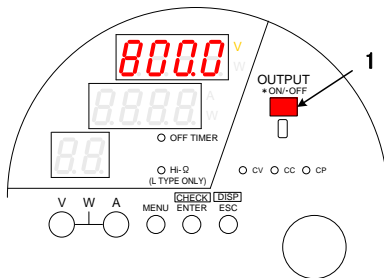

Operation procedure

1. Press the OUTPUT key, which is then lit in red.

The output of the PSF-H series is turned on before the voltage lowers down to 0 (zero) volt if it is turned on and off quickly in the condition in a light load condition. The Off time must be 1 second or more when the output is turned on and off quickly.

◆ See Section “2. SPECIFICATIONS”.

### 5-4-7. How to display the set value in outputting condition

The power supply unit displays the output value in the outputting condition.

Press the ENTER/CHECK key in this condition to change the displayed output value into the set value.

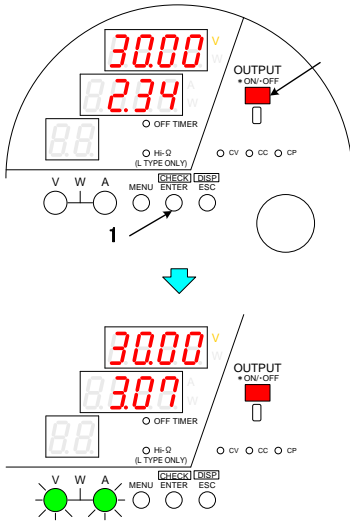

#### Operation procedure

1. When output value display is Every press of the ENTER/CHECK key alternates the setting mode and output mode.

When output value display is changed into set value display in the outputting condition, the A key or V key blinks, indicating that the set value is being displayed.

The set value is changed if the encoder is rotated in the setting mode.  
 The output value is changed if the encoder is rotated in the output mode.  
 Do not touch the encoder to check the set value only.

### 5-4-8. How to invalidate on-panel operations (Key lock function)

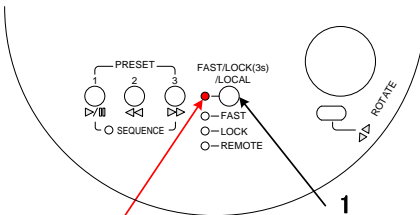

#### Operation procedure

1. Press and hold the FAST/LOCK(3s)/LOCAL key until the LED next to the key is lit in red (3 sec. or more).

To cancel key lock, press and hold the key until the LED next to it goes out (3 sec. or more).

This key serves as the FAST, LOCK (3s), and LOCAL keys. Even if the power supply unit is in the FAST state (green), the FAST state is canceled and the normal (SLOW) state is restored when the key is reset in order to avoid danger. Even in the key locked condition, the OUTPUT key is only functional to avoid danger. (output off only)

## 5-5. Various Functions Available on Menu

Introduction:

- Every press of the MENU key changes the menu numbers.
- MENU options are available from “01” to “06”.
- Press the ESC/DISP key to return from the MENU setting condition to the normal condition.
- To deactivate a function, select the setting mode of that function again from the menu and deactivate it.

Use the following keys to set the functions:

- MENU key : Selects the menu options.
- ENTER/CHECK key : Validates numeric values and items.
- ESC/DISP key : Cancels the menu setting mode (and returns to the normal state)
- Encoder : Selects numeric values and items.

Illustrations in the descriptions below represent the following:

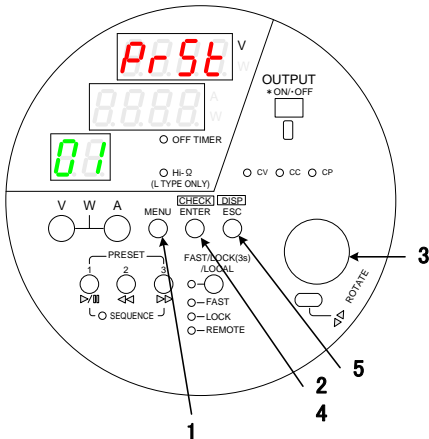
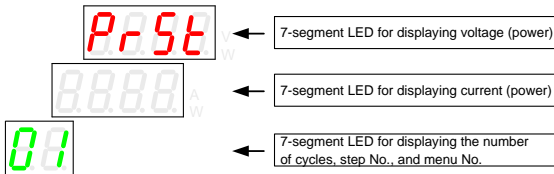

Operation procedure

1. Press the MENU key until an intended function number is displayed.
2. Press the ENTER/CHECK key to validate the function. Proceed to setting of the next item.
3. Set a numeric value or item with the encoder.
4. Press the ENTER/CHECK key to validate it.
5. When all intended items have been set, press the ESC/DISP key to return to the normal state.

Any set value is validated only after the ENTER/CHECK key is pressed.

Be sure to check if the value is set properly after setting it. Some functions may not be set at a time. See “Table 5-1” below and carry out setting properly.

Table 5-1

Set function	No.	Functions that cannot be set or used simultaneously
Preset	01	Sequence External(voltage/resistance)
OVP/OCp	02	-
Off timer	03	Sequence Delay External (ON/OFF)
Sequence	04	Preset Off timer External (voltage/resistance) External (ON/OFF)
External (voltage/resistance)	05	Preset
External (On/Off)	06	Off timer

### 5-5-1. Preset function (01)

This function stores intended set values in advance. It is possible to assign set values to be stored to three PRESET keys.

The values shown below may be preset. Note that any other values may not be stored.

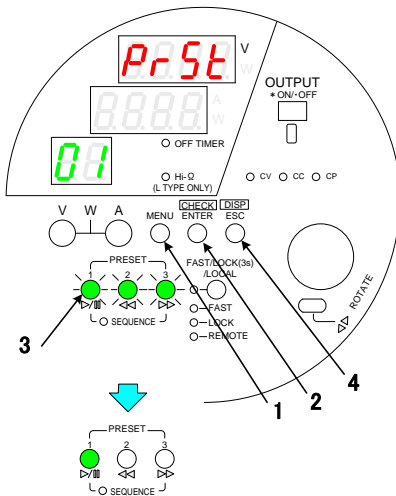

#### Operation procedure

Set the voltage, current and power following the step in  
[“5-4-3. How to set voltage”](#)  
[“5-4-4. How to set current”](#)  
[“5-4-5. How to set power”](#)

1. Press the MENU key until menu number “01” is displayed.
2. Press the ENTER/CHECK key. All PRESET key start blinking green.
3. Press the PRESET key where you want to store the set value. The PRESET key you pressed lights in green and stored.
4. press the ESC/DISP key to return to the normal state.

Once the MENU key is pressed to activate the preset function, setting of the voltage, current and power is disabled. Set intended values to be stored in advance, and store them using the preset function.

## 5-5-2. OVP/OCP function (02)

- **OVP: (Over Voltage Protection)**

The OVP function turns off output when the output voltage of the PSF-H Series exceeds the preset OVP value.

The setting range is from 10.0V to 840.0V. The resolution is 1V.

- **OCP: (Over Current Protection)**

The OCP function turns off output when the output current of the PSF-H Series exceeds the preset OCP value. The setting range is from 0.10A to 3.15A(400H), 6.30A(800H). The resolution is 0.01A. The resolution is different in one-control parallel operation.

- ◆ See Section “2. SPECIFICATIONS”.

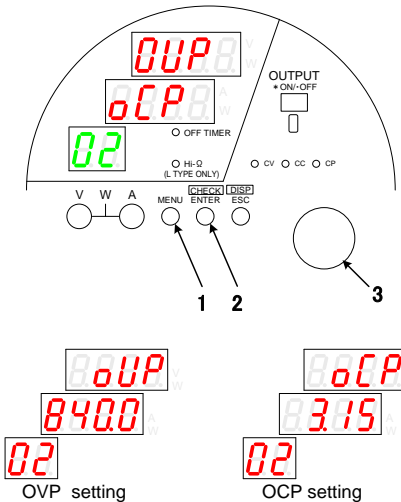

### Operation procedure

1. Press the MENU key until menu number “02” is displayed.
2. Every press of the ENTER/CHECK key alternated OVP and OCP.
3. When an intended function is displayed, rotate the encoder to set an intended value.
4. Press the ENTER/CHECK key to validate it.
5. press the ESC/DISP key to return to the normal state.

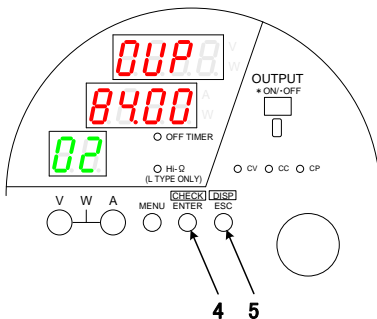



### 5-5-3. OFF timer function (03)

This function deactivates output of the power supply unit automatically.  
It is possible to set the timer-off period in units of ten minutes.

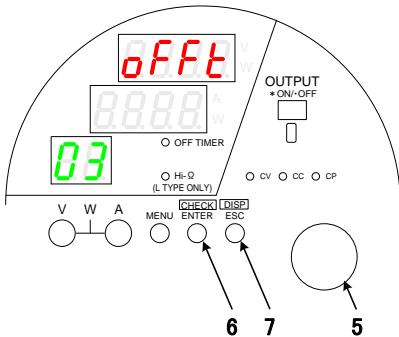
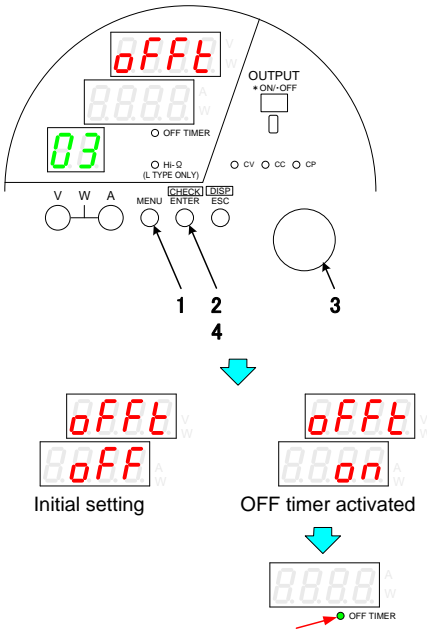

#### Operation procedure

1. Press the MENU key until menu number "03" is displayed.
2. Press the ENTER/CHECK key to enter the OFF timer setting mode.
3. Select ON or OFF with the encoder.  
(The Off Timer is set to OFF before shipment.)
4. Press the ENTER/CHECK key to validate setting.  
Select ON. The OFF timer indicator is then lit in green.
5. Then, set intended time with the encoder.  
The time may be set in units of ten minutes to a maximum of 99 hours and 50 minutes.



The function LED begins to blink when the remaining time becomes less than five minutes.

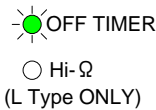

6. Press the ENTER/CHECK key to validate it.
7. Press the ESC/DISP key to return to the normal state.

### 5-5-4. Sequence function (04)

This function executes sequence programs, which are written in the PSF-H Series power supply unit using the optional interface board in advance, without anything else. Access our homepage or consult its distributor for the procedures of writing sequence programs. The application software exclusive for sequence operation may be downloaded from our homepage.

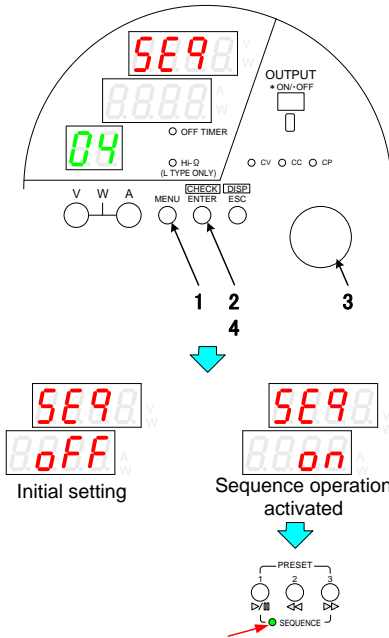

#### Operation procedure

1. Press the MENU key until menu number "04" is displayed.
2. Press the ENTER/CHECK key to enter the OFF timer setting mode.
3. Select ON or OFF with the encoder.  
(The Off Timer is set to OFF before shipment.)
4. Press the ENTER/CHECK key to validate it.  
Select ON. The SEQUENCE indicator is then lit in green.

#### How to set an intended start step number.

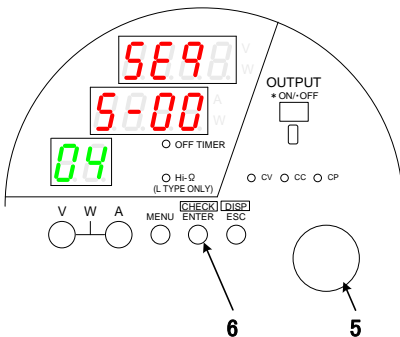

#### Operation procedure

5. Set an intended start step number with the encoder.  
The setting range is from 0 to 99.
- 
6. Press the ENTER/CHECK key to validate it.

How to set an intended end step number.

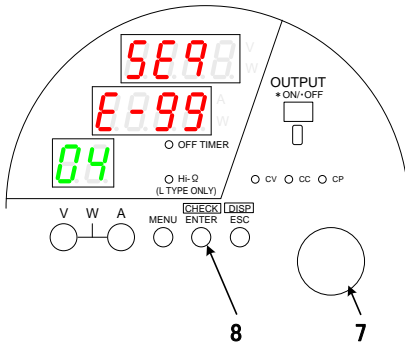

How to set the number of times of repeating.

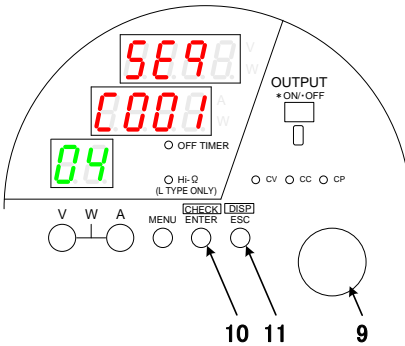

Operation procedure

7. Then, set an intended end step number with the encoder.

The setting range is from 0 to 99.



8. Press the ENTER/CHECK key to validate it.

9. Set the number of times of repeating the steps with the encoder.

The setting range is from 1 to 999 plus"---"(infinite).

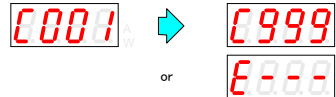

10. Press the ENTER/CHECK key to validate it.

11. Press the ESC/DISP key to quit the setting mode and return to the condition capable of sequence operation.

◆ See Section ["5-9. Usage of sequence Function"](#) for the method of using.

The method of writing the sequence programs is described in the application software exclusive for sequence operation. The following shows an example of the sequence program and the screen of the exclusive application. Note that it is impossible to rewrite the sequence programs on the PSF-H Series power supply unit.

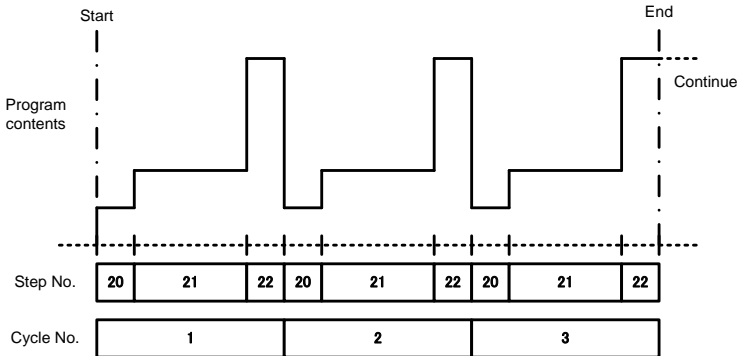

Fig 5-5 Repeating Steps 20 to 22 Three Times, Beginning with Step 20



If output is active at the end of the program as shown in Fig.5-5, the power supply unit remains in the status of the last step even after completion of sequence operation. (Output stays active.)

The last step number must be OFF if output should be turned off on completion of sequence operation.

The power supply unit finishes sequence operation when the OUTPUT key is pressed during sequence operation.

If the OUTPUT key is pressed in a step, where output is active, during sequence operation, output remains active though sequence operation finishes.

#### 5-5-5. External control (external voltage, external resistance) (05)

- Set voltage using external voltage

This function allows the user to control the voltage of the PSF-H Series power supply unit by applying external voltage to the unit. The output voltage is controlled from approximately 0V to approximately 800V output voltage when 0V to 10V is applied from outside.

- Set current using external voltage

This function allows the user to control the current of the PSF-H Series power supply unit by applying external voltage to the unit. The output current is controlled from approximately 0A to approximately 3A(PSF-400H) or approximately 6A(PSF-800H) output current when 0V to 10V is applied from outside.

- Set voltage using external resistance

This function allows the user to control the voltage of the PSF-H Series power supply unit by connecting an external resistance with the unit. The output voltage is controlled from approximately 0V to approximately 800V output voltage when 0  $\Omega$  to 10k  $\Omega$ s connected with the power supply unit.

- Set current using external resistance

This function allows the user to control the current of the PSF-H Series power supply unit by connecting an external resistance with the unit. The output current is controlled from approximately 0A to approximately 3A(PSF-400H) or approximately 6A(PSF-800H) output current when 0  $\Omega$  to 10k  $\Omega$ s connected with the power supply unit.

- ◆ See Sections [“5-7-2. Set voltage with external voltage or resistance”](#) and [“5-7-2. Set current with external voltage or resistance”](#)

The PSF-H Series power supply unit is incapable of simultaneous external voltage and external resistance controls like controlling the set voltage with external voltage and controlling the set current with external resistance.

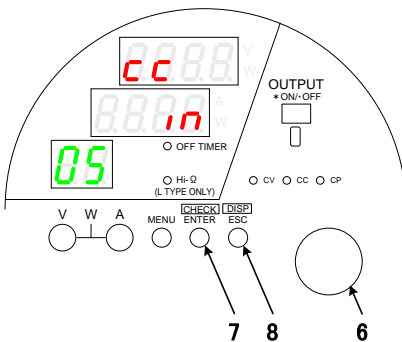
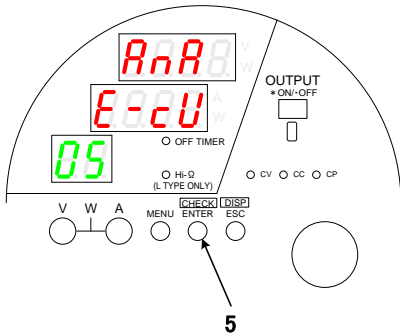
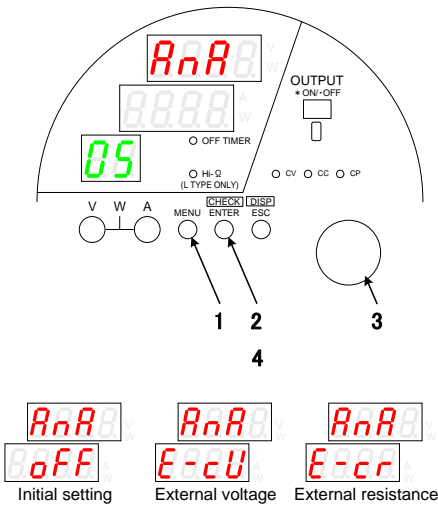

## Operation procedure

1. Press the MENU key until menu number "05" is displayed.
2. Press the ENTER/CHECK key to enter the external control setting mode.
3. Set the intended control external voltage or external resistance with the encoder.  
(The external control is set to OFF before shipment.)
4. Press the ENTER/CHECK key to validate it.
5. Press the ENTER/CHECK key to select,
  - CV** : Set voltage
  - CC** : Set current
6. Select objective of external control with the encoder,
  - IN** : Control on the panel operation unit or from the Personal computer
  - OUT** : Through the optional board External control
7. Press the ENTER/CHECK key to validate it.
8. Press the ESC/DISP key to return to the normal state.

## 5-5-6. External control (ON/OFF) (06)

It is possible to turn on or off the output by shorting or opening the signal pins with external contact signals.

Short circuit: OUTPUT ON, Open: OUTPUT OFF

◆ See Section “5-7-4. Output ON/OFF with external contacts” below.

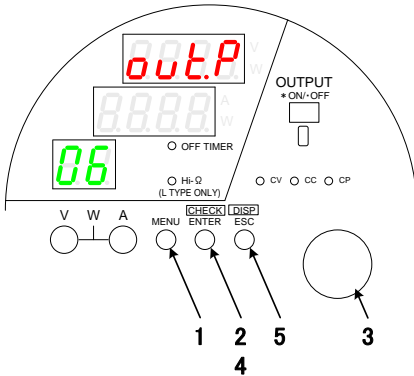

Operation procedure

1. Press the MENU key until menu number “06” is displayed.
2. Press the ENTER/CHECK key to validate it.
3. Select ON or OFF with the encoder.

IN : ON/OFF control with the OUTPUT key.

OUT : ON/OFF control with external contacts.

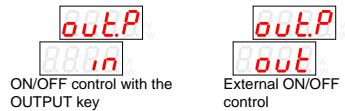

4. Press the ENTER/CHECK key to validate it.
5. Press the ESC/DISP key to return to the normal state.

### 5-5-7. Master-slave function (10)

No panel operations are enabled on the slave units. Besides, the Off Timer, sequence and external control functions of the slave units are initialized. On slave units in parallel connection, “----” is displayed and the monitor value is not displayed. (The monitor value is displayed on the master unit.)

◆ See Sections “6-2. One-Control Parallel Operation”

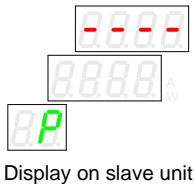
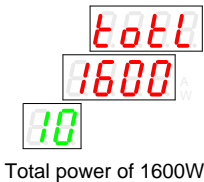
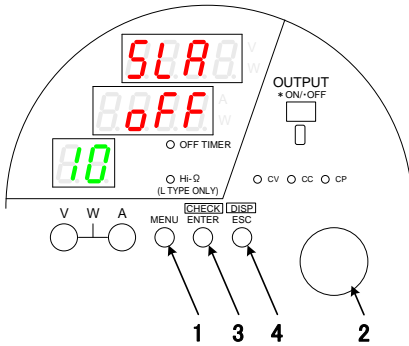

#### Operation procedure

1. Turn on the unit while holding the MENU key.  
Menu number “10” is displayed.
2. Select an intended operation mode with the encoder.

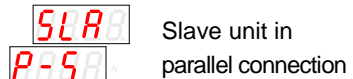
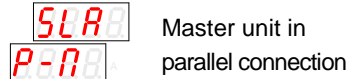

3. Press the ENTER/CHECK key to validate it.  
(The master-slave function is set to OFF before shipment.)

The set power value is displayed if the unit is set as the master unit in a parallel connection.

4. Press the ESC/DISP key to return to the normal state.

The indicator display shown in the left figure appears if the unit is set as the slave unit in a parallel connection.



## 5-6. Output Voltage Remote Sensing

The PSF-H Series power supply unit has an output voltage remote sensing function. It eliminates influences of voltage drop between the power supply unit and load, which is caused by the contact resistance or the resistance of the load cable conductors. It compensates for a voltage of 1V on the single side.

When the voltage remote sensing function is used, the voltage at the front and rear output terminals of the power supply unit must not exceed the rated voltage. Be very careful. If the load is too far from the power supply unit, inductance and capacity of the load cables may cause oscillation. To avoid such oscillation, connect an electrolytic capacitor of several hundred  $\mu\text{F}$  to several thousand  $\mu\text{F}$  to the load terminals.

- (1) Make sure that the POWER switch is off before starting work.
- (2) Disconnect the wire that short-circuits the + and +S terminals or - and -S terminals of four-terminal block on the left of the output terminals on the rear panel.
- (3) Connect the positive sensing terminal (+S) with the positive side of the load and the negative sensing terminal (-S) with the negative side of the load as shown below. If the sensing wires are disconnected, control becomes unstable and voltage over the set voltage is applied to the load. Connect the sensing wires firmly.

Current of approximately 1mA flows through the sensing wires at the rated output voltage. Use AWG 26 to 18 wires as the sensing wires.

◆ See Section, “5-2. Connecting Load with Output Terminals” above.

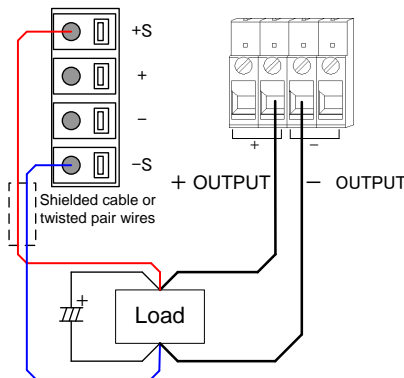

Fig. 5-7 Remote Sensing Connection

## 5-7. External Control Functions

It explains connector (J3) for an external control.

The mounting of the wire to the contact, in order to improve the reliability, please use the (OMRON) special tool XY2B-7006. In addition, the application wire rod is twist line AWG28 - AWG26, external form  $\Phi 1.1$ - $\Phi 1.3$ .

Specifically, please review an instruction manual of XY2B-7006. For details, please confirm the operation manual of XY2B-7006.

In the case of faulty wiring or wiring change, please use the (OMRON) special tool XY2E-0001 that is withdrawn from the housing contact. For details, please confirm the operation manual of XY2E-0001.

### 5-7-1. Output voltage monitor and output current monitor

It is possible to monitor the output voltage and output current of the PSF-H Series power supply unit in voltage.

The internal impedance of the voltage and current monitoring circuits is approximately  $1k\Omega$ .

Be careful not to flow current over 1mA through the monitoring circuits.

(1) Voltage monitor

Pins 17 and 16 (COM)

(2) Current monitor

Pins 18 and 16 (COM)

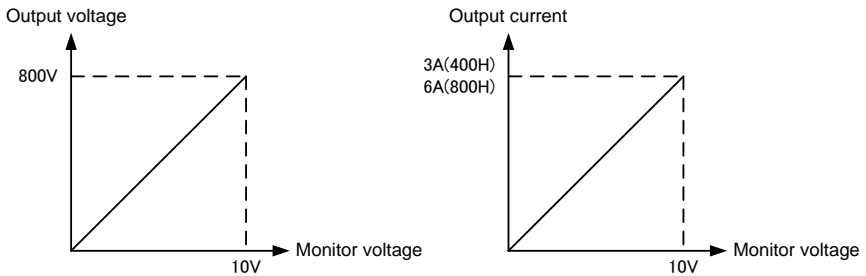
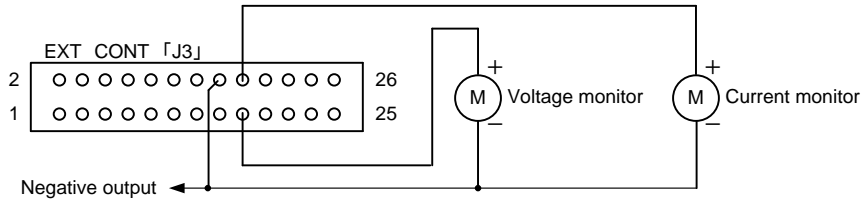

Fig.5-8 Monitor Output Terminal

## 5-7-2. Set voltage with external voltage or resistance

It is possible to control the output voltage by external voltage or external resistance through the connector J3 (EXT CONT) on the rear panel if external control is selected in Section “5-5-5. External control (external voltage, external resistance) (05)” above.

- ◆ For the setting procedures, see Section “5-5-5. External control (external voltage, external resistance) (05)”

The negative side of the external voltage is connected with the negative sensing terminal (-S) of the power supply unit. Use the external voltage source in the floating condition to avoid accidents or malfunctioning.

If the external resistor is disconnected for some reason in the external control mode, excessive voltage is applied to the output. Use a shorting type switch if the constant voltage is to be controlled by changing fixed resistors with the switch. Control by external voltage and control by external resistance use the same pins. Check with control is selected, control by external voltage and control by external resistance, before using the pin.

Pins 14 and 16 (COM)

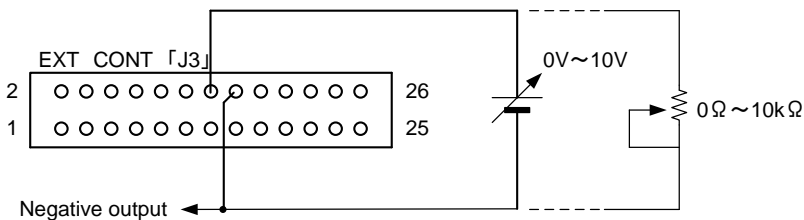

※ Use a shielded cable or twist pair wires for this control

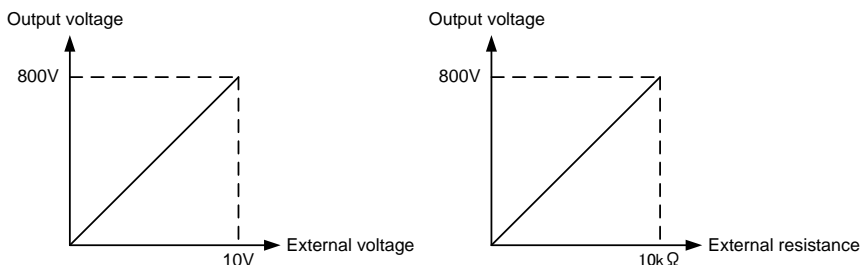

Fig.5-9 External Voltage/Resistance Control Terminal (CV)

### 5-7-3. Set current with external voltage or resistance

It is possible to control the output current by external voltage or external resistance through the connector J3 (EXT CONT) on the rear panel if external control is selected in Section “5-5-5. External control (external voltage, external resistance) (05)” above.

- ◆ For the setting procedures, see Section “5-5-5. External control (external voltage, external resistance) (05)”.

Pins 15 and 16 (COM)

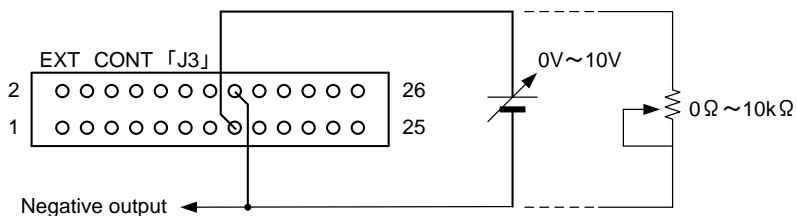

※ Use a shielded cable or twisted pair wires for this control

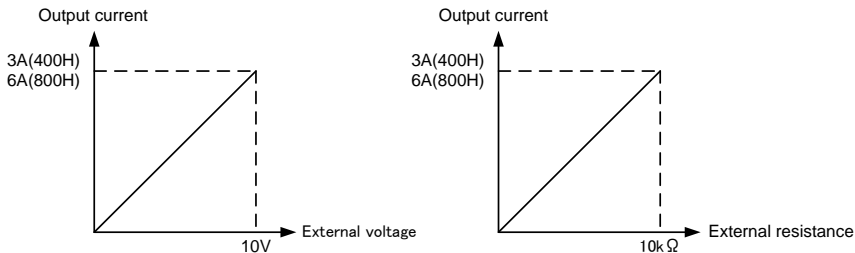

Fig. 5-10 External Voltage/Resistance Control Terminals (CC)

#### 5-7-4. Output ON/OFF with external contacts

It is possible to turn on or off output with external contacts if the external control function is activated in Section “5-5-6. External control (ON/OFF) (06)” above.

◆ For the setting procedures, see Section “5-5-6. External control (ON/OFF) (06)”

Pins 21 and 22 (COM)

Short : OUTPUT ON

Open : OUTPUT OFF

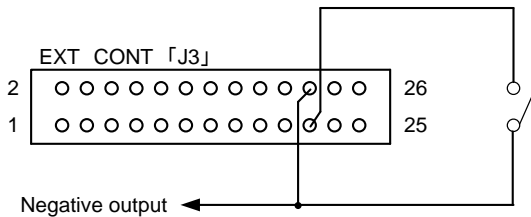

Fig. 5-11 Output ON/OFF Terminals with External Contacts

#### 5-7-5. Alarm function using external contacts

It is possible to bring the PSF-H Series power supply unit into the alarm status forcedly by short-circuiting the external contacts. Output is turned off and “HARD” is displayed on the 7-segment LED when the PSF-H Series power supply unit is brought into the alarm status. Cut off input power or shut off the POWER switch to cancel the alarm status.

Pins 20 and 22 (COM)

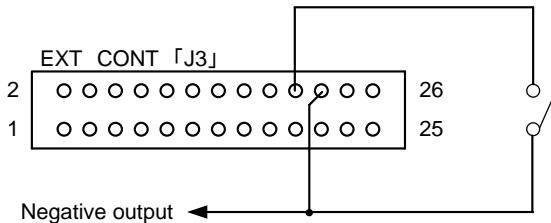

Fig. 5-12 External Alarm Input Terminals

### 5-7-6. Various status signals (CV, CC & ALARM)

It is possible to check the status using the open collector output.

- Constant-voltage (CV) status signal

This status signal goes Low when the PSF-H Series power supply unit enters the constant-voltage (CV) status.

- Constant-current (CC) status signal

This status signal goes Low when the PSF-H Series power supply unit enters the constant-current (CC) status.

- Alarm status signal

This status signal goes Low when the PSF-H Series power supply unit enters the alarm status.

Refer to the specification table below for details about the photo coupler.

PC3H7 made by SHARP

	Item	Symbol	Max. rating	Unit
Output	Collector-emitter voltage	$V_{CEO}$	66	V
	Emitter-collector voltage	$V_{ECO}$	6	V
	Collector current	$I_C$	50	mA
	Collector power dissipation	$P_C$	150	mW
Total power dissipation		$P_T$	170	mW
Isolation voltage		$BV_S$	2500	Vrms

Constant-voltage (CV) status : Pins 23 and 26 (COM)

Constant-current (CC) status : Pins 24 and 26 (COM)

Alarm status : Pins 25 and 26 (COM)

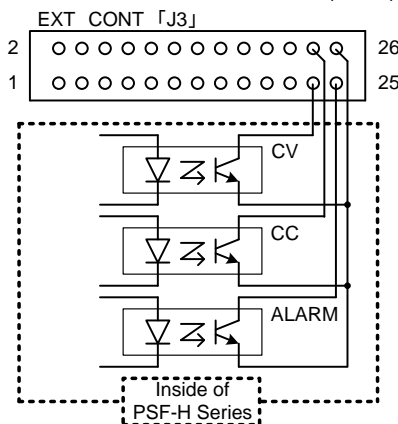
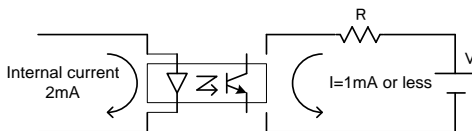

Fig.5-13 Status Terminals



※ Select and use proper voltage or resistance so that the open collector current does not exceed 1mA.

Fig. 5-14 Photo coupler current

## 5-8. Activating output when turning on power

Using the output on/off function with the external contacts shown in Section [“5-7-4. Output ON/OFF with external contacts”](#) it is possible to turn on output automatically as soon as power is input to the power supply unit.

The value stored automatically when the source voltage is cut off or the POWER switch is shut off is output. Check the set value again before using this function.

## 5-9. Usage of sequence Function

Using the sequence function shown in Section [“5-5-4. Sequence function \(04\)”](#)

Using the sequence function shown in Section

- ◆ See Section [“5-5-4. Sequence function \(04\)”](#) above for the procedures of setting the sequence operation.

Download the application software exclusive for the sequence operation from our homepage and create sequence programs in advance.

- (1) Write sequence programs through the interface board.
- (2) Activate the sequence function shown in Section [“5-5-4. Sequence function \(04\)”](#).
- (3) Execute sequence operation with the PRESET key(s).  
Each PRESET key has two functions. Operations caused by pressing the PRESET key and OUTPUT key are different in the normal operation and sequence operation modes. These keys cause the following operations in sequence operation.

Normal operation	Sequence operation
PRESET 1	Starts or gives a pause to operation. ▶/
PRESET 2	Jumps to the step of the number one smaller than the step number. ◀◀
PRESET 3	Jumps to the step of the number one larger than the step number. ▶▶
OUTPUT	Finishes sequence operation.



The OUTPUT key DOES NOT start sequence operation.

Use the PRESET 1 key (▶/|||) to start sequence operation. Even if the sequence function is activated and the SEQUENCE LED is lit, the sequence operation will not start unless the PRESET 1 key (▶/|||) is pressed. Other functions than the preset function work normally even when the SEQUENCE LED is lit. When the OUTPUT key is pressed during sequence operation, sequence operation finishes. Note that completion of sequence operation is different from deactivation of output in normal operation.

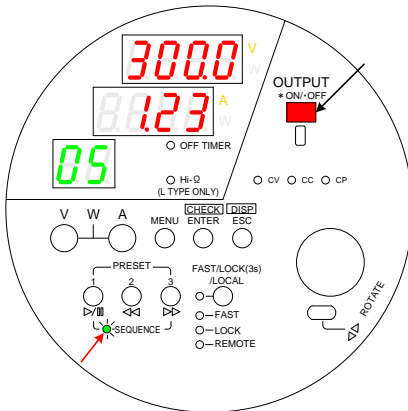
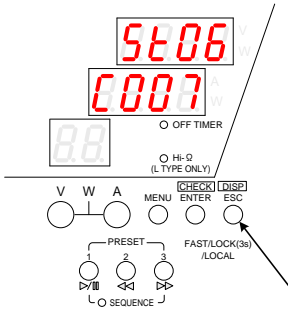

### Operation procedure

Display in sequence operation is different from that in normal operation. It is as shown below. When the ESC/DISP key is pressed in sequence operation, the step number is displayed on the voltage 7-segment LED and the number of cycles is displayed on the current 7-segment LED. Press the ESC/DISP key again to return to the set value display condition (or the output value display condition while output is given).

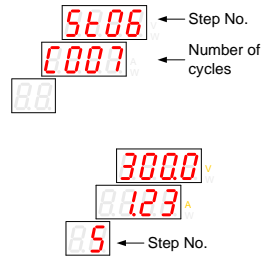

During sequence operation, the SEQUENCE LED below the PRESET key lit, indicating that sequence operation is being executed. To stop sequence operation halfway, press the OUTPUT key or deactivate the sequence function as shown in Section

["5-5-4. Sequence function \(04\)"](#)

## 6. OTHER FUNCTIONS

### 6-1. Display in alarm status

When the PSF-H Series power supply unit enters the alarm status or the function described in Section "5-7-5. Alarm function using external contacts" is used, the alarm code shown below is displayed, indicating that an alarm occurs in the power supply unit. When an alarm occurs, the power supply unit turns off output and stays in the alarm status. When a protection function (excluding OVP and OCP described in Section "5-5-2. OVP/OCP function (02)") works, all operations (panel operation, etc.) are disabled and the power supply unit stops operation.

Press the ESC/DISP key for one second to reset the OVP or OCP alarm (described in Section "5-5-2. OVP/OCP function (02)"). Turn off the input power source or shut off the POWER switch and throw it again to reset the protection function.

Type of alarm	Display	Description	
OVP alarm		This alarm code is displayed if the output voltage exceeds the preset OVP value.	
OCP alarm		This alarm code is displayed if the output current exceeds the preset OCP value.	
OHP alarm		400H 800H	The OHP alarm is displayed if the temperature at the internal detection point exceeds the set temperature. The displayed alarm differs with the models.
		800H	
HARD alarm		Over-voltage (OVP)	Output is turned off if the voltage exceeds 110% of the rated output voltage.
		Over-current (OCP)	Output is turned off if the current exceeds 110% of the rated output current.
		Alarm using external contacts ALARM	Alarm is caused when the contacts are short-circuited. ◆ For details, see section "5-7-5. Alarm function using external contacts" above.

## 6-2. One-Control Parallel Operation

The PSF-H Series power supply units are capable of one-control parallel operation of up to two units, including the master unit. When executing one-control parallel operation using master units, the master and slave units should be set properly in advance.

- ◆ For the setting procedures, see Section [“5-5-7. Master-slave function \(10\)”](#) master-slave function above.

Connect the master and slave units with the optional parallel signal cables OP-22P. Joint kit JK-10 are also available by option. Use these kits as the necessity requires.

The sum of the master unit current and slave unit current is displayed on the master unit.

- ◆ See Section [“2. SPECIFICATIONS”](#) for the displayed items and setting resolution in one-control operation.

The current displayed on the master unit is the sum of the current of the master and slave units.

Output depends on the master unit. When the OUTPUT key of the master unit is thrown, outputs of the slave units are turned on automatically.



Improper wiring or setting may cause failures. Recheck the setting before starting one-control operation.

If the load cables of a slave unit are disconnected, excessive voltage is applied to the slave unit instantaneously and a “HArD” alarm occurs. Check if the cables are connected properly. Repair improper connection. The master unit displays the total current. If the actual value is remarkably different from the set current and/or output current, improper power may possibly be set in the setting shown in Section [“5-5-7. Master-slave function \(10\)”](#) Recheck the set power.

In one-control parallel operation, if there is a large electric potential difference between the output terminals of the master unit and the slave unit (specifically between the negative output terminals), there may be a difference between the actual current value and the current value that is displayed. For operation in a parallel connection, use a cable with the lowest possible impedance for the load line.

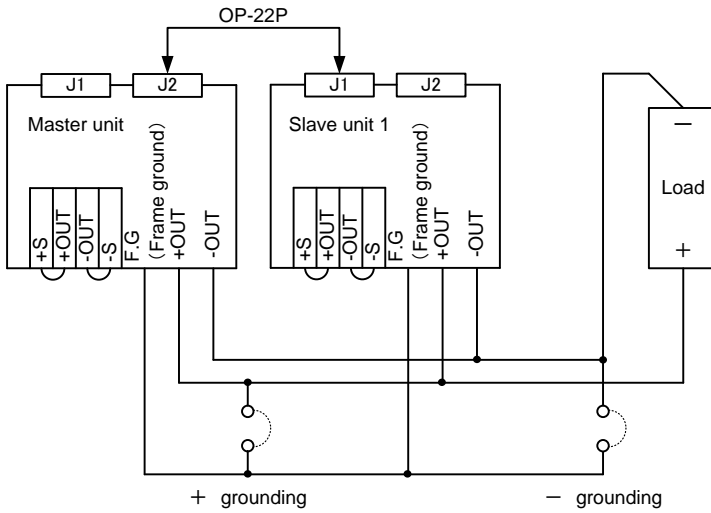

Fig. 6-1 Parallel Connection

## 6-2-1. Master-slave connection using joint kits

The joint kits facilitate master-slave connection of two units and offer sufficient rigidity.

### How to Connect Units Vertically

- (1) Remove the rubber shoes from the bottom of unit A. (Keep the removed rubber shoes and screws with care not to lose them.)
- (2) Fix the joint kit (JK-10) to the top panel of the unit B with the flat countersunk head screws supplied with the kit. (Four positions)
- (3) Place the units as shown in Fig. 6-2 below so that the projections of the JK-10 on the unit B are inserted in the holes in the unit A, from which the rubber shoes are removed above.
- (4) Shift the unit A, and fix the rear panel to the brackets of the joint kit (JK-10) firmly with the screw with washer supplied with the kit. (Two positions)

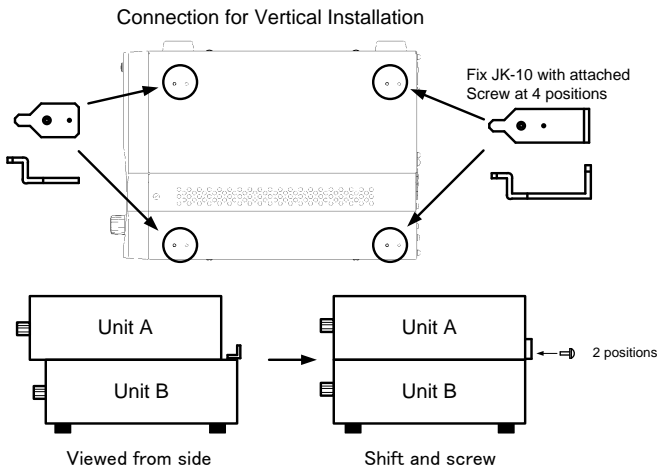

Fig. 6-2 Connection for Vertical Installation

## How to Connect Units Horizontally

- (1) Remove the rubber shoes from the side of unit B. (Keep the removed rubber shoes and screws with care not to lose them.)
- (2) Fix the joint kit (JK-10) to the side with no rubber shoes of the unit B with the flat countersunk head screws supplied with the kit. (Four positions)
- (3) Place the units as shown in Fig. 6-3 below so that the projections of the JK-10 on the unit B are inserted in the holes in the unit A, from which the rubber shoes are removed above.
- (4) Shift the unit A, and fix the rear panel to the brackets of the joint kit (JK-10) firmly with the screw with washer supplied with the kit. (Two positions)

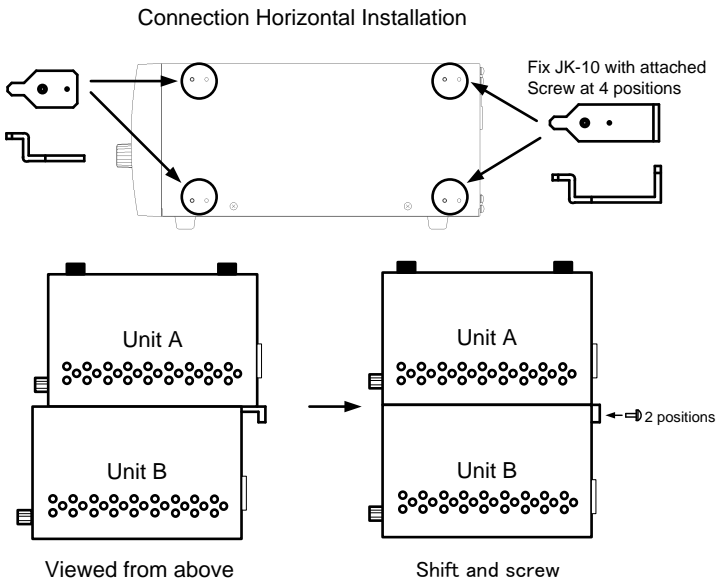
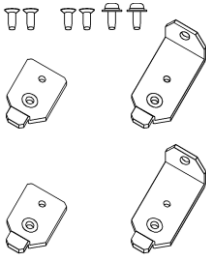

Fig. 6-3 Connection for Horizontal Installation

## 7. OPTION

### 7-1. Accessories

The options shown below are available for the PSF-H Series power supply unit.



JK-10 Joint kit

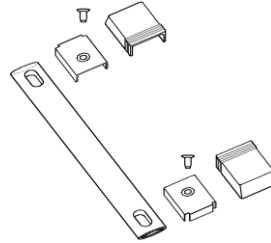

HK-10 Handle kit

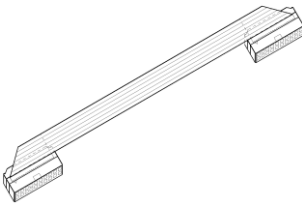

OP-22P Parallel signal cable

### 7-2. Interface Boards

Two types of optional interface boards shown below are available:

- (1) IF-60GP : GP-IB + local bus
- (2) IF-60RU : USB + RS-232C + local bus

# 8. EXTERNAL CONTROL THROUGH INTERFACE BOARD

## 8-1. Remote control

It is possible to control the PSF-H Series power supply unit from a Personal computer or sequencer through communication when the optional interface board is mounted in it. Two types of interface boards IF-60GP and IF-60RU are available for communication with a Personal computer through GP-IB, RS-232C and USB interfaces. These boards enable a maximum of ten units to be connected with the master unit connected with a Personal computer through a local bus. The connected units may be controlled as the slave units.

The terms “master unit” and “slave unit” here are the same as the master and slave unit for power extension described in Section. However, they have different meanings. Do not confuse them.

## 8-2. Interface connectors

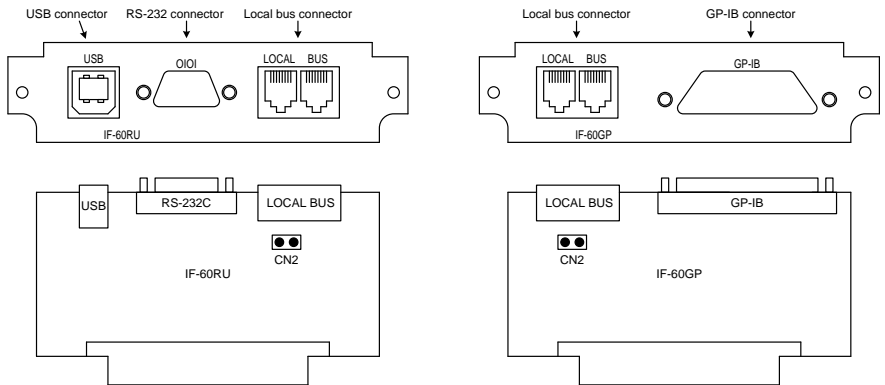

Fig. 8-1 Sketch of Interface Boards



## 8-3. Specifications

### 8-3-1. Specifications of IF-60RU

RS-232C section	
Specifications	Conforms to the RS-232C Standards.
Data transmission speed	57600[bps]
Data bit	Data: 8 [bits], stop bit: 1 [bit], parity: none
Max. cable length	10[m]
Connector type	D-sub, 9-pin, plug
Applicable cable	Mass-marketed interlink cable (Socket 9-pin to socket 9-pin)
Q'ty of connectable units	One-to-one connection only

USB section	
Specifications	Conforms to the USB Standards, Revision .2.0. Full speed: 12 [Mbps]
Connector type	USB series B
Device class	Exclusive device class. Drive for Windows is offered separately.
Vendor code	098F
Product code	1006
Power supply	Self-powered only
Q'ty of connectable units	Maximum of 30 units are connectable through USB hubs.

Local bus section	
Specifications	Conforms to the RS-485 Standards. Exclusive protocol.
Max. cable length	10 [m]
Connector type	RJ-11 (6-pin modular) Pin 2 (D+), pin 3 (D-)
Applicable cable	Exclusive modular cable CB-0603S, -0615S, -0630S & -06100S (Our product Nos.)
Q'ty of connectable units	Maximum of 10 units are connectable through daisy chain connection.
Terminator	Built-in. May be turned on/off with jumper pin.
Q'ty of ports	2 ports, non-directional

### 8-3-2. Specifications of IF-60GP

GP-IB section	
Specifications	Conforms to IEEE488-1978.
Interface functions	SH1, AH1, T6, L4, SR1, RL1, PR0, DC1, DT0, C0, & E1
Address setting	Address between 1 and 30 may be set freely.
Delimiter	LF, EOI, & LF + EOI
Listener function	Output conditions of controlled power supply units may be set.
Talker function	Output conditions and setting conditions of controlled power supply units may be detected.
Service request function	Occurrence of alarms and errors and presence or absence of responses are reported.
Q'ty of connectable units	Maximum of 14 units are connectable with a single GP-IB card.

Local bus section	
Specifications	Conforms to the RS-485 Standards. Exclusive protocol.
Max. cable length	10 [m]
Connector type	RJ-11 (6-pin modular) Pin 2 (D+), pin 3 (D-)
Applicable cable	Exclusive modular cable CB-0603S, -0615S, -0630S & -06100S
Q'ty of connectable units	Maximum of 10 units are connectable through daisy chain connection.
Terminator	Built-in. May be turned on/off with jumper pin.
Q'ty of ports	2 ports, non-directional

※ The IF-60RU and IF-60GP have the same local bus for the slave units, which may be equipped with either type of interface boards.

## 8-4. Connection Methods

Refer to the instruction manual supplied with the interface boards for the mounting method in the PSF-H Series power supply units.

Be sure to confirm that power is off before mounting the interface board for safe operation.

The following shows an example of connecting several PSF-H Series power supply units through the local buses.

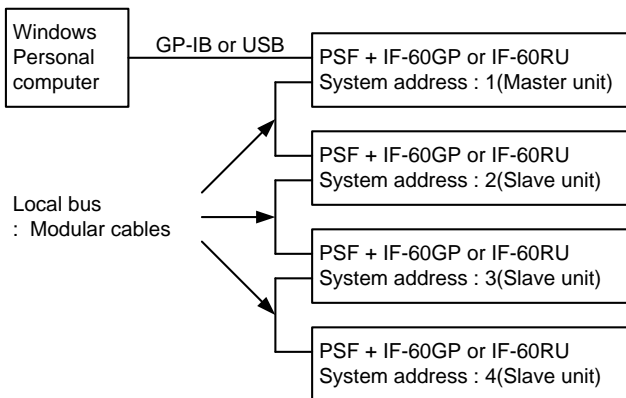

Fig. 8-2 Local bus Connection

The input and output of the interface board need not be discriminated for local bus connection.

Use as short modular cables as possible. Short-circuit the jumper pins (CN2) of the interface units at both ends with the shorting connectors <sup>※1</sup>. Disconnect the shorting connectors from other interface boards <sup>※2</sup>.

<sup>※1</sup> : The interface board is short-circuited with the jumper pin before shipment.

◆ See “[Fig. 8-1 Sketch of Interface Boards](#)” for the CN2.

<sup>※2</sup> : Keep the disconnected connectors in safe without losing them.

Disconnect the CN2 from the interface board of system addresses 2 and 3 in the example shown in Fig. 8-2 Local bus Connection.

## 8-5. Connection cable

- Use the exclusive modular cables for local bus connection.  
(Our product No.:CB-0603S,CB-0615S,CB-0630S & CB-06100S)
- Use GP-IB cables obtainable on the market for GP-IB connection.  
(Our product No.: CB-2420P)
- Use USB cables (applicable to the full speed or superior) obtainable on the market for USB connection.
- Use interlink cables for Personal computers for RS-232C connection.  
The pin assignment is as shown below. Note that the normal cross cables may not be used.

Table 8-1 RS-232C Cable Connection

Personal computer			IF-60RU		
D-Sub 9 pin socket	2	RxD	↔	3	D-Sub 9 pin socket inch threads
	3	TxD	↔	2	
	4	DTR	↔	6	
	5	GND	↔	5	
	6	DSR	↔	4	
	7	RTS	↔	8	
	8	CTS	↔	7	
	FG		↔	FG	

## 8-6. Address Setting

The interface has two addresses: Personal computer address, and system address. It depends on the address whether the unit serves as the master unit connected with a Personal computer or a slave unit connected with the local bus. If the system address of a unit is set to 1, that unit serves as the master unit, whose Personal computer address may be specified. Assign different numbers to all slave units connected with a single master unit.

The system address of the unit directly connected with a Personal computer must be 1. The system operation is not guaranteed if several slave units connected with the master unit have the same system address. Do not assign the same address to several slave units.

Address	Range	Remark
System address	1 to 30	Address 1 is used for the master unit. Other addresses are for the slave units. The slave units connected with a single master unit must have different system addresses.
Personal computer address	1 to 30	The Personal computer address may be set only when the system address is 1. It is the GP-IB address for the GP-IB interface. It is a number for equipment specification for the USB interface. RS-232C uses no Personal computer address.

## Set the system address and/or Personal computer address

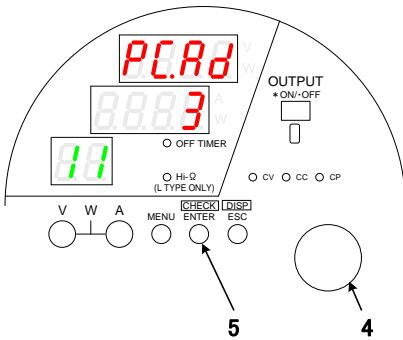
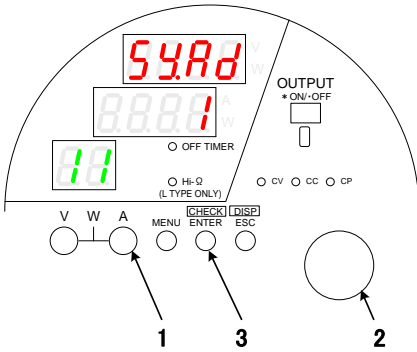

### Operation procedure

1. Turn on the unit while holding the A key.

“Sy.Ad” is displayed on the voltage 7-segment LED, and the address is displayed on the current 7-segment LED.

Keep the A key depressed until “Sy.Ad” is displayed.

The model name and version data are displayed first, and the interface type is displayed.

Then, the system address may be set.

2. Rotate the encoder to select the proper address.
3. Press the ENTER/CHECK key.

The selected system address is validated. A unit whose system address is other than 1 provides normal operation.

When the system address 1 is set, “PC.Ad” is displayed on the voltage 7-segment LED, indicating that a Personal computer address may be set.

4. Rotate the encoder to select the proper address.
5. Press the ENTER/CHECK key, the Personal computer address is validated, and the unit provides normal operation.

The unit stores the system address and Personal computer address, which will remain valid even after power of the unit is turned off until they are changed.

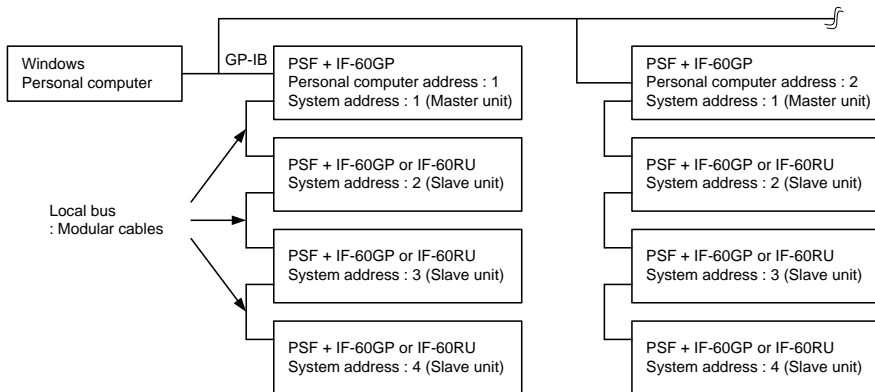

Use the IF-60RU in the master unit when the USB interface is used.

Fig. 8-3 Address Setting Example using GP-IB Interface

## 8-7. Using Interface Boards

### 8-7-1. Using the GP-IB interface

- We checked GP-IB operations using the NATIONAL INSTRUMENTS interface board and provide sample programs. ※<sup>1</sup>  
All interface boards conforming to the IEEE488 Standards will work free from troubles, and the user may use any board. However, it may take long time to provide support or we cannot take proper actions, depending on the types of interface boards. Please note this.
- The IF-60GP accepts the delimiters LF (0×0A), EOI, and LF (0×0A) + EOI. It sends a response in LF (0×0A) + EOI only.
- When using the local bus through GP-IB, control must be returned to the master unit after transferring commands to the slave units ※<sup>2</sup>. Unless control has been returned to the master unit, the GP-IB tool in the Personal computer may fail to recognize the interface board properly.

※<sup>1</sup> : You may download the sample programs from our homepage.

Access to: <https://www.texio.co.jp/>

※<sup>2</sup> : Send ADDR1.

◆ See Section “8-8-32. Local address setting (:ADDR)” below.

### 8-7-2. Using the USB interface

- You may use the USB port of your Personal computer for communication through the USB interface. Microsoft Windows 7 or later version operating systems may be used.
- To use the USB interface, it is necessary to install the exclusive device driver and API. For the installation procedures, refer to the instruction manual of the API. ※<sup>1</sup>
- This driver does not cover the suspension and sleep functions of the Personal computer. It may fail to demonstrate its full performances when the screen saver or other application is running. Please note this.
- The USB hub is easily affected by external noises, which may cause malfunctioning. Utilize self-powered operation as far as possible so that the communication path is not affected by noises.

※<sup>1</sup> : You may download the instruction manual of the API from our homepage.

Access to: <https://www.texio.co.jp/>

### 8-7-3. Using the RS-232C interface

You may use the serial port of your Personal computer or sequencer for communication through the RS-232C interface. The RS-232C interface utilizes the CTS-RTS flow for communication control. If the flow control fails to work properly, some characters may be lost, resulting in malfunctioning. Please note this. Note that the cross cables for Personal computers use different flow control connection and are unusable.

### 8-7-4. Using the local bus

The time-out of communication between the Personal computer and master unit should be longer when the local bus is used. The communication time is influenced by the cable length. Check it and determine the time-out value.



**General description about communication. When you are going to control several PSF-H Series power supply units from a Personal computer, the potential of the frames of the power supply units must be equal to that of the Personal computer frame. If those potentials are different, you may receive electric shocks or the Personal computer may be broken. Be very careful.**

### 8-8. Communication commands

- Every communication command consists of general alphanumeric characters and symbols and has a header, which is the abbreviation of a function. Parameters consist of an integer (NR1) and decimal places (NR2). Parameters following the tenth character are ignored. Decimal places are rounded off according to the actual setting resolution. The response contains no header. Only parameters are sent in response.
- LF (0×0A) is used as the delimiter, which indicates the end of data. Multi-commands consisting of several continuous commands are not applicable to communication of the PSF-H Series power supply unit. Thus, commands must be separated with delimiters. If delimiters are used, the interface unit automatically controls the flow of communication. Communication commands are accepted, whether they are written in capital letters or small letters.
- Use the address command “:ADDR” to specify a system address of the slave unit when communicating with the slave unit in the local bus from the Personal computer. Since address 1 has been set by default, the system address of the master unit is to be specified.
- An error occurs if a command causing a competitive operation is sent while the sequence or external control function is working.



## Command list

Category	Set item	Command	Query	Page	Function
Output setting	Output voltage setting	: VOLT	: VOLT ?	64	25
	OVP setting	: VOLT : PROT	: VOLT : PROT ?	64	30
	Output current setting	: CURR	: CURR ?	64	25
	OCP setting	: CURR : PROT	: CURR : PROT ?	65	30
	Output power setting	: POW	: POW ?	65	25
	Output ON/OFF	: OUTP	: OUTP ?	66	26
Function	Display switch	: CONF : DISP	: CONF : DISP ?	66	14
External control	External control setting	: EXT : MOD	: EXT : MOD ?	66	35,40
	External voltage control	: EXT : VOLT	: EXT : VOLT ?	67	35,42
	External current control	: EXT : CURR	: EXT : CURR ?	67	35,43
	Output switching	: EXT : OUTP	: EXT : OUTP ?	67	37,44
Off timer	Off timer ON/OFF	: TIMER : MOD	: TIMER : MOD ?	68	31
	Off timer value setting	: TIMER : SET	: TIMER : SET ?	68	31
Status check	Monitor request	-----	: MEAS ?	68	41
Preset	Call	: PRES : CALL	: PRES : CALL ?	69	29
	Save	: PRES : SAVE	: PRES : SAVE ?	69	29
Sequence	Sequence mode setting	: SEQ : MOD	: SEQ : MOD ?	69	32
	Jump	: SEQ : STEP	: SEQ : STEP ?	70	32,46
	Start step	: SEQ : START	: SEQ : START ?	70	32,46
	End step	: SEQ : END	: SEQ : END ?	70	32,46
	Repetition number	: SEQ : CYCL	: SEQ : CYCL ?	71	32,46
	Data transfer	: SEQ : DOWNLOAD	: SEQ : DOWNLOAD ?	71	71
Common	Model inquiry	-	* IDN ?	71	71
	ESR query	-	* ESR ?	72	72
	Event enable	* ESE	* ESE ?	72	72
	STB query	-	* STB ?	72	72
	SRQ enable	* SRE	* SRE ?	72	72
	Clear	* CLS	-	72	72
	Reset	* RST	-	72	72
	Completion	* OPC	* OPC ?	73	73
	Wait for completion	* WAI	-	73	73
Extension	Local communication	: ADDR	-	73	54
	Remote mode	: REMOTE	: REMOTE ?	74	54

◆ See the pages shown in "Function" for the explanation of each function.

### 8-8-1. Output voltage setting (:VOLT)

This command sets or inquires about the output voltage.

Setting	:VOLT <value>  The <value> range is from 0.0 to 820.0. One decimal place is valid.	
Application xample	:VOLT 101.0	Sets the output voltage 101.0V.
Query	:VOLT?	Inquires about the set output voltage
Response example	101.0	Indicates that the set output voltage is 101.0V.
Remark	None	

### 8-8-2. OVP setting (:VOLT:PROT)

This command sets or inquires about the OVP (over-voltage protection) value.

Setting	:VOLT:PROT <value>  The <value> range is from 10.0 to 840.0. One decimal place is valid.	
Application example	:VOLT:PROT 101.0	Sets the OVP voltage 101.0V.
Query	:VOLT:PROT?	Inquires about the set OVP value.
Response example	101.0	Indicates that the set OVP value is 101.0V.
Remark	None	

### 8-8-3. Output current setting (:CURR)

This command sets or inquires about the output current.

Setting	:CURR <value>  The <value> range in single-unit operation is as shown below: 0.00 to 3.07 PSF-400H 0.00 to 6.15 PSF-800H Two decimal places are valid. The setting range changes in power extension master-slave (parallel) operation. Resolution in parallel operation: 100mA Setting range: 0.0 to (total current x 1.025)	
Application example	:CURR 1.01	Sets the output current 1.01A.
Query	:CURR?	
Response example	1.01	Indicates that the set output current is 1.01A.
Remark	None	

#### 8-8-4. OCP setting (:CURR:PROT)

This command sets or inquires about the OCP (over-current protection) value.

Setting	:CURR:PROT <value>	
	<p>The &lt;value&gt; range in single-unit operation is as shown below:            0.10 to 3.15 PSF-400H            0.10 to 6.30 PSF-800H</p> <p>Two decimal places are valid.            The setting range changes in power extension master-slave (parallel) operation.            Resolution in parallel operation: 100mA            Setting range: 0.0 to (total current x 1.05)</p>	
Application example	:CURR:PROT 1.01	Sets the OCP value 1.01A.
Query	:CURR:PROT?	
Response example	1.01	Indicates that the set OCP value is 1.01A.
Remark	None	

#### 8-8-5. Output power setting (:POW)

This command sets or inquires about the output power.

Setting	:POW <value>	
	<p>The &lt;value&gt; range in single-unit operation is as shown below:            10 to 410 PSF-400H            10 to 820 PSF-800H</p> <p>The integer is valid.            The setting range changes in power extension master-slave (parallel) operation.            Setting range: 0.0 to (total power x 1.025)</p>	
Application example	:POW 100	Sets the output power of 100W.
Query	:POW?	
Response example	100	Indicates that the set output power is 100W.
Remark	None	

### 8-8-6. OUTPUT ON/OFF (:OUTPUT)

This command turns on or off output.

Setting	:OUTPUT <value>	
	<value> and On/Off is as shown below: 0: Output Off 1: Output On	
Application example	:OUTPUT 1	Activates output.
Query	:OUTPUT?	
Response example	1	Indicates that output is activated. "?" has the same function as <value>
Remark	This command causes an execution error if output is to be set externally.	

### 8-8-7. Display switching (:CONF:DISP)

This command switches the voltage, current and power display modes.

Setting	:CONF:DISP <value>	
	<value> is as shown below: 1: voltage + current display 2: voltage + power display 3: power + current display 7: Sequence or Off Timer display	
Application example	:CONF:DISP 1	Selects the voltage + current display mode.
Query	:CONF:DISP?	
Response example	1	Indicates that the voltage + current display mode is selected. "?" has the same function as <value>.
Remark	The value of 7 causes an error unless the Off Timer or sequence function (Pause, RUN) is working.	

### 8-8-8. External control setting (:EXT:MOD)

This command sets an external control mode.

Setting	:EXT:MOD <value>	
	<value> is as shown below: 0: Setting from the panel or through communication 1: External control with voltage 2: External control with resistance	
Application example	:EXT:MOD 1	Selects the external control with voltage.
Query	:EXT:MOD?	
Response example	1	Indicates that external control with voltage is working. "?" has the same function as <value>.
Remark	This command causes an error during sequence operation (RUN).	

### 8-8-9. External output voltage control ON/OFF (:EXT:VOLT)

This command selects the external output voltage control mode.

Setting	:EXT:VOLT <value>	
	<value> is as shown below: 0: Deactivates external output voltage control. (for control from the panel or through communication) 1: Activates external output voltage control.	
Application example	:EXT:VOLT 1	Selects the external output voltage control.
Query	:EXT:VOLT?	Inquires about the setting.
Response example	1	Indicates that external output voltage control is working. "?" has the same function as <value>.
Remark	This command causes an error during sequence operation (RUN).	

### 8-8-10. External output current control ON/OFF (:EXT:CURR)

This command selects the external output current control mode.

Setting	:EXT:CURR <value>	
	<value> is as shown below: 0: Deactivates external output current control. (for control from the panel or through communication) 1: Activates external output current control.	
Application example	:EXT:CURR 1	Selects the external output current control.
Query	:EXT:CURR?	Inquires about the setting
Response example	1	Indicates that external output current control is working. "?" has the same function as <value>.
Remark	This command causes an error during sequence operation (RUN).	

### 8-8-11. OUTPUT switching (:EXT:OUTP)

This command selects output ON/OFF with external contacts.

Setting	:EXT:OUTP <value>	
	<value> is as shown below: 0: Control from the panel or through communication 1: Output On/Off with external contacts	
Application example	:EXT:OUTP 1	Selects output ON/OFF with external contacts.
Query	:EXT:OUTP?	Inquires about the setting.
Response example	1	Indicates that output On/Off with external contacts is working. "?" has the same function as <value>.
Remark	This command causes an error during sequence operation (RUN).	

### 8-8-12. Off timer ON/OFF (:TIMER:MOD)

This command activates or deactivates the Off Timer.

Setting	:TIMER:MOD <value>	
	<<value> is as shown below: 0: Deactivates the Off Timer. 1: Activates the Off Timer.	
Application example	:TIMER:MOD 1	Activates the Off Timer.
Query	:TIMER:MOD?	Inquires about the setting.
Response example	1	Indicates that the Off Timer is working. "?" has the same function as <value>.
Remark	This command causes an error during sequence operation (RUN).	

### 8-8-13. Off timer value setting (:TIMER:SET)

This command sets or inquires about the Off Timmer value.

Setting	:TIMER:SET <value>	
	The <value> range is between 0.1 and 99.5. Specify the hour in the integer part and minutes in the first decimal place (in units of 10 minutes).	
Applicatuin example	:TIMER:SET 10.3	Set the Off Timer value to 10 hours and 30 minutes.
Query	:TIMER:SET?	Inquires about the setting.
Response example	15.2	Indicates that the Off Timer value is set to 15 hours and 20 minutes.
Remark	This command causes an error during sequence operation (RUN). It also causes an error if a value between 6 and 9 is set the first decimal place.	

### 8-8-14. Monitor inquiry (:MEAS?)

This command inquires about the monitored data. In response, the voltage, current, power and CV/CC/CP status are returned.

Setting	None	
Query	:MEAS?	
Response example	200.0,5.00,100,0	
	Indicates that the output values are 200.0V, 5.00A and 100W and the CV function is working. ※ The voltage, current, power and status are returned in this order. The status is 0 (CV), 1 (CC) or 2 (CP).	
Remark	None	

### 8-8-15. Preset calling (:PRES:CALL)

This command calls and inquires about preset data.

Setting	:PRES:CALL <value>	
	<value> is as shown below: 0: Cancels preset. 1: Calls PRESET 1 data. 2: Calls PRESET 2 data. 3: Calls PRESET 3 data.	
Application example	:PRES:CALL 1	Calls the set values stored in PRESET 1.
Query	:PRES:CALL?	Inquires about the setting.
Response example	1	Indicates that PRESET 1 is selected. "?" has the same function as <value>
Remark	This command causes an error during sequence operation (RUN).	

### 8-8-16. Preset saving (:PRES:SAVE)

This command saves the current set values (voltage, current and power) in PRESET memory.

Setting	:PRES:SAVE <value>	
	<value> is as shown below: 1: Saves the current set value in PRESET 1. 2: Saves the current set value in PRESET 2. 3: Saves the current set value in PRESET 3.	
Application example	:PRES:SAVE 1	Saves the current set values in PRESET 1.
Query	None	
Remark	This command causes an error during sequence operation (RUN).	

### 8-8-17. Sequence mode setting (:SEQ:MOD)

This command sets sequence mode operation.

Setting	:SEQ:MOD <value>	
	<value> is as shown below: 0: Stops sequence operation. 1: Sequence operation – Waits for starting (PAUSE). 2: Sequence operation – Executes (RUN).	
Application example	:SEQ:MOD 2	Executes sequence operation.
Query	:SEQ:MOD?	Inquires about the setting.
Response example	2	Indicates that sequence operation is being executed. "?" has the same function as <value>
Remark	None	

### 8-8-18. Sequence jump setting (:SEQ:STEP)

This command jumps to a specified step of sequence operation.

Setting	:SEQ:STEP <value>  < The <value> range is from 0 to 99. This command is accepted in the wait-for-sequence status (PAUSE) only.	
Application example	:SEQ:STEP 2	Changes the sequence step No. into 2.
Query	:SEQ:STEP?	Inquires about the setting.
Response example	2,1	Indicates that step 2 is selected and the repetition number is 1.
Remarks	This command causes an error during sequence operation (RUN).	

### 8-8-19. Sequence start step setting (:SEQ:START)

This command specifies a start step of sequence operation.

Setting	:SEQ:START <value>  The <value> range is from 0 to 99.	
Application example	:SEQ:START 2	Sets the sequence start step No. to 2.
Query	:SEQ:START?	Inquires about the setting.
Response example	2	Indicates that sequence operation starts from step 2.
Remark	None	

### 8-8-20. Sequence end step setting (:SEQ:END)

This command specifies an end step of sequence operation.

Setting	:SEQ:END <value>  The <value> range is from 0 to 99.	
Application example	:SEQ:END 2	Sets the sequence end step No. to 2.
Query	:SEQ:END?	Inquires about the setting.
Response example	2	Indicates that sequence operation ends at step 2.
Remark	None	



### 8-8-21. Sequence repetition number setting (:SEQ:CYCL)

This command specifies the number of repeating sequence operation.

Setting	:SEQ:CYCL <value>	
	The <value> range is from 0 to 999. When 0 is set, sequence operation is repeated endlessly.	
Application example	:SEQ:CYCL 2	Sets the sequence repetition number to 2.
Query	:SEQ:CYCL?	Inquires about the setting.
Response example	2	Indicates that sequence operation is repeated twice.
Remark	None	

### 8-8-22. Sequence data transfer (:SEQ:DOWNLOAD)

This command transfers the sequence set data.

Setting	:SEQ:DOWNLOAD <value>	
	<value> represents 1609-byte binary sequence set data.	
Application example	:SEQ:DOWNLOAD #6001600······LF	Transfers the 8-byte header of the binary data, 1600-byte actual data, and delimiter data in sequence.
Query	:SEQ:DOWNLOAD?	Requests the sequence data.
Response example	#6001600······LF	1609-byte sequence set data are returned.
Remark	Exclusive application software is available. Use it for setting ※1	

※1 The application software exclusive for sequence operation may be downloaded from our homepage.

### 8-8-23. Model inquiry (\* IDN ?)

This command inquires about the model.

Setting	None. Query only.	
Query	* IDN?	
	The brand name, model name, serial number and version are returned in this order.	
Response example	TEXIO,PSF-400H,0,1.00/V1.00 The serial number is fixed to 0. The version data include the hardware and software versions.	

#### 8-8-24. Event register inquiry ( \* ESR?)

The function of this command is described in “Event register” in the following section.

#### 8-8-25. Event enable register setting( \* ESE)

The function of this command is described in “Event register” in the following section.

#### 8-8-26. Status byte inquiry ( \* STB?)

The function of this command is described in “Status register” in the following section.

#### 8-8-27. SRQ enable register setting ( \* SRE)

The function of this command is described in “Status register” in the following section.

#### 8-8-28. Buffer clear ( \* CLS)

This command clears the buffers.

Setting	* CLS  Clears the send buffer, receive buffer, local bus buffer, command execution buffer, status byte and event register.
Query	None

#### 8-8-29. Communication reset ( \* RST)

This command clears the communication status.

Setting	* RST  Clears the send buffer, receive buffer, local bus buffer, command execution buffer, status byte and event register. Clears the ESE register and SRE register and also clears the talker and listener setting.
Query	None

### 8-8-30. Command completion (\* OPC)

This command notifies of command execution.

Setting	* OPC  Bits 0 of the event status registers are set when the command is executed. SRQ is generated depending on the status of the ESE register and SRE register.
Query	* OPC?  The value "1" is returned when the command is executed.

### 8-8-31. Wait for completion (\* WAI)

This command waits for command completion.

Setting	* WAI  Waits for execution of the following message till completion of the command: This unit accepts overlap commands only. Executes no processing, in particular.
Query	None

### 8-8-32. Local address setting (:ADDR)

This command specifies the address of a slave unit on the local bus.

Setting	:ADDR <value>  The <value> range is from 1 to 30. Specifies the address of a slave on the local bus to be controlled. This command causes no error even if a non-existing system address is specified.
Application example	:ADDR 3                      Sets communication with the power supply unit of system address 3.  :ADDR 1                      Sets communication with the power supply unit of system address 1 (master unit).
Query	None
Remark	The default value is 1 (master unit). Reset <value> to 1 after completion of communication with the local bus.

### 8-8-33. Remote/local setting (:REMOTE)

This command sets or inquires about the remote/local status.

Setting	:REMOTE <value>  <value> is as shown below: 0: Local status (Normal manual operation) 1: Remote status 2: Local lockout remote status (Cannot return to the local status through key operation.)
Application example	:REMOTE 0                      Sets the local status.
Query	:REMOTE?
Response example	1                                      Indicates that the unit is in the remote status. "?" has the same function as <value>
Remark	If this request is sent in the local status, a response is made after the unit enters the remote status. Thus, 1 is returned.

## 8-9. Registers

The PSF-H power supply unit has registers that conform to the status reporting specified in IEEE488.2.

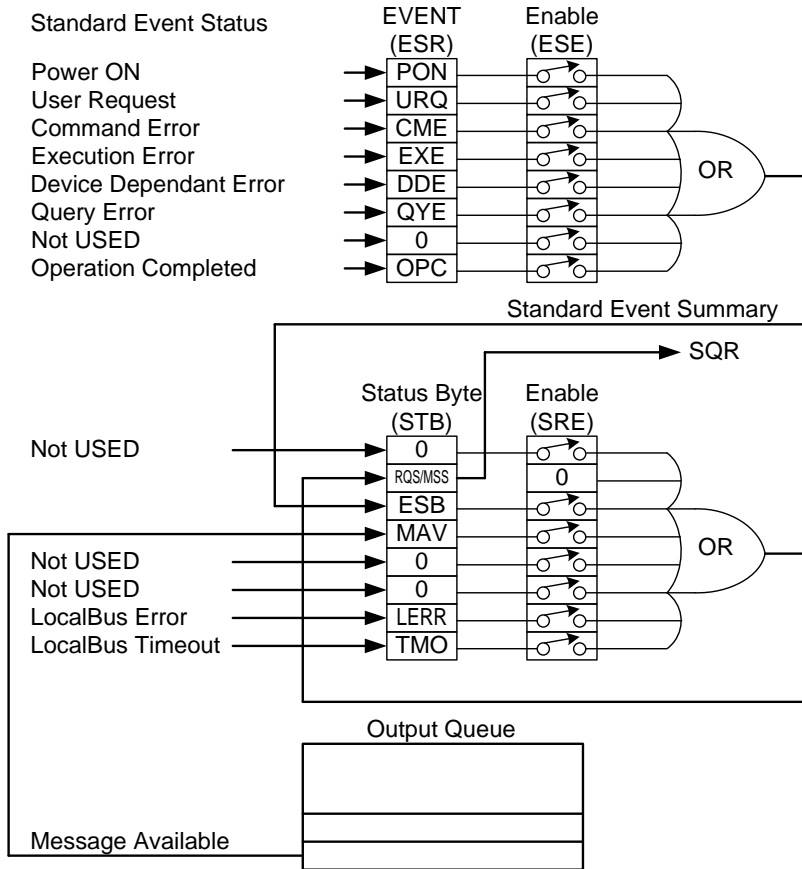

### 8-9-1. Status register (STB, SRE)

bit	Data	Item	Description	Initial STB value	Initial SRE value
7	128	0	Unused.	0	0
6	64	SRQ RQS MSS	Service request Message summary	0	0
5	32	ESB	Standard event summary	0	0
4	16	MAV	Output message available	0	0
3	8	0	Unused.	0	0
2	4	0	Unused.	0	0
1	2	LERR	Local bus error	0	0
0	1	TMO	Local bus Time out	0	0

Each bit is masked when “0” is set in it. (It is the default setting.) Masking is canceled when “1” is set. Set “0” in the unused bits.

Item	Description	
SRQ RQS MSS	MSS is set to 1 when AND of the bits of the status byte, excluding this bit (bit 6), and the service request enable register is 1. RQS is set to 1 when MSS changes from 0 into 1. It is cleared when MSS is cleared or serial polling is executed.	
ESB	Indicates that an event occurs in the standard event status register.	
MAV	Indicates that there is a message in the output queue.	
* SRE	Sets or inquires about the service request enable register.	
	Setting command	* SRE <value> The <value> range is from 0 to 255.
	Application example	* SRE 48 MAV and ESB are enabled since the value is 48 (→ 00110000 in binary)
	Query command	* SRE?
* SRE?	Response example	48 Masking set with this command remains valid until the setting is changed or power is turned off. All bits are masked (0) when power is turned on, regardless of the previous setting.

* STB ?	Reads out the status byte and MSS	
	Setting command	None. Query only.
	Query command	* STB?
	Response example	32 The bits set with the *SRE command are only returned in decimal. The status byte register is not cleared even if an inquiry is made using this command.

## 8-9-2. Event register (ESR, ESE)

The event register is controlled with the \*ESE、\*ESE?、\*ESR?

bit	Data	Item	Description	Initial ESR value	Initial ESE value
7	128	PON	Power On flag	1 (Power ON)	0
6	64	-	Unused.	0	0
5	32	CME	Command error	0	0
4	16	EXE	Execution error	0	0
3	8	ALM	Alarm occurrence	0	0
2	4	-	Unused.	0	0
1	2	-	Unused.	0	0
0	1	OPC	Operation complete	0	0

Item	Description	
* ESE	Sets or inquires about the standard event status enable register.	
	Setting command	* ESE <value> The <value> range is from 0 to 255.
	Application example	* ESE 48 CME and EXE are enabled.
	Query command	* ESE?
	Response example	48 Masking set with this command remains valid until the setting is changed or power is turned off. All bits are masked (0) when power is turned on, regardless of the previous setting.
* ESR ?	Inquires about the standard event status.	
	Setting command	None. Query only.
	Query command	* ESR?
	Response example	32 A command error takes place. ESR is cleared after reading the value.

### 8-9-3. Function of the status byte

If some event occurs and some bit of the status byte is set to 1, bit 6 is set to 1 and a service request (SRQ) is issued. Four status bits shown below may possibly be the causes of an SRQ in the PSF-H Series power supply unit.

Bit 5	ESB	Standard event status register summary
Bit 4	MAV	Message available
Bit 1	LERR	Local bus execution error
Bit 0	TMO	Local bus time-out

If an execution error occurs, bit 4 of the standard event status register (ESR) is set to 1. When AND of the ESR and standard event status enable register (ESE) is 1, bit 5 (ESB) of the status byte is set to 1. If bit 5 of the service request enable register (SRE) is 1 at this time, bit 6 (MSS) of the status byte is set to 1 and a service request (SRQ) is sent to the controller.

NOTE: An SRQ is issued through the GP-IB interface only.

### 8-9-4. Reading data from the status byte and clearing the status byte

Data of the status byte may be read out from the controller in the following two ways:

- Inquiry with the \*STB? query  
When an inquiry is made with the \*STB? query, MSS is read out of bit 6.  
No bits of the status byte are cleared after reading it.
- Serial polling  
When serial polling is executed, RQS is read out of bit 6. RQS is only cleared after reading it. It is impossible to read MSS.  
It is impossible to clear the status byte directly. It is necessary to clear the event register or the like that is the cause of the status byte.
- When ESB occurs  
When an inquiry is made with \*ESR?, data of the standard event register are read out and all bits are cleared then.
- When the \*CLS command is received.  
When receiving the \*CLS command, the PSF-H Series power supply unit clears the standard event register and status byte.
- When MAV occurs  
The MAV bit is cleared when data are read out from the output queue completely. The output queue is not cleared by the \*CLS command.  
When the event register and MAV are cleared completely, MSS in bit 6 is also cleared.



## 8-9-5. Clear and reset statuses

It is possible to cause clearing or resetting in the PSF-H Series power supply unit by issuing commands or executing specific operations.

### **IFC (Interface clear)**

Responses to the universal command IFC are as shown below:

- The specified talker or listener status is cleared.
- The GP-IB buffer, output queue and standing-by command remain unchanged.
- The SRQ remains unchanged.
- The remote status and LLO setting remain unchanged.
- Panel setting remains unchanged.

### **DCL/SDC (Device clear)**

Responses to the universal command DCL and address command SDC are as shown below:

- The GP-IB buffer, output queue and standing-by command are cleared.
- The interface status (specified talker or listener status) is cleared.
- The SRQ and status byte are cleared.
- The remote status and LLO setting are cleared and the power supply unit enters the local state.
- Panel setting remains unchanged.

### **\*RST (Reset command)**

Responses to the IEEE488.2 command \*RST are as shown below:

- The specified talker or listener status is cleared.
- The GP-IB buffer, output queue and standing-by command are cleared.
- The SRQ, status byte and mask setting are cleared.
- The remote status and LLO setting remain unchanged.
- Panel setting remains unchanged.

### **Turning on power again**

When power is turned on again, the statuses are as shown below:

- The specified talker or listener status is cleared.
- The GP-IB buffer, output queue and standing-by command are cleared.
- The SRQ, status byte and mask setting are cleared.
- The unit enters the local status.  
LLO set before turning off power is cleared.
- Panel setting at the time when power is turned off remains unchanged.

### 8-9-6. Remote/local function

The remote/local function is controlled by the system controller and with the FAST key of the PSF-H Series power supply unit. (This key serves as the FAST, LOCK and LOCAL keys.) The PSF-H Series power supply unit always resides in the local, remote, or remote with local lockout status.

#### Local

The PSF-H Series power supply unit enters the local status in either of the following cases:

- When power is turned on.
- When the FAST key is pressed and the LED on the side of key is turned off.
- When the unit receives the GTL command.
- When the remote status is canceled.

#### Remote

The PSF-H Series power supply unit enters the remote status when it is specified as the listener in the condition where REN is true. The LED enters the remote display mode, where any other panel keys than the POWER switch and FAST key are inoperative. In the local lockout status, any other keys than the POWER switch are inoperative, with the only exception of an error.

### 8-9-7. Responses to multi-line message commands

The table below shows the types of multi-line message commands and the responses to the commands.

Type	Name	Description	Response
Universal commands	DCL	Clears the GP-IB buffer.	○
	SPE	Establishes the serial polling state.	○
	SPD	Clears serial polling.	○
	PPU	Clears parallel polling.	×
	LLO	Brings all devices into the local lockout status to disable manual operation.	○
Address commands	UNL	Cancel the specified listener status.	○
	UNT	Cancel the specified talker status.	○
	SDC	Clears the GP-IB buffer.	○
	PPC	Enables parallel polling line assignment to the specified listener in parallel polling.	×
	GTL	Brings a specified device into the local status.	○
	GET	Triggers a specified device.	×
	TCT	Transfers the controller.	×

## 9. TROUBLESHOOTING

This section shows the typical phenomena that imply troubles.

Some phenomena may be solved by rechecking or in simple manner. Contact the nearest our distributor for phenomena that rechecking or countermeasures may not eliminate or improve. Never detach the case to check the inside.

Phenomenon	Possible cause	Check & countermeasures
Power is not turned on even by throwing the POWER switch.	<ul style="list-style-type: none"> <li>• AC power cable is broken or has poor contact.</li> <li>• Input fuse has blown.</li> </ul>	<ul style="list-style-type: none"> <li>• Check connection or replace the cable.</li> <li>• Input voltage is out of the allowable range.</li> </ul>
“----” is displayed after starting operation.	The unit is specified as a slave unit.	<ul style="list-style-type: none"> <li>◆ Specify the unit as the master unit. See Section <a href="#">“5-5-7. Master-slave function (10)”</a></li> </ul>
“OHP” is displayed after starting operation.	The OHP function works.	Check the ambient temperature, air intake and exhaust ports and dust filter.
Display disappears in short time after starting operation.	The fan is stopping.	Check the fan.
No output is given even when the OUTPUT key is pressed.	<ul style="list-style-type: none"> <li>• The set voltage is “0V”.</li> <li>• The set current is “0A”. (In the CC status)</li> <li>• On/Off with the external contacts is selected.</li> <li>• Keys are locked.</li> </ul>	<ul style="list-style-type: none"> <li>◆ See Section <a href="#">“5-4-3. How to set voltage”</a></li> <li>◆ See Section <a href="#">“5-7-2. Set voltage with external voltage or resistance”</a></li> <li>◆ See Section <a href="#">“5-4-4. How to set current”</a></li> <li>◆ See Section <a href="#">“5-7-3. Set current with external voltage or resistance”</a></li> <li>◆ See Section <a href="#">“5-7-4. Output ON/OFF with external contacts”</a></li> <li>◆ See Section <a href="#">“5-4-8. How to invalidate on-panel operations (Key lock function)”</a></li> </ul>
“OVP” is displayed when the OUTPUT key is pressed.	<ul style="list-style-type: none"> <li>• The OVP value is too low.</li> <li>• The sensing wire(s) is/are disconnected.</li> </ul>	<ul style="list-style-type: none"> <li>◆ See Section <a href="#">“5-5-2. OVP/OCP function (02)”</a></li> <li>◆ See Section <a href="#">“5-6. Output Voltage Remote Sensing”</a></li> <li>◆ See Section <a href="#">“5-7-2. Set voltage with external voltage or resistance”</a></li> </ul>
“OCP” is displayed when the OUTPUT key is pressed.	• The OCP value is too low.	<ul style="list-style-type: none"> <li>◆ See Section <a href="#">“5-5-2. OVP/OCP function (02)”</a></li> </ul>
Cannot raise the current up to the set current value.	CP (constant-power) operation is carried out, or the CP value is too low.	<ul style="list-style-type: none"> <li>◆ See Section <a href="#">“5-4-5. How to set power”</a></li> </ul>
Output is unstable.	Oscillating due to influences of the load.	<ul style="list-style-type: none"> <li>• Twist the load or sensing wires, or change the wire layout.</li> <li>• Connect a capacitor at the output end of the power source or the load end.</li> </ul>

# 10. MAINTENANCE

The PSF-H Series power supply unit employs a fan for forced cooling. Clean the dust filter inside the front grill periodically to maintain the cooling efficiency. Pull the front grill while pressing the notch in the upper part to detach the grill. Clean the filter with water. Before starting cleaning, shut off the POWER switch without fail and disconnect the AC power cable to turn off the unit.



**Dry the filter completely before attaching it.  
Water remaining in the filter may cause troubles.**

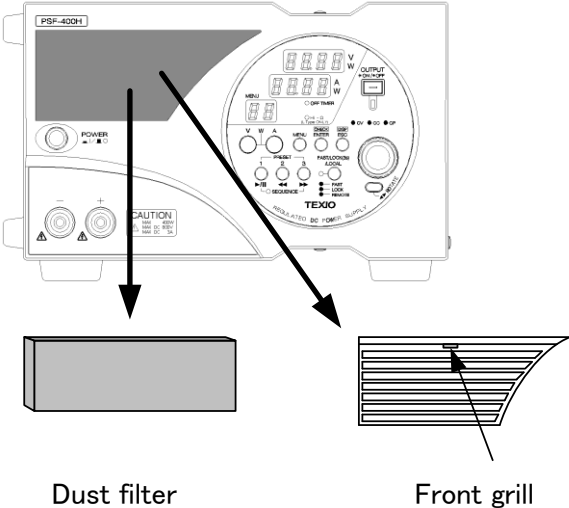

- ② Remove the dust filter
- ① Pull frontward while pressing here

Fig. 10-1 Dust Filter Removal

# 11. OUTSIDE DIMENSIONS

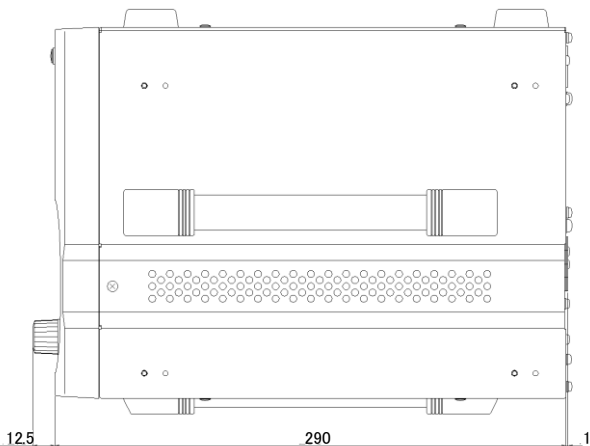
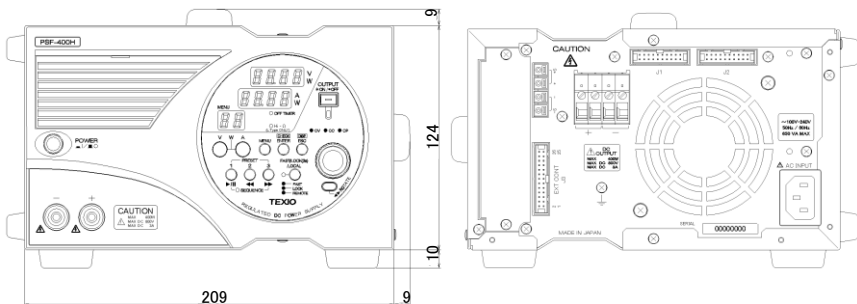

※ The handle is available by option

Fig. 10-2 Outside Dimension of PSF-H



**TEXIO TECHNOLOGY CORPORATION**

7F Towa Fudosan Shin Yokohama Bldg.

2-18-13, Shin Yokohama, Kohoku-ku, Yokohama, Kanagawa, 222-0033 Japan

<https://www.texio.co.jp/>

---