

INSTRUCTION MANUAL

REGULATED DC POWER SUPPLY PA-B SERIES

PA10-5B	PA18-1.2B	PA18-2B
PA18-3B	PA18-5B	PA36-1.2B
PA36-2B	PA36-3B	PA80-1B
PA120-0.6B	PA160-0.4B	PA250-0.25B
PA250-0.42B	PA350-0.2B	PA600-0.1B

CONTENTS

USING THE PRODUCT SAFELY	I - V
1. OUTLINE AND FEATURES	1
2. SPECIFICATIONS.....	2
3. INSTRUCTIONS ON USE	10
3-1. Checking Source Voltage.....	10
3-2. Connection of Power Cable.....	10
3-3. Precautions for Connecting Output Terminals	10
3-4. Switches on Front Panel and Connection Terminals on Rear Panel....	11
3-5. Digital Display	11
3-6. Switching Points of Relay.....	11
3-7. Installation Environments	12
3-8. Rack Mounting	13
3-9. Options	14
4. PANEL EXPLANATION	15
4-1. Front panel.....	16
4-2. Rear panel	19
5. OPERATION PROCEDURES	21
5-1. Independent Operation.....	21
5-2. Remote Sensing.....	21
5-3. OVP.....	22
5-4. Remote Control Functions.....	23
5-5. Output ON/OFF Remote Control.....	25
5-6. Constant-Voltage Remote Control.....	26
5-7. Constant-Current Remote Control.....	29
5-8. Status Signals	32
5-9. Monitoring Voltage and Current.....	33
5-10. Series and Parallel Connections	34
5-11. One-Control Parallel Operation.....	36
5-12. Recharging Battery.....	38
6. TROUBLES AND PHENOMENA.....	39
7. EXTERNAL DIMENSIONS FIGURE	40

This instruction manual applies to fifteen models: PA10-5B, PA18-1.2B, PA18-2B, PA18-3B, PA18-5B, PA36-1.2B, PA36-2B, PA36-3B, PA80-1B, PA120-0.6B, PA160-0.4B, PA250-0.25B, PA250-0.42B, PA350-0.2B, and PA600-0.1B.

The operation procedures, etc. described in this manual are common to all models, except some difference in the specifications. Please refer to the descriptions about the purchased model.

USING THE PRODUCT SAFELY

■ Preface

To use the product safely, read this manual to the end. Before using this product, understand how to correctly use it.

If you read this manual but you do not understand how to use it, call the company that is indicated on the back cover of this manual. After you read this manual, keep it so that you can read it anytime as required.



■ Notes on reading this manual

The contents of this manual include technical terms in part of their explanation.

If you do not understand those terms, do not hesitate to ask the company or each distributor.

■ Pictorial indication and warning character indication

This manual and product show the warning and caution items required to safely use the product. The following pictorial indication and warning character indication are provided.

<p><Pictorial Indication></p> 	<p>Some part of this product or the manual may show this pictorial indication. In this case, if the product is incorrectly used in that part, a serious danger may be brought about on the user's body or the product. To use the part with this pictorial indication, be sure to refer to this manual.</p>
<p><Warning character Indication></p> <p> WARNING</p> <p> CAUTION</p>	<p>If you use the product, ignoring this indication, you may get killed or seriously injured. This indication shows that the warning item to avoid the danger is provided.</p> <p>If you incorrectly use the product, ignoring this indication, you may get slightly injured or the product may be damaged. This indication shows that the caution item to avoid the danger is provided.</p>

Please acknowledge beforehand that our company does not assume the responsibility at all except when the liability for damage in the law is admitted for the user or the third person's misuse, abuse, neglect, unauthorized product modification or failure to follow this manual, and other troubles, or any damages caused by use of this product.

USING THE PRODUCT SAFELY



WARNING

■ Do not remove the product's covers and panels

Never remove the product's covers and panels for any purpose. Otherwise, electric shock to the users or a fire may be incurred.

■ Warning on using the product

The warning items given below are to avoid danger to the user's body and life and avoid the damage and deterioration of the product. Use the product, observing the following warning and caution items.

■ Warning item on installation environment

● Operating temperature

Use the product within the operating temperature indicated in the rating column. If the product is used with the vents of the product blocked or in high ambient temperatures, a fire may occur.

● Operating humidity

Use the product within the operating humidity indicated in the rating column. Watch out for condensation by a sharp humidity change such as transfer to a room with a different humidity. Also, do not operate the product with wet hands. Otherwise, an electric shock or fire may occur.

● Use in a gas

Use in and around a place where an inflammable or explosive gas or steam is generated or stored may result in an explosion and fire. Do not operate the product in such an environment. Also, use in and around a place where a corrosive gas is generated or spreading causes a serious damage to the product. Do not use the product in such an environment.

● Do not let foreign matter in

Do not insert metal and flammable materials into the product from its vent and spill water on it. Otherwise, an electric shock and fire may occur.

USING THE PRODUCT SAFELY



WARNING

■ Warning about Power Source

● Input Power

Check the source voltage before using the PA-B series. The product has an input voltage selector switch above the AC inlet on the rear panel. The figure below shows the source voltage of the PA-B series. Note that using the PA-B series on different voltage may result in a trouble or breakdown. Check the switch, and connect the power cable to the AC outlet.



● Power Cable

IMPORTANT: The power cable set supplied with the PA-B series is unusable for any other product.

Using a power cable not supplied with the PA-B series may result in electric shocks, electrocution or a fire. If the power cable set supplied with the PA-B series is damaged, stop using the PA-B series and contact our distributor. Using the PA-B series with the damaged power cable may result in electric shocks, electrocution or a fire. The power cable set supplied with the PA-B series is to be used for 220 VAC power. Contact the distributor if you intend to use the PA-B series on input voltage other than 220 VAC.

● The fuse for protection

The product doesn't operate when the fuse for input protection is blown. Users can replace the fuse by themselves according to some instructions including cautions and remarks on the user's manual. It is important to be very careful to keep the instructions strictly without fail. Misplacing may cause danger of fire.

USING THE PRODUCT SAFELY



WARNING

■ Warning item on grounding

The product has the GND terminal on the panel surface to protect the user from electric shock and protect the product. Be sure to ground the product to safely use it.

■ Warning item on abnormality while in use

If smoke or fire is generated from the product while in use, stop using the product, turn off the switch, and remove the power cord plug from the outlet. After confirming that no other devices catch fire, call the company or our distributor.



CAUTION

■ Connection of Remote Control Input and Output Terminals

*The maximum input rating of the remote control input and output terminals is determined in order to avoid damages to the product. Do not input or output voltage/current exceeding the rating described in the instruction manual. Excessive input or output may cause a trouble or breakdown of the product.

*When the voltage or current is controlled according to external voltage, the negative (-) side of the external voltage unit is connected with the -S output terminal of the PA-B series. Use the output circuit of the external voltage unit in the condition where it is floated from the frame in order to avoid accidents or malfunctioning.

When several power supply units are used for a remote control application, each external power supply unit must be floated.

*The negative (-) side of the voltage/current monitor terminal is internally connected with the -S terminal. Use the input circuit of the external measuring instrument in the condition where it is floated from the frame in order to avoid accidents or malfunctioning.

USING THE PRODUCT SAFELY



CAUTION

■ Input/output terminal

Maximum input to the input terminals is specified to prevent the product from being damaged.

Do not supply input, exceeding the specifications that are indicated in the "Rating" or "Caution on use" column in this manual of the product. Otherwise, a product failure is caused.

Also, do not supply power to the output terminals from the outside. Otherwise, a product failure is caused.

■ When the product is left unused for a long time

Be sure to remove the power plug from the outlet.

<Calibration>

Although the performance and specifications of the product are checked under strict quality control during shipment from the factory, they may slightly change because of secular changes in its parts. It is recommended to periodically calibrate the product so that it is used with its performance and specifications stable. For consultation about the product calibration, call the distributor or the company where you bought the product.

<Daily maintenance>

When you clean off the dirt of the product covers, panels, and knobs, avoid solvents such as thinner and benzene. Otherwise, paint may peel off or the resin surface may be affected.

To wipe off the covers, panels, and knobs, use a soft cloth with neutral detergent in it.

During cleaning, be careful that water, detergents, and other foreign matters do not get into the product.

If a liquid or metal gets into the product, an electric shock and fire are caused. During cleaning, remove the power cord plug from the outlet.

Use the product correctly and safely, observing the above warning and caution items.

Because this manual indicates caution items even in individual items, observe those caution items to correctly use the product.

If you have questions or comments about the content of this manual, call the distributor or the company.

1. OUTLINE AND FEATURES

The PA-B series is a high-performance DC constant-voltage, constant-current power supply unit with 3 1/2-digit voltage indicator LEDs and 3-digit current indicator LEDs. The series regulator control allows the user to vary the output from 0 to the rated output. The output controller, a 10-turn winding type variable resistor, offers fine control of output voltage and current. It is possible to set the output voltage and current even when the output is off. The output voltage and current may be checked on digital indicators simultaneously. The PA-B series are high-cost-performance power supply units with output On/Off, output sensing and various remote control functions and fully meet various users' needs. They have a wide variety of applications such as power supplies for researches and development, power supplies for aging, and fixed power supplies for many systems according to purposes.

- Low-Ripple and Low-Noise Power Supply Unit

The series regulator control system eliminates ripples and noises to quite low levels and provides low temperature coefficient and superior electrical performances.

- Simultaneous Voltage and Current Digital Display LEDs

3 1/2-digit automatic-range voltage indicator LEDs (fixed range indicators on the PA18-1.2B, PA18-2B, PA18-3B, PA18-5B, PA120-0.6B and PA160-0.4B) and 3-digit current indicator LEDs enable simultaneous check and setting of the voltage and current. The LEDs give indications in green in the constant-voltage mode and in red in the constant-current mode.

- Increased Output in Series/Parallel Operation

Series connection increases the output voltage (except the PA350-0.2B, and PA600-0.1B). Parallel connection increases the output current. One-control parallel connection allows control of several slave power supply units from a single master power supply unit.

- With Floating Output/Voltage Remote Sensing Terminal

The output terminal is a floating type terminal and may be used in the positive or negative polarity. A voltage remote sensing terminal is provided on the front panel for fine control of the load terminal voltage (except the PA80-1B, PA120-0.6B, PA160-0.4B, PA250-0.25B, PA250-0.42B, PA350-0.2B and PA600-0.1B).

- Various Remote Control Terminals for Systematization

The PA-B series have various remote control terminals, which allow the output to be turned on or off or fixed using external contact signals and the output voltage or current to be remote-controlled according to external voltage (0 to 10 V) or input resistance (0 Ω to 10 k Ω).

2. SPECIFICATIONS

Item	PA10-5B	PA18-1.2B	PA18-2B	PA18-3B	PA18-5B	PA36-1.2B	PA36-2B	PA36-3B	
OUTPUT									
Output voltage	0 to 10V	0 to 18V				0 to 36V			
Resolution (logical value)	1.8mV	3.3mV				6.5mV			
Voltage setting dial	10 Rotary								
Output current	0 to 5A	0 to 1.2A	0 to 2A	0 to 3A	0 to 5A	0 to 1.2A	0 to 2A	0 to 3A	
Resolution (logical value)	0.9mA	0.3mA	0.4mA	0.6mA	0.9mA	0.3mA	0.4mA	0.6mA	
Current setting dial	10 Rotary								
CONSTANT VOLTAGE CHARACTERISTICS (CV)									
Input regulation	For $\pm 10\%$ variance of source voltage ^{*1}	1mV	1mV			2mV			
Load regulation	For 0V to 100% variance of output current ^{*1}	5mV	2mV	2.5mV	3mV	5mV	2mV	3mV	4mV
Ripple and noise	rms(10Hz to 1MHz) ^{*2}	0.5mV							
Transient response	typ(current 10% to 100%) ^{*3}	50us typ							
Temperature coefficient	typ	100ppm/°C typ							
Rise time	Full load/No load typ	100ms/100ms							
Fall time	Full load/No load typ	50ms/1s							
Remote control	External voltage/output voltage ratio	Approx. 10V/10V	Approx. 10V/18V			Approx. 10V/36V			
Remote control	External resistance/output voltage ratio	Approx. 10kΩ/10V	Approx. 10kΩ/18V			Approx. 10kΩ/36V			

Item		PA80-1B	PA120-0.6B	PA160-0.4B	PA250-0.25B	PA250-0.42B	PA350-0.2B	PA600-0.1B	
OUTPUT									
Output voltage		0 to 80V	0 to 120V	0 to 160V	0 to 250V		0 to 350V	0 to 600V	
Resolution (logical value)		14.4mV	21.6mV	28.8mV	45.0mV		63.0mV	108.0mV	
Voltage setting dial		10 Rotary							
Output current		0 to 1A	0 to 600mA	0 to 400mA	0 to 250mA	0 to 420mA	0 to 200mA	0 to 100mA	
Resolution (logical value)		180uA	108uA	72uA	45uA	76uA	36uA	18uA	
Current setting dial		10 Rotary							
CONSTANT VOLTAGE CHARACTERISTICS (CV)									
Input regulation	For $\pm 10\%$ variance of source voltage ^{*1}	5mV	7mV	8mV	15mV		20mV	30mV	
Load regulation	For 0V to 100% variance of output current ^{*1}	5mV	7mV	8mV	15mV		20mV	30mV	
Ripple and noise	rms(10Hz to 1MHz) ^{*2}	1mV	1.2mV	1.6mV	2.5mV		3.5mV	5mV	
Transient response	typ(current 10% to 100%) ^{*3}	50us typ							
Temperature coefficient	typ	100ppm/°C typ							
Rise time	Full load/No load typ	100ms/100ms	150ms/150ms		190ms/190ms		200ms/200ms	330ms/330ms	
Fall time	Full load/No load typ	50ms/1s							50ms/1.5s
Remote control	External voltage/output voltage ratio	Approx. 10V/80V	Approx. 10V/120V	Approx. 10V/160V	Approx. 10V/250V		Approx. 10V/350V	Approx. 10V/600V	
Remote control	External resistance/output voltage ratio	Approx. 10kΩ/80V	Approx. 10kΩ/120V	Approx. 10kΩ/160V	Approx. 10kΩ/250V		Approx. 10kΩ/350V	Approx. 10kΩ/600V	

Item	PA10-5B	PA18-1.2B	PA18-2B	PA18-3B	PA18-5B	PA36-1.2B	PA36-2B	PA36-3B		
CONSTANT-CURRENT CHARACTERISTICS (CC)										
Input regulation	For $\pm 10\%$ source voltage fluctuation ^{*1}	2mA								
Load regulation	For 0V to 100% variance of output voltage ^{*1}	5mA	5mA		5mA	5mA	5mA			
Ripple and noise	rms (10 Hz to 1 MHz) ^{*2}	5mA	1mA		5mA	1mA	2mA			
Temperature coefficient	typ	250ppm/°C typ								
Remote control	External voltage to output current ratio	Approx. 10 V/5 A	Approx. 10 V/1.2A	Approx. 10 V/2 A	Approx. 10 V/3 A	Approx. 10 V/5 A	Approx. 10 V/1.2A	Approx. 10 V/2 A	Approx. 10 V/3 A	
Remote control	External resistance to output current ratio	Approx. 10 k Ω /5 A	Approx. 10k Ω /1.2A	Approx. 10 k Ω /2 A	Approx. 10 k Ω /3 A	Approx. 10 k Ω /5 A	Approx. 10k Ω /1.2A	Approx. 10 k Ω /2 A	Approx. 10 k Ω /3 A	
Constant-voltage operation display	Off when output is off	CV (green LED) is on.								
Constant-current operation display	Off when output is off	CC (red LED) is on.								
DIGITAL METER DISPLAY										
Voltmeter display	3 1/2-digit LEDs, red	19.99 V max., fixed range					19.99V/199.9V max., auto range			
Accuracy	Output on	$\pm(0.2\% \text{ rdg} + 1 \text{ digit})$, 23 $\pm 5^\circ\text{C}$, 80%RH or less								
Ammeter display	3-digit LEDs, red	9.99 A max., fixed range								
Accuracy	Output on ^{*4}	$\pm(1.0\% \text{ rdg} + 2 \text{ digits})$, 23 $\pm 5^\circ\text{C}$, 80%RH or less								
Sampling rate		Approx. 2.5 times/sec. or more								

Item		PA80-1B	PA120-0.6B	PA160-0.4B	PA250-0.25B	PA250-0.42B	PA350-0.2B	PA600-0.1B
CONSTANT CURRENT CHARACTERISTICS (CC)								
Input regulation	For $\pm 10\%$ source voltage fluctuation ^{*1}	2mA	1mA		0.5mA	1mA	0.5mA	
Load regulation	For 0V to 100% variance of output voltage ^{*1}	5mA	5mA		5mA	5mA	5mA	2.5mA
Ripple and noise	rms(10Hz to 1MHz) ^{*2}	2mA	1mA					
Temperature coefficient	typ	250ppm/°C typ	200ppm/°C typ			250ppm/°C typ	200ppm/°C typ	
Remote control	External voltage to output current ratio	Approx. 10V/1A	Approx. 10V/0.6A	Approx. 10V/0.4A	Approx. 10V/0.25A	Approx. 10V/0.42A	Approx. 10V/0.2A	Approx. 10V/0.1A
Remote control	External resistance to output current ratio	Approx. 10k Ω /1A	Approx. 10k Ω /0.6A	Approx. 10k Ω /0.4A	Approx. 10k Ω /0.25A	Approx. 10k Ω /0.42A	Approx. 10k Ω /0.2A	Approx. 10k Ω /0.1A
Constant-voltage operation display	Off when output is off	CV (green LED) is on.						
Constant-current operation display	Off when output is off	CC (red LED) is on.						
DIDITAL METER DISPLAY								
Voltmeter display	3 1/2-digit LEDs, red	199.9/999 V max., auto range	199.9 V max., fixed range		199.9/999 V max., auto range			
Accuracy	Output on	$\pm(0.2\% \text{ rdg} + 1 \text{ digit})$, 23 $\pm 5^\circ\text{C}$, 80%RH or less	$\pm(0.2\% \text{ rdg} + 2 \text{ digit})$, 23 $\pm 5^\circ\text{C}$, 80%RH or less					
Ammeter display	3-digit LEDs, red	9.99A max., fixed range	999mA max., fixed range					
Accuracy	Output on ^{*4}	$\pm(1.0\% \text{ rdg} + 2 \text{ digit})$, 23 $\pm 5^\circ\text{C}$, 80%RH or less	$\pm(1.0\% \text{ rdg} + 3 \text{ digit})$, 23 $\pm 5^\circ\text{C}$, 80%RH or less					
Sampling rate		Approx. 2.5 times/sec. or more						

Item		PA10-5B	PA18-1.2B	PA18-2B	PA18-3B	PA18-5B	PA36-1.2B	PA36-2B	PA36-3B
FUNCTIONS									
OVP	ALARM LED goes on	Approx. 5 to 105%							
OHP	ALARM LED goes on	Output goes off when internal heat sink temperature reaches $105 \pm 5^{\circ}\text{C}$. (Only PA18-5B, PA36-3B are 110°C)							
Output switch	Remote on/off control	Output may be turned on or off with remote control switch on rear panel. (Front/rear control is selected with switch on front panel.)							
V/I check switch		Indicator indicates constant-voltage or constant-current set value when switch is turned on.							
Remote sensing		Enabled with (+S) and (-S) terminals on front panel. May correct up to 0.5 V, one way. ^{*5}							
Voltage monitor	Output voltage to monitor voltage ratio	Output voltage 0 to rated voltage/approx. 0 to 10 V output (Connector on rear panel)							
Current monitor	Output current to monitor voltage ratio	Output current 0 to rated current/approx. 0 to 10 V output (Connector on rear panel)							
Status signal	CV	Open collector output, Low in CV mode							
Parallel operation	CC	Open collector output, Low in CC mode							
	ALARM	Open collector output, Low in alarm mode							
	Master/slave system	Capable of one-control parallel operation. (Current error: $\pm 20\%$, up to 3 units. One-control is applicable to same models only.)							

Item		PA80-1B	PA120-0.6B	PA160-0.4B	PA250-0.25B	PA250-0.42B	PA350-0.2B	PA600-0.1B
FUNCTIONS								
OVP	ALARM LED goes on	Approx. 5 to 105%						
OHP	ALARM LED goes on	Output goes off when internal heat sink temperature reaches 105 ±5°C. (Only PA250-0.42B is 110°C)						
Output switch	Remote on/off control	Output may be turned on or off with remote control switch on rear panel. (Front/rear control is selected with switch on front panel.)						
V/I check switch		Indicator indicates constant-voltage or constant-current set value when switch is turned on.						
Voltage monitor	Output voltage to monitor voltage ratio	Output voltage 0 to rated voltage/approx. 0 to 10 V output (Connector on rear panel)						
Current monitor	Output current to monitor voltage ratio	Output current 0 to rated current/approx. 0 to 10 V output (Connector on rear panel)						
Status signal	CV	Open collector output, Low in CV mode						
	CC	Open collector output, Low in CC mode						
	ALARM	Open collector output, Low in ALARM mode						
Parallel operation	Master/slave system	Capable of one-control parallel operation. (Current error: ±20%, up to 3 units. One-control is applicable to same models only.)						

Item		PA10-5B	PA18-1.2B	PA18-2B	PA18-3B	PA18-5B	PA36-1.2B	PA36-2B	PA36-3B
OPERATING CONDITIONS									
Operating temperature/humidity range		0 to 40°C 10% to 80%RH							
Storage temperature/humidity range		-20 to 60°C 10% to 85%RH							
Cooling method		Natural convection							
Output polarity		Positive or negative grounding possible							
Ground proof voltage		±250VDC							
Insulation resistance	Between the chassis and input power supply terminal	DC500V 30MΩor more							
	Between the chassis and Output terminal	DC500V 20MΩor more							
Insulated resisting pressure	Between the chassis and input power supply terminal	AC1.5kV /1 minute							
POWER REQUIREMENTS									
Input Voltage, frequency		AC220V±10%、50/60Hz、1 φ							
Power consumption (VA)	At the time of AC rated input	Approx. 150VA	Approx. 60VA	Approx. 100VA	Approx. 140VA	Approx. 210VA	Approx. 105VA	Approx. 165VA	Approx. 220VA
Power consumption (W)	At the time of AC rated input	Approx. 120W	Approx. 50W	Approx. 75W	Approx. 110W	Approx. 165W	Approx. 80W	Approx. 130W	Approx. 170W
DIMENSIONS AND WEIGHT									
Dimensions(mm)		104 × 124 × 350	104 × 124 × 270		104 × 124 × 350		104 × 124 × 270	104 × 124 × 350	
Max. dimensions(mm)		106.2 × 144.3 × 368.3	106.2 × 144.3 × 288.3		106.2 × 144.3 × 368.3		106.2 × 144.3 × 288.3	106.2 × 144.3 × 368.3	
Weight		Approx. 6.6kg	Approx. 4.7kg	Approx. 4.7kg	Approx. 6.6kg	Approx. 6.6kg	Approx. 4.7kg	Approx. 6.6kg	Approx. 6.6kg
ACCESSORIES		One CD-ROM(instruction manual), One adjustment driver, One power cable(3P)							

Item		PA80-1B	PA120-0.6B	PA160-0.4B	PA250-0.25B	PA250-0.42B	PA350-0.2B	PA600-0.1B
OPERATING CONDITIONS								
Operating temperature/humidity range		0 to 40°C 10% to 80%RH						
Storage temperature/humidity range		-20 to 60°C 10% to 85%RH						
Cooling method		Natural convection						
Output polarity		Positive or negative grounding possible						
Ground proof voltage		±250VDC	±500VDC					±600VDC
Insulation resistance	Between the chassis and input power supply terminal	DC500V 30MΩor more						
	Between the chassis and Output terminal	DC500V 20MΩor more						DC600V 20MΩ or more
Insulated resisting pressure	Between the chassis and input power supply terminal	AC1.5kV /1 minute						
POWER REQUIREMENTS								
Input Voltage, frequency		AC220V±10%、50/60Hz、1 φ						
Power consumption (VA)	At the time of AC rated input	Approx. 170VA	Approx. 155VA	Approx. 150VA	Approx. 140VA	Approx. 220VA	Approx. 150VA	Approx. 130VA
Power consumption (W)	At the time of AC rated input	Approx. 140W	Approx. 115W	Approx. 100W	Approx. 105W	Approx. 150W	Approx. 110W	Approx. 100W
DIMENSIONS AND WEIGHT								
Dimensions(mm)		104 × 124 × 350						
Max. dimensions(mm)		106.2 × 144.3 × 368.3						
Weight		Approx. 6.6kg	Approx. 6.6kg	Approx. 6.6kg	Approx. 6.6kg	Approx. 6.6kg	Approx. 6.6kg	Approx. 6.6kg
ACCESSORIES		One CD-ROM(instruction manual), One adjustment driver, One power cable (3P)						

*1: By LCL (internal sensing) at the sensing terminal.

*2: Measurement is done by ground either positive or negative output.

*3: Responding time when output voltage returns to within 0.05%+10mV of the rating at ON.

*4: After warm up for approximately 30 minutes when the current is fed.

*5: When the power supply output is rated value or less.

3. INSTRUCTIONS ON USE

Be sure to read through the instructions shown below prior to using the PA-B series.



WARNING

3-1. Checking Source Voltage

- * Be sure to connect the PA-B series with a commercial power supply of the rated voltage.
- * The rated voltage is shown on the rating nameplate near the AC inlet on the rear panel.

3-2. Connection of Power Cable

- * Connect the power cable plug firmly into the AC outlet that carries the rated voltage.



CAUTION

3-3. Precautions for Connecting Output Terminals

- * The PA-B series is a floating type power supply unit. Normally, connect either the (+) or (-) output terminal on the front panel with the GND terminal (case GND) using a shorting bar.
- * The (+S) and (-S) terminals and switch on the front panel are used for remote sensing (PA10-5B, PA18-1.2B, PA18-2B, PA18-3B, PA18-5B, PA36-1.2B, PA36-2B and PA36-3B only). Normally, set the switch to the LCL position and connect nothing with the terminals. If the switch is set to the REM position, the voltage sensing circuit is disconnected internally, resulting in erroneous output voltage indication. For remote sensing connection, see section 5-2 "Remote Sensing" below.

3-4. Switches on Front Panel and Connection Terminals on Rear Panel

- * Make sure that the MASTER/SLAVE selector switch on the front panel is set to the M position.
- * Make sure that the OUTPUT SW F/R selector switch on the front panel is set to the F position.
- * Make sure that all remote selector switches on the front panel are set to the Off positions.
- * Connect nothing with the connection terminals on the rear panel unless the master/slave mode, remote control mode or the like is selected.

3-5. Digital Display

- * Digital display of the PA-B series is subject to 1-digit fluctuations, which depend on the performance of the A/D converter. Such fluctuations do not imply ripples or noises in output.
- * Display may become unstable if the available commercial power source contains much common mode noises or there is an intense noise source near the PA-B series. Be very careful.

3-6. Switching Points of Relay

- * The PA-B series switches the secondary taps of the internal transformer using a relay and changes the input voltage to the series regulator in order to reduce internal losses. It has three relay switching points, which vary with the input voltage.
- * If the input voltage varies when the preset output voltage is close to the relay switching point, the relay switches and a relay switching sound may be heard. (This implies no trouble.) Noises may be generated at the relay switching point when the output increases, depending on input voltage (low voltage) or load conditions.

3-7. Installation Environments

- * Use the PA-B series in the ambient temperature range from 0 to +40°C.
- * The PA-B series is a natural air cooling type power supply unit. Do not put any object on it, place it on a heat-generating object, or stack several PA-B units. Use the PA-B series in a place having as good ventilation as possible.
- * The heat sink built in the PA-B series may become hot during operation. Be very careful about ventilation. Do not place any object easily affected by heat near the PA-B series.
- * As the built-in heat sink overheats, the case of the PA-B series may become hot. If it is necessary to touch the case or move the PA-B series, turn off power and wait for a mean while (until the case cools down).



HOT BE CAREFUL

NEVER STACK!

HOT BE CAREFUL!

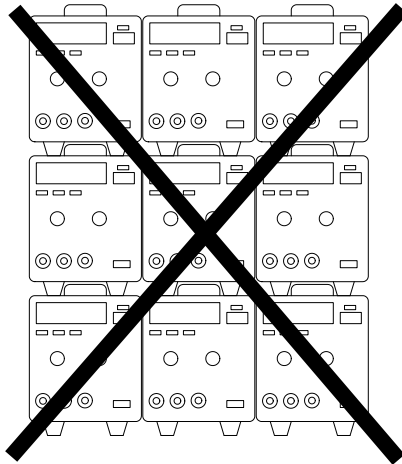

3-8. Rack Mounting



HOT BE CAREFUL

- * Contact the our distributor if you need the rack mounting kit.
- * The PA-B series is a natural air cooling type power supply unit. Proper heat radiation measures are needed when mounting it on a rack. Leave sufficient spaces above and below the unit mounted on a rack and take the proper heat radiation measures in order to prevent the temperature in the rack (ambient temperature) from exceeding the allowable temperature range. The OHP may work if the temperature exceeds the allowable temperature range.

3-9. Options

The guard cap and handle for the PA-B series are available by option. (The handle is mounted in the factory.) Contact our distributor for details.

* Guard cap (OP-20GC)

The guard cap is to be replaced with the knob to prevent the preset voltage or current from being changed by mistake.

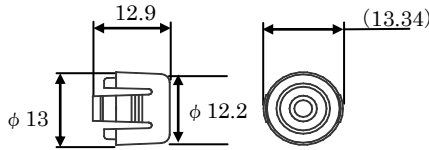

* Handle (XO-PA10, factory option)

The optional handle may be mounted to the PA18-1.2B, PA18-2B or PA36-1.2B only. The other models have handles as the standard features.

The handles enhance movement of the PA-B series.

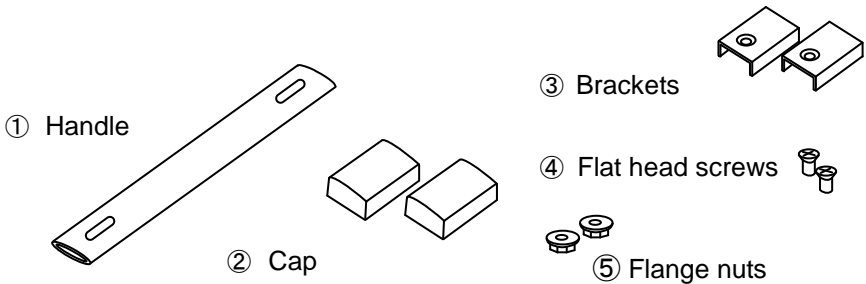

4. PANEL EXPLANATION

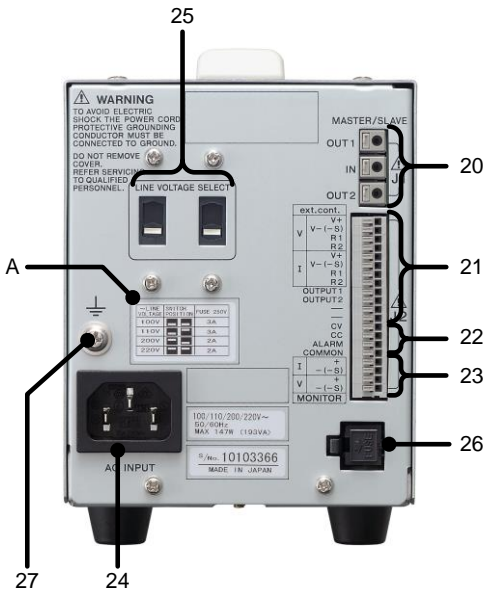
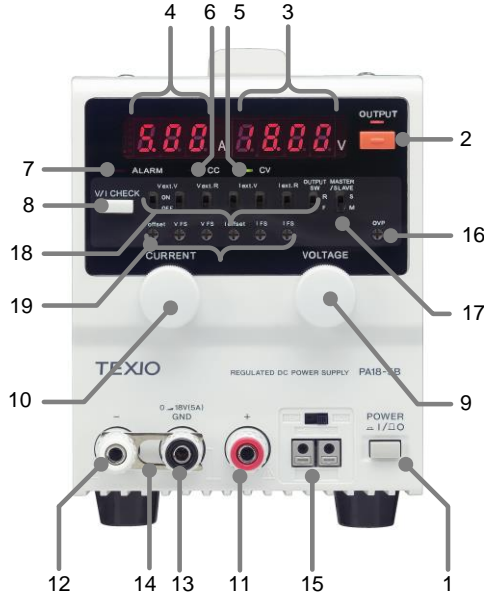

4-1. Front panel

1. POWER ON/OFF

The power switch of the PA-B series.

Set the switch to ON to turn on power. When power is turned on, the PA-B series runs.

2. OUTPUT key and OUTPUT LED (red)

The output On/Off switch of the PA-B series.

Press the OUTPUT key to turn on the output (and the OUTPUT LED goes on). The voltmeter and ammeter indicate the output values at that time.

When the OUTPUT key is pressed while the OUTPUT LED is lit, the OUTPUT LED goes out and the output is shut off.

NOTE 1: When the PA-B series is turned on, the OUTPUT LED and output are always off.

NOTE 2: When the OUTPUT F/R selector switch on the front panel is set to the R position, the OUTPUT key is disconnected and the output is set to the Off condition. If the PA-B series is turned on in this condition, the output is turned off.

3. Digital voltmeter (3 1/2-digit LEDs, red)

This voltmeter displays the output voltage or the set voltage (only when the V/I check key on the front panel is pressed).

4. Digital ammeter (3-digit LEDs, red)

This voltmeter displays the output current or the set current (only when the V/I check key on the front panel is pressed).

5. CV LED (green)

The constant-voltage mode indicator LED.

It is lit when the PA-B series is in the constant-voltage mode.

6. CC LED (red)

The constant-current mode indicator LED.

It is lit when the PA-B series is in the constant-current mode.

7. ALARM LED (red)

The alarm status indicator LED.

It is lit when the over-voltage or overheat protection circuit works and turns off the output. Press the POWER ON/OFF switch to turn off power once, eliminate the alarm cause, and turn on power again.

8. V/I CHECK key

This key is used to display the set voltage and set current.

The voltmeter displays the set voltage and the ammeter displays the set current while the key is held.

NOTE: When this key is pressed, the minimum digit of the voltmeter becomes 100 mV (or 10 mV on a model of 18 V rating).

9. VOLTAGE control

This control is used to set the voltage in constant-voltage operation. It varies and sets the limit value of the output voltage.

10. CURRENT control

This control is used to set the current in constant-current operation. It varies and sets the limit value of the output current.

11. Output terminal (+)

Positive (+) output is given through this terminal.

12. Output terminal (-)

Negative (-) output is given through this terminal.

13. GND terminal

This grounding terminal is connected with the frame. Connect a shorting bar between the GND terminal and (+) or (-) output terminal normally.

14. Shorting bar

The shorting bar is normally used to connect the GND terminal and (+) or (-) output terminal.

15. Remote sensing (PA10-5B, PA18-1.2B, PA18-2B, PA18-3B, PA18-5B, PA36-1.2B, PA36-2B and PA36-3B)

- REM/LCL selector switch

This switch is normally set to the LCL (internal sensing) position.

Set it to the REM position to execute remote sensing.

NOTE: Do not set this switch to the REM position unless the remote sensing function is used. Connect the sensing cable and load cable firmly to prevent them from being disconnected during sensing.

- +S terminal

The (+) output remote sensing terminal.

- -S terminal

The (-) output remote sensing terminal.

16. OVP control

This control is used to set the operating voltage of the OVP (over-voltage protection) circuit.

17. MASTER/SLAVE selector switch

This selector switch is used to carry out one-control parallel operation in the master/slave mode. Set it to the MASTER position normally. (For details, see section 5-11 "One-Control Parallel Operation" below.)

18. Rear panel control selector switch

This switch selects the constant-voltage, constant-current and output on/off remote controls. Set it to the OFF position normally. Operations on the front panel are enabled at this position. Remote controls are enabled at other positions. (For details, see section 5 "OPERATION PROCEDURES" below.)

19. Rear panel control volume

This volume is used for remote constant-voltage and constant-current controls.

(For details, see section 5 "OPERATION PROCEDURES" below.)

4-2. Rear panel

20. MASTER/SLAVE connection terminals

These terminals are used for one-control parallel operation in the master/slave mode. (For details, see section 5-11 "One-Control Parallel Operation" below.)

21. Rear panel remote control terminals

These terminals are used for constant-voltage, constant-current and output on/off remote controls. (For details, see section 5 "OPERATION PROCEDURES" below.)

22. Status signal output terminals

These terminals output the CV, CC and ALARM status signals. (For details, see section 5-8 "Status Signals" below.)

23. Voltage and current monitor signal output terminals

These terminals output the monitored voltage and current of the PA-B series in voltages. (For details, see section 5-9 "Monitoring Voltage and Current" below.)

24. AC inlet

The AC inlet connector of the PA-B series.

25. Input AC voltage selector switches

The 2 combination switches are located in the rear panel of the unit to select the input AC voltage. Set them as shown below to select AC 100V, 110V, 200V or 220V. However, it becomes a switch of AC100V, 115V, 200V, and 230V according to the model. Which voltage can be set is displayed in rear panel of the PA-B SERIES. (Please refer to the table for the A. Voltage setting table)

Use 115V for actual 120V AC operation.

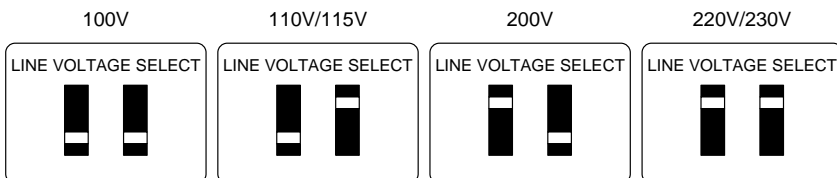

A. Voltage setting table

~LINE VOLTAGE	SWITCH POSITION	FUSE 250V
100V		000A
110V		000A
200V		000A
220V		000A

~LINE VOLTAGE	SWITCH POSITION	FUSE 250V
100V		000A
115V		000A
200V		000A
230V		000A



WARNING

NOTE: Be sure to disconnect the AC power cable before setting the input AC voltage.

Be sure to use the proper fuse as shown below.

	10-5	18-1.2	18-2	18-3	18-5	36-1.2	36-2	36-3
Fuse (time-lag) 100/200 VAC	3A/ 2A	1.6A/ 0.8A	2A/ 1.25A	3A/ 2A	5A/ 3A	2.5A/ 1.6A	3A/ 2A	5A/ 3A

	80-1	120-0.6	160-0.4	250-0.25	250-0.42	350-0.2	600-0.1
Fuse (time-lag) 100/200 VAC	3A/2A	3A/2A	3A/2A	3A/2A	4A/2.5A	3A/2A	3A/ 2A

26. Fuse holder

The AC input fuse is built in this holder.

27. Frame GND terminal screw

Use this screw to ground the frame of the PA-B series. Never use any other screw. Using any other screw may cause short-circuit inside the PA-B series, resulting in malfunctioning or breakdown.

5. OPERATION PROCEDURES

5-1. Independent Operation

- *Use the switches and terminals on the front panel to use the PA-B series alone.
- *Make sure that the switches on the front panel are set as shown below.

OUTPUT switch	: F (front) position
MASTER/SLAVE switch	: M (master) position
Various control ON/OFF switches	: OFF positions

5-2. Remote Sensing

- *When the PA-B series is connected with a load, the voltage at the load terminals is subject to load variance, which depends on the voltage drop caused by contact resistance of the output terminals or resistance of the load cable conductors.
Set the remote sensing selector switch on the front panel to the REM position, connect wires to the (+S) and (-S) remote sensing terminals and carry out remote sensing operation, if it is necessary to set the voltage at the load terminals finely.
- *The PA-B series compensates for voltage drop of the load cable up to 0.5 V (one way).
- *Do not set the selector switch to the REM position in normal operation without using the remote sensing function.



CAUTION

- This function is available in the PA10-5B, PA18-1.2B, PA18-2B, PA18-3B, PA18-5B, PA36-1.2B, PA36-2B and PA36-3B only.
- If no remote sensing cable is connected despite the fact that the remote sensing selector switch is set to the REM position, the output voltage may be too high and the load may be broken. Be sure to set the selector switch to the LCL position when remote sensing is not carried out.
- If the load is too apart from the PA-B series, inductance and capacitor of the load cable may cause oscillation. Connect an electrolytic capacitor of approximately 100 μF to the load terminals in such a case.

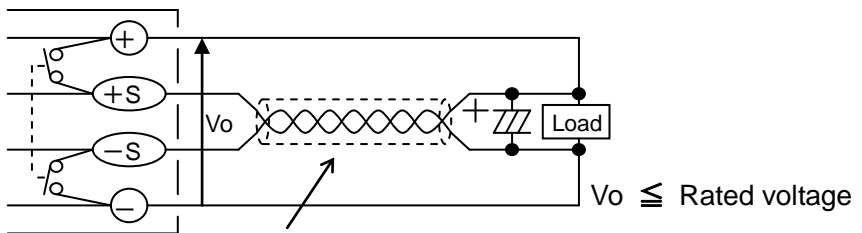

Use a shielded cable or twisted pair wires.

5-3. OVP

*The OVP protects the load from over-load. The ALARM LED goes on when the OVP circuit works. Shut off the POWER switch once and turn it on again to reset the alarm.

- 1) Turn the OVP control fully clockwise with the adjustment screwdriver supplied with the PA-B series.
- 2) Output the limit voltage for over-voltage protection. Turn the OVP control counterclockwise slowly with the adjustment screwdriver until the OVP circuit works.
- 3) Cut off output when the voltage between the output terminals of the PA-B series reaches the preset OVP value.

5-4. Remote Control Functions

1. Remote control application functions

The switches on the front panel are set as shown below by default.

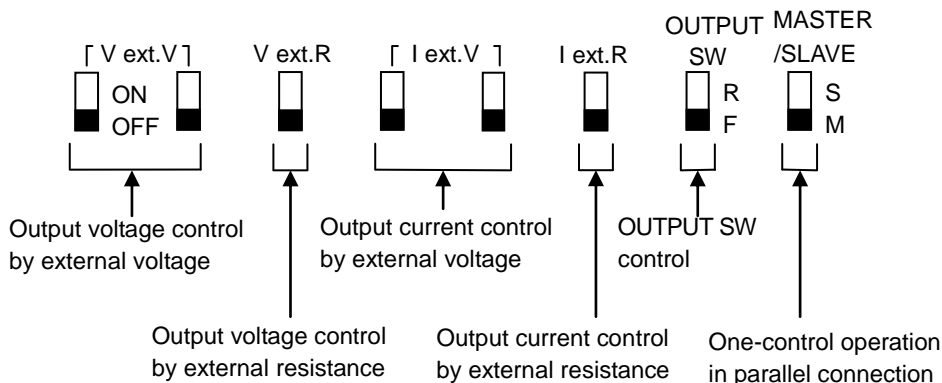

2. Remote control applications

Remote functions		MASTER /SLAVE	CV REMOTE voltage or resistance	CC REMOTE voltage or resistance	OUTPUT ON/OFF
Operation types					
Independent operation		Set to M	○	○	○
One-control parallel operation	MASTER	Set to M	○	○	○
	SLAVE	Set to S	×	×	○

○ : Remote control is available.

× : Remote control is not available.

3. Usage of connection terminals on rear panel

Follow the procedures shown below to connect the cables to the terminals on the right of the rear panel.

- 1) Apply a flathead screwdriver (thin screwdriver) to the slit on the right of the round (or square) hole for connecting a cable. Press it and insert the cable conductor into the round (or square) hole.
- 2) Disconnect the cable in the same manner. Press the slit with the screwdriver and pull out the cable.

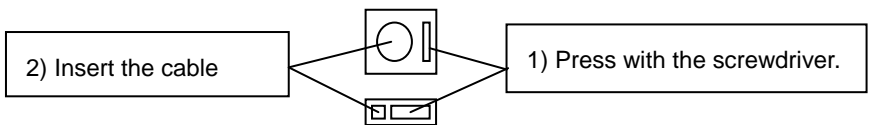

NOTE: Applicable wires: Solid wire: 0.4 to 1.0 mm dia. (AWG26 to 18)

Braided wire: 0.3 to 0.75 mm²

(AWG22 to 20)

Element wire: 0.18 mm dia. or more

Standard peel-off length: 10 mm (Solder the peeled conductors of a braided wire.)

4. GP-IB control

*It is possible to set the constant-voltage and constant-current values and control the OUTPUT switch of the PA-B series from a computer through the GP-IB bus (in conformity to IEEE-488-1978) if the optional GP-IB adapter GP-600B is used.

*A single GP-600B may control the following of each PA-B unit.

- Output voltage and current setting
- OUTPUT ON/OFF
- ALARM detection
- CV → CC, CC → CV mode interrupt

5-5. Output ON/OFF Remote Control

*It is possible to control output On/Off using external contact signals as shown below

- 1) Shut off the POWER switch.
- 2) Set the OUTPUT SW on the front panel to the R position with the attached adjustment screwdriver, and connect the cable to the terminals on the rear panel as shown below.

Front panel switch

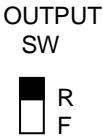

Terminals on rear panel

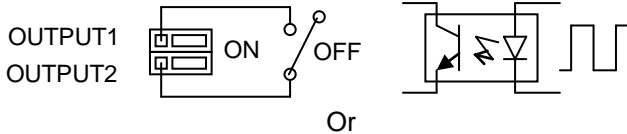

OUTPUT terminals	Output
Short	ON
Open	OFF

The OUTPUT key on the front panel is not active.

NOTES:

- Float the potential of the external contact signal from the potentials of the (+) and (-) outputs and GND (case GND). ON/OFF control using a photo-coupler is also enabled.
- 0.5 mA, 5 V max. output is applied to the external contacts.

※Selecting output ON and output fixing

- If the OUTPUT SW is set to the R position and the OUTPUT terminals on the rear panel are short-circuited, the output is turned on continuously.

In this condition, the output is turned on when the PA-B series is turned on.

5-6. Constant-Voltage Remote Control

1. Output voltage control using external voltage

*It is possible to control the output voltage using 0 to 10 V external voltage.

- 1) Shut off the POWER switch.
- 2) Set the offset and FS switches of "V ext. V" on the front panel to the ON positions with the attached screwdriver. Connect a cable to the terminals on the rear panel as shown below.

Front panel switches and controls

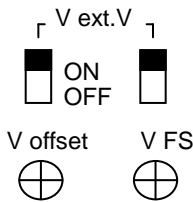

Terminals on rear panel

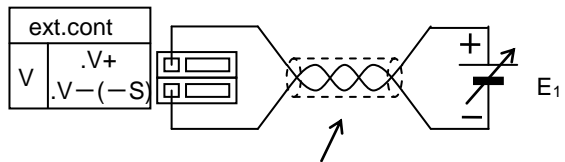

Use a shielded cable or twisted pair wires.

Relationship between output voltage (E_0) and external voltage (E_1)

$$E_0 \doteq \frac{E_{\max}}{10} \times E_1 \text{ [V]} \quad (0 \leq E_1 \leq 10\text{V})$$

E_0 : Output voltage

E_{\max} : Rated voltage

E_1 : External voltage

3) Adjustment procedures

- Apply 0.1 V between the "ext. cont. V" V+ terminal and "ext. cont. V" -(-S) terminal on the rear panel.
- Press the OUTPUT key to turn on power.
- Rotate the V offset control on the front panel with the attached adjustment screwdriver to adjust the output voltage to 1% of the rated voltage.
- Then, apply 10 V between the "ext. cont. V" V+ terminal and "ext. cont. V" -(-S) terminal on the rear panel.
- Rotate the V FS control on the front panel with the attached adjustment screwdriver to adjust the output voltage to 100% of the rated voltage.

NOTES:

- The negative (-) potential of the external voltage (E_1) represents the voltage at the (-) output terminal. The negative (-) potential of the internal control voltage also represents the voltage at the (-) output terminal. Therefore, be very careful when grounding the output.
- Ripples and noises contained in the external voltage are amplified and output. Thus, use external voltage with less ripples and noises.
- The input impedance (Z_{in}) of E_1 is approximately 10 k Ω .
- Supply E_1 using a two-core shielded cable or stranded (+) and (-) twist pair wires.

2. Output voltage control using external resistance

*It is possible to output voltage in proportion to resistance between 0 to 10 k Ω .

- 1) Shut off the POWER switch.
- 2) Set the V ext. R switch on the front panel to the ON position with the attached screwdriver. Then, connect a cable to the terminals on the rear panel as shown below.

Front panel switch and control

Terminals on rear panel

V ext.R

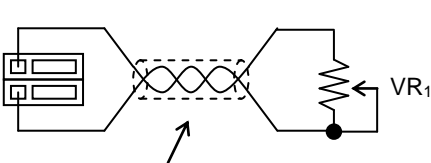
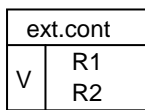

Use a shielded cable or twisted pair wires.

Relationship between output voltage (E_0) and external resistance (VR_1)

$$E_0 \doteq \frac{E_{\max}}{10}$$

$$\times VR_1 \text{ [k}\Omega\text{]} \quad (VR_1 \leq 10\text{k}\Omega)$$

E_0 : Output voltage

E_{\max} : Rated voltage

VR_1 : External resistance

3) Adjustment procedures

- Connect an external resistor VR_1 between the "V ext. cont." R1 terminal and "V ext. cont." R2 terminal on the rear panel.
- Set the VR_1 to 10 k Ω .
- Press the OUTPUT key to turn on power.
- Rotate the V FS control on the front panel with the attached adjustment screwdriver to adjust the output voltage to the rated voltage.

Front panel

V FS



NOTE:

- The potential at the terminals of the external resistor (VR_1) should be floated from the (+) and (-) output and GND potentials.
- As VR_1 , use a variable resistor which is free from aged deterioration and noises and has a temperature coefficient of approximately 100 ppm/ $^{\circ}$ C and capacity of 1/2 W or more.
- Connect VR_1 with a two-core shielded cable or stranded (+) and (-) twist pair wires.



CAUTION

- If VR_1 is opened, over-voltage is output.
- When changing the resistance using a switch or the like, it should be a short circuit type switch that does not make the circuit open.
- Do not set the V ext. R switch to the ON position in the condition where the output is on. Otherwise, voltage exceeding the maximum rating is applied to the output, resulting in breakage of the load.

5-7. Constant-Current Remote Control

1. Output current control using external voltage

*It is possible to control the output current using 0 to 10 V external voltage.

- 1) Shut off the POWER switch.
- 2) Set the offset and FS switches of "I ext. V" on the front panel to the ON positions with the attached screwdriver. Connect a cable to the terminals on the rear panel as shown below.

Front panel switches and Terminals on rear panel

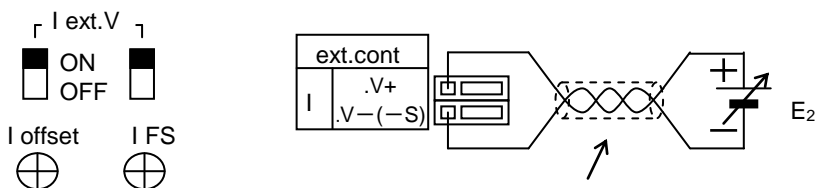

Use a shielded cable or twisted pair wires.

Relationship between output current (I_0) and external voltage (E_2)

$$I_0 \doteq \frac{I_{\max}}{10} \times E_2 \text{ [V]} \quad (0 \leq E_2 \leq 10\text{V})$$

I_0 : Output current

I_{\max} : Rated current

E_2 : External voltage

3) Adjustment procedures

- Apply 0.1 V between the "ext. cont. I" V+ terminal and "ext. cont. I" V- (-S) terminal on the rear panel.
- Press the OUTPUT key to turn on power.
- Rotate the I offset control on the front panel with the attached adjustment screwdriver to adjust the output current to 1% of the rated current.
- Then, apply 10 V between the "ext. cont. I" V+ terminal and "ext. cont. I" V- (-S) terminal on the rear panel.
- Rotate the I FS control on the front panel with the attached adjustment screwdriver to adjust the output current to 100% of the rated current.

NOTES:

- The negative (-) potential of the external voltage (E_2) represents the voltage at the (-) output terminal. Therefore, be very careful when grounding the output.
- Ripples and noises contained in the external voltage are amplified and output. Thus, use external voltage with less ripples and noises.
- The input impedance (Z_{in}) of E_2 is approximately 10 k Ω .
- Supply E_2 using a two-core shielded cable or stranded (+) and (-) twist pair wires.

2. Output current control using external resistance

*It is possible to output current in proportion to resistance between 0 to 10 k Ω .

- 1) Shut off the POWER switch.
- 2) Set the I ext. R switch on the front panel to the ON position with the attached screwdriver. Then, connect a cable to the terminals on the rear panel as shown below.

Front panel switch and control

Terminals on rear panel

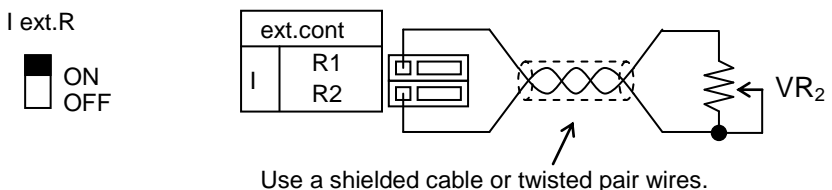

Relationship between output current (I_0) and external resistance (VR_2)

$$I_0 \doteq \frac{I_{max}}{10} \times VR_2 \text{ [k}\Omega\text{]} \quad (VR_2 \leq 10\text{k}\Omega)$$

I_0 : Output current
 I_{max} : Rated current
 VR_2 : External resistance

3) Adjustment procedures

- Connect an external resistor VR_2 between the "I ext. cont." R1 terminal and "I ext. cont." R2 terminal on the rear panel.
- Set the VR_2 to 10 k Ω .
- Press the OUTPUT key to turn on power.
- Rotate the I FS control on the front panel with the attached adjustment screwdriver to adjust the output current to the rated current.

Front panel

I FS



NOTES:

- The potential at the terminals of the external resistor (VR_2) should be floated from the (+) and (-) output and GND potentials.
- As VR_2 , use a variable resistor which is free from aged deterioration and noises and has a temperature coefficient of approximately 100 ppm/ $^{\circ}$ C and capacity of 1/2 W or more.
- Connect VR_2 with a two-core shielded cable or stranded (+) and (-) twist pair wires.



CAUTION

- If VR_2 is opened, over-current is output and the PA-B series may be damaged.
- When changing the resistance using a switch or the like, it should be a short circuit type switch that does not make the circuit open.
- Do not set the I ext. R switch to the ON position in the condition where the output is on. Otherwise, current exceeding the maximum rating is output, resulting in breakage of the load.

5-8. Status Signals

1. CV operation status output signal

This signal is active while the PA-B series is running in the CV (constant-voltage) mode.

2. CC operation status output signal

This signal is active while the PA-B series is running in the CC (constant-current) mode.

3. ALARM status output signal

This signal goes active when the PA-B series enters an alarm status. It enters the alarm status and turns off output if the OVP or OHP circuit works.

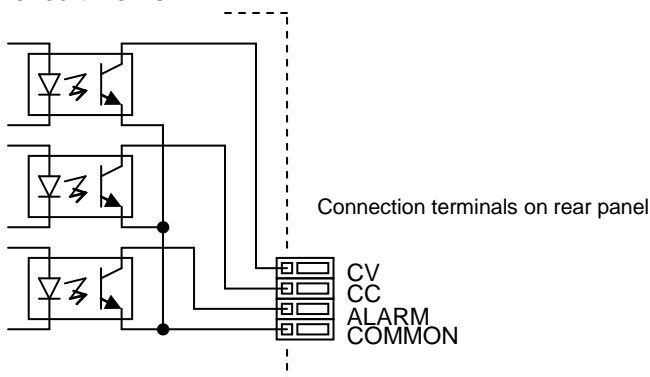

NOTE: The status signal output terminals shown above are connected with the transistors at the light receiving elements of the photo-couplers (TOSHIBA TLP521-1) inside the PA-B series. See the photo-coupler ratings shown below and use these signals properly.

※ Maximum rating of photo-coupler TLP521-1

Item	Symbol	Max. rating	Unit	
Output	Collector-emitter voltage	V_{CEO}	55	V
	Emitter-collector voltage	V_{ECO}	7	V
	Collector current	I_C	50	mA
	Collector loss	P_C	150	mW
Total allowable loss	P_T	250	mW	
Dielectric strength voltage	BV_S	2500	Vrms	

5-9. Monitoring Voltage and Current

*It is possible to monitor the output voltage and current of the PA-B series in terms of voltages.

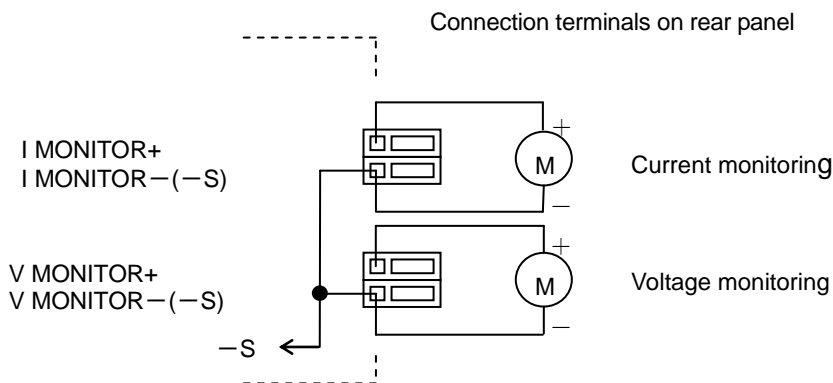

- 1) Shut off the POWER switch.
- 2) Connect a voltage monitoring meter between the V MONITOR + terminal and V MONITOR -(-S) terminal on the rear panel. Connect a current monitor meter between the I MONITOR + terminal and I MONITOR - (-S) terminal.
- 3) Throw the POWER switch to turn on power.
- 4) When the output voltage is in the range between 0 V and the rated voltage, voltage between 0 and approximately 10 V is output through the V MONITOR + terminal and V MONITOR -(-S) terminal.
- 5) When the output current is in the range between 0 A and the rated current, voltage between 0 and approximately 10 V is output through the I MONITOR + terminal and I MONITOR -(-S) terminal.

NOTE: The V MONITOR - (-S) and I MONITOR - (-S) terminals are connected together internally. The -S terminal is connected with the frame GND through the shorting bar. Use the monitor meters in the floated condition to avoid accidents or malfunctioning. These monitor terminals may not be used to observe waveforms.

5-10. Series and Parallel Connections

1. Series connection

*It is possible to increase the output voltage by connecting two or more PA-B power supply units.

- In the connection example shown below, the total output voltage is the sum of the output voltage of each PA-B power supply unit. (Left figure)

- In the connection example shown below, the positive and negative powers are output. (Right figure)

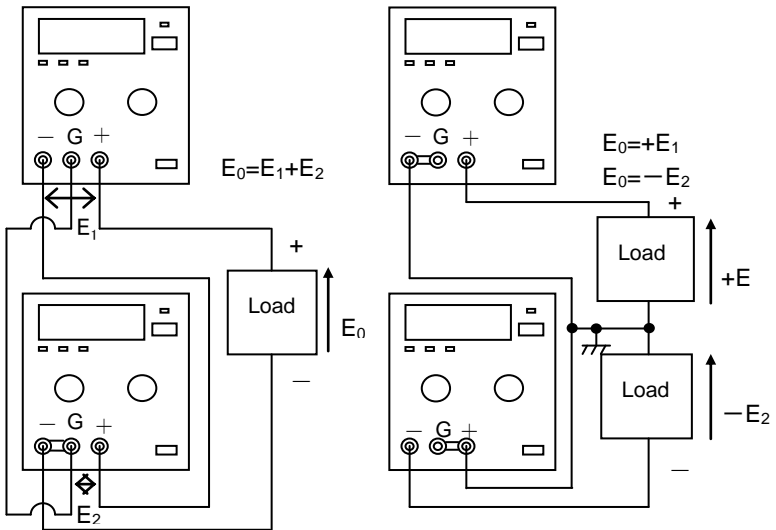

NOTE 1: In series connection, the voltage at the output terminals must not exceed the withstand grounding voltage (between the output terminals and frame GND). Be very careful.

NOTE 2: Connect the GND terminals of the PA-B power supply units together with an intended potential to eliminate the potential among the frame grounds of the power supply units.

(The above drawing shows the negative (-) grounding.)

NOTE 3: Do not connect the PA350-0.2B and PA600-0.1B in series.

NOTE 4: Be sure to float the control input of each power supply unit when using the external control function.

2. Parallel connection

*It is possible to increase the output current by connecting two or more PA-B power supply units in parallel.

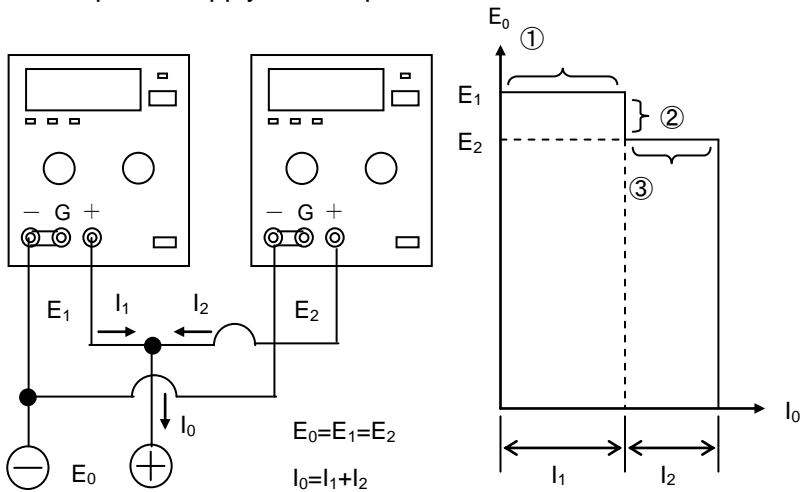

*Constant-voltage (CV) application

Make the output voltage of each power supply unit equal.

Difference in the output voltages (like $E_1 > E_2$) will result in fluctuations for the load.

- ① Current is supplied from E_1 first.
- ② When the current enters the constant-current (CC) zone and the output voltage lowers,
- ③ E_2 begins to supply current then.

*Constant-current (CC) application

Make sure that the CC LED on each power supply unit is lit.

The total output current is the sum of the output current of each power supply unit.

NOTE 1: Do not apply any voltage exceeding the rated voltage to the output of each power supply unit.

NOTE 2: Current of several mA flows back to the power supply unit with lower output voltage.

5-11. One-Control Parallel Operation

*It is possible to control units connected in parallel (i.e., two slave units) and increase their output capacity from one unit (master unit).

*The total output current capacity is the sum of the output current of each slave unit.

- 1) Turn off power of all master and slave units.
- 2) Set the MASTER/SLAVE switches on the front panels of all slave units to the S position.
- 3) Connect the parallel operation terminals (IN/OUT1/OUT2) on the rear panels of the master and slave units as shown in the drawing.
- 4) Connect the output terminals of the power supply units with the load using cables of the same length as shown in the connection diagram.
- 5) Rotate the voltage control of all slave units fully clockwise.
- 6) Throw the POWER and OUTPUT switches of the slave units.
- 7) Throw the POWER and OUTPUT switches of the master unit.
The output voltage and current may be set freely with the voltage and current controls of the master unit.

NOTE 1: -The CV or CC LED of the master unit shows the output mode.
- On the slave units, the CC LEDs are always lit.

NOTE 2:-Connect the GND terminal with the (+) or (-) terminal. This commonly applies to the master and slave units. (The output connection diagram below shows the (-) grounding connection.)

NOTE 3: -In parallel operation, it may sometimes be impossible to vary the output voltage on the master unit when the output reaches 0 A. Use the master unit so that several % or more of the rated current always flows.

NOTE 4:-Set the controls of the slave units to the maximum positions in parallel operation.

- * Control the master unit only in remote control.
Read section 5-4 "Remote Control Functions" above.

Setting of Front Panel Switches and Connection of Rear Panel Terminals for Parallel Operation

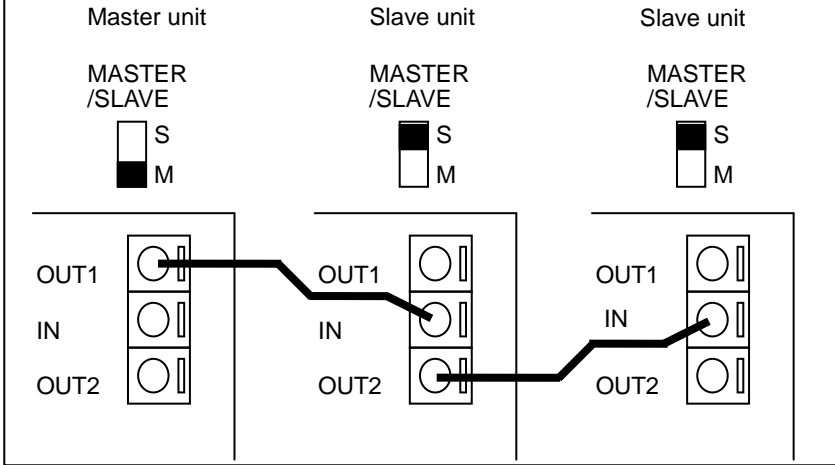

Output Connection Diagram for Parallel Operation

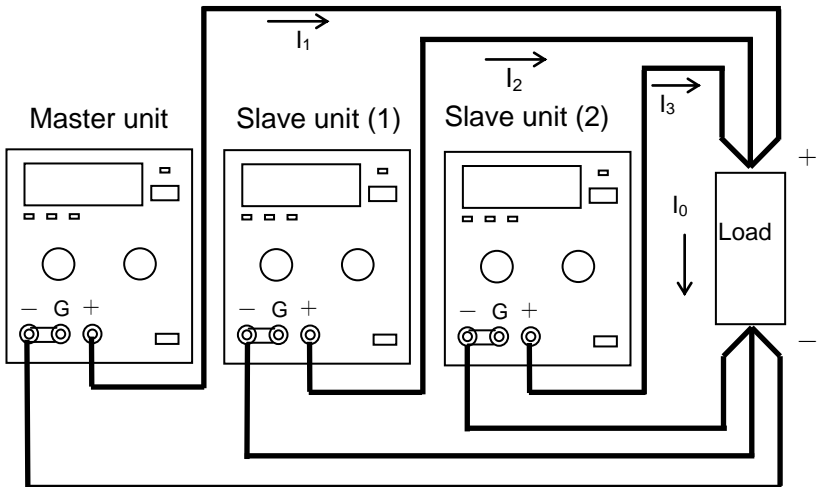

NOTE: $I_0 = I_1 + I_2 + I_3$

Set the voltage controls of all slave units to the maximum position.

The master unit runs in the CV mode. The slave units run in the CC mode.

5-12. Recharging Battery

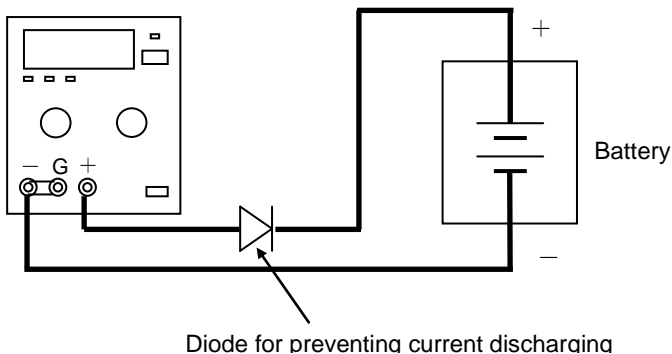

*A capacitor of several μ to dozens of μ is connected to the output of the PA-B series. The PA-B series incorporates a circuit for discharging electric charges from the capacitor when power is turned off. Be sure to connect a diode for preventing current discharging as shown above when using the PA-B series for recharging a battery.

NOTE: Use a diode having enough capacity to withstand the rated current of the PA-B series.

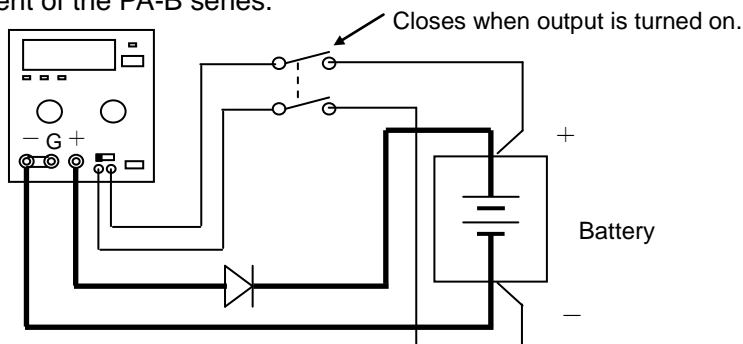

*Be sure to connect a relay between the +S and -S wires in series as shown above when recharging a battery using the voltage remote sensing function. The relay must close when the output is turned on and open when the output is turned off. Discharged current also flows through the +S and -S wires.

6. TROUBLES AND PHENOMENA

Phenomenon	Check point	Trouble cause
Power is not turned on even if the POWER switch is thrown. (LED on the front panel does not go on.)	Poor contact or breakage of the power cable Blowout of the fuse	*Poor contact or breakage of the power cable Blowout of the fuse *POWER switch is defective. *Too high AC voltage is input.
No voltage is output.	Voltmeter does not shake.	*Circuit is defective.
No current is output.	Ammeter does not shake.	*Circuit is defective.
Excessive output is yielded.	Output voltage or current does not lower.	*Power transistors are defective or uncontrollable. *Circuit is defective.
Output is unstable.	Difference of the input Voltage Oscillation Intense magnetic or electric field near the PA-B unit	*Input voltage is out of the rating range. *Oscillation due to a special load. *Move the PA-B unit from the oscillation source.

If the trouble is caused by blowout of the input fuse, replace it with a fuse of the specified rating. Disconnect the power cable before replacing the fuse.

If the trouble seems to be caused by defects of the internal circuit, contact our distributor.



WARNING

Never remove the case. Entrust our distributor with repair services requiring removal of the case.

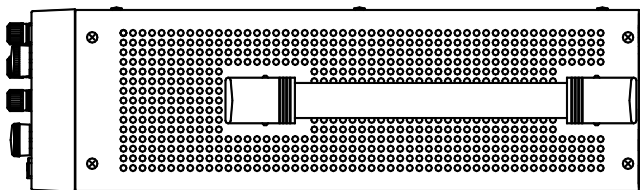
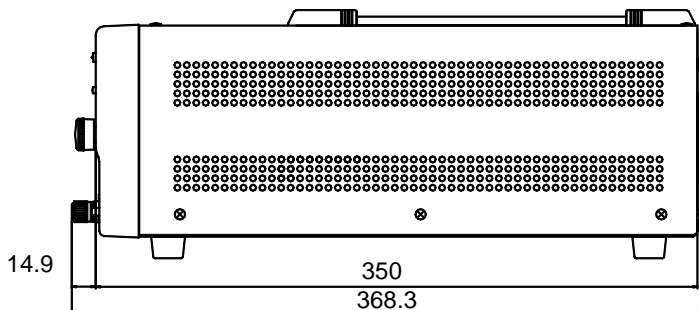

Long type

(PA10-5B、PA18-3B,5B、PA36-2B,3B、PA80-1B~PA600-0.1B)



TEXIO TECHNOLOGY CORPORATION

7F Towa Fudosan Shin Yokohama Bldg.

2-18-13, Shin Yokohama, Kohoku-ku, Yokohama, Kanagawa, 222-0033 Japan

<http://www.texio.co.jp/>
